

RESEARCH AVIATION FACILITY

BULLETIN 22

National Center for Atmospheric Research
P.O. Box 3000 • Boulder, CO 80507-3000
Telephone: (303) 497-1036 • Telex: 258889 (NCAR.RAF)

10/87

AIRBORNE HUMIDITY MEASUREMENTS

The NCAR Research Aviation Facility (RAF) currently provides two types of instruments for the airborne measurement of atmospheric humidity. The standard humidity measurement, which is provided for all projects, is performed using the chilled mirror technique for measuring dew point temperature. This system combines good accuracy and a response adequate for mean humidity measurements with the ability to provide continuous readings over a wide range of environmental conditions. Projects requiring fast response, high resolution flux measurements will need to add a second instrument which uses Lyman-alpha absorption to measure the moisture content directly. Both instruments have specific performance features that govern their use in different applications. This bulletin provides a detailed description of each unit along with a discussion of their performance characteristics.

I. STANDARD MEASUREMENT SYSTEM — EG&G MODEL 137 HYGROMETER

A. Principle of Operation

The determination of dew point temperature by the chilled mirror technique has evolved into a system for routine operational aircraft use. The EG&G Model 137 hygrometer was chosen as the standard humidity measuring system at RAF because it represents one of the best and most reliable applications of this technology. With this type of system, the temperature of a reflecting surface is lowered until water vapor saturation is reached and a deposit of water (or ice) is formed. The saturated vapor pressure at the deposit temperature is equal to the partial pressure of the water vapor in the air passing over the deposit. This technique represents a fundamental measurement of the dew point temperature, which corresponds to the temperature at which condensation occurs. In temperature regimes falling below the standard freezing point (0°C), the measured temperature actually represents the frost point. These values are converted back into equivalent dew point temperatures during data processing before any additional moisture calculations are performed.

The EG&G Model 137 employs Peltier thermoelectric junctions to control the temperature of its sensing mirror. Figure 1 illustrates the general design of this type of

hygrometer in block form. The sensing mirror is in close thermal contact but electrically isolated from the Peltier thermoelectric junctions used for cooling and heating. The junctions are used to pump heat to and from the mirror and thus change the module (mirror and junction) temperature. As the mirror temperature reaches the dew (or frost) point, condensate forms on the mirror surface causing the reflective characteristics of the mirror to change. This change is detected by photo-resistors in the optical sensing bridge and converted to an electrical signal driving an amplifier whose output signal is fed back into the cooler and thus stabilizes the mirror temperature at a particular dew or frost layer thickness. The mirror temperature, which is measured with a platinum resistance thermometer, is taken to be the dew point temperature.

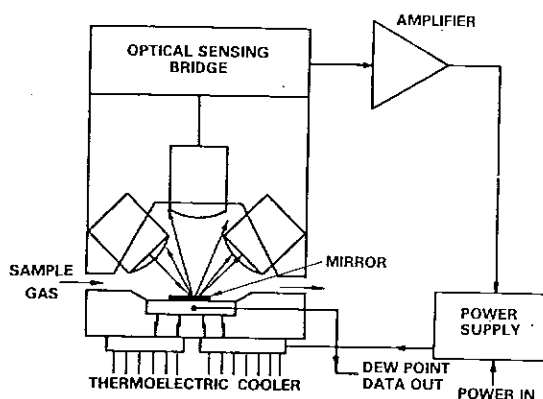

Figure 1. Block diagram of thermoelectric dew/frost point hygrometer.

B. System Design

The EG&G hardware is divided into two primary components: an externally mounted sensing head assembly and an electrical control unit.

- **HEAD:** The sensing head, consisting of the air intake, thermoelectric cooling module and optical sensing bridge, is mounted on a vertical section of the fuselage. This position, near the fuselage static pressure ports, avoids the pressure fluctuations resulting from changes in the aircraft's flight attitude while exposing the sample intake to relatively undisturbed ambient conditions. Flow through the sample chamber results from a pressure differential induced by the high speed airflow around the aerodynamically shaped head assembly. The head (see Figure 2) is oriented in such a way that the sample flow rate is maintained at approximately 1.5 liters/min.
- **CONTROL UNIT:** The electrical control unit, consisting of the amplifier, power supply, and electrical balance adjustment, is mounted within the aircraft cabin. The

unit allows for a real-time status check of the instrument's in-flight performance along with the ability to correct obvious problems in the response of the sensing head.

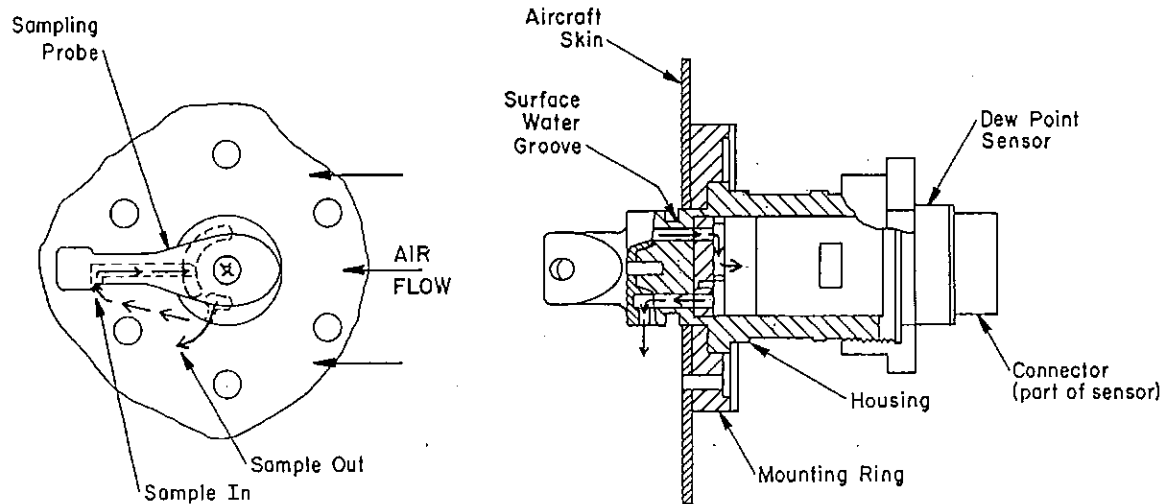

Figure 2. Sensor head design for EG&G dew point unit.

C. Calibration

The manufacturer installs platinum thermometers in the mirror assemblies. The factory level calibration then consists of checking each system with a standard hygrometer calibration unit which is traceable to the gravimetric humidity standard of the National Bureau of Standards. RAF uses this calibration ($^{\circ}\text{C}/\text{ohm}$) to generate a system calibration based on simulated resistance changes in the sensing circuit. Calibrations are performed both before and after each project and are normally completed within a few days of the operations period. In addition, a second complete and collocated EG&G system is always included in every instrument package for a comparative analysis.

D. Performance Characteristics

- **RANGE:** The 137 hygrometer system is designed to measure dew/frost points between -50°C and $+50^{\circ}\text{C}$. The lowest dew point which can be measured is dictated by the ambient temperature at which the junction is operating. As a general rule, the unit has difficulty maintaining dew point depressions in excess of 20 to 25°C ($\text{RH} < 10\%$).
- **ACCURACY:** At dew point temperatures above freezing (0°C) the accuracy of the unit will be $\pm 0.5^{\circ}\text{C}$.

At temperatures below freezing, where the condensate takes the form of frost, accuracy will be reduced to $\pm 1.0^{\circ}\text{C}$.

- **RESPONSE:** At small depressions the sensor mirror can typically cool or heat at 2° C/s. Response to changes over a frost surface, ambient temperatures below 0° C, will be slightly slower.

II. SUPPLEMENTAL FAST RESPONSE SYSTEM — NCAR/RAF LYMAN-ALPHA HYGROMETER

A. Principle of Operation

The Lyman-alpha hygrometer was designed and built by NCAR to provide fast response, high resolution measurements of humidity. Lyman-alpha radiation is emitted by hydrogen atoms at a narrow line in the far ultraviolet portion of the spectrum 121.56 nanometers. It is produced by an electrical discharge in hydrogen. As the Lyman-alpha radiation passes across the sensing chamber, it is partially absorbed by atmospheric water vapor. An increase in absolute humidity results in increased absorption by the water vapor thus decreasing the detected signal. This signal change follows Beer's law such that:

$$I = I_o \exp(-kx\rho/\rho_o)$$

where I = received signal; x = path length; I_o = transmitted signal; k = absorption coefficient; ρ = concentration of water in the sensing volume; and ρ_o = concentration of water vapor at standard temperature and pressure.

With I_o , k , x , and ρ_o being intrinsic properties of the system, the received signal provides a direct measure of water content within the sample volume.

In actual practice, liquid water, oxygen, and ozone will also absorb significant amounts of Lyman-alpha radiation and thus attenuate the received signal. Under the proper operating conditions, however, oxygen makes only a weak to moderate contribution to total absorption and its effects can be removed using measurements of temperature and pressure to calculate the fractional oxygen density. Ozone absorption does represent a true interferent but only becomes significant at extremely high altitudes (stratosphere) where the natural ozone concentrations routinely reach significant levels. Liquid water on the other hand, is often encountered at operational altitudes and its presence in the sampling chamber can result in a film of water forming on the window surfaces. Measurements made under these conditions are highly suspect and represent the basic limitation of this technique.

In its current configuration the Lyman-alpha hygrometer is not an absolute, stand-alone system for airborne use (Friehe and Grossman, 1986; Spyers-Duran and Schanot, 1987). There is some gain drift inherent in the system which results inflight-to-flight and in-flight deviations of the mean humidity baseline derived from the Lyman-alpha measurements. In order to obtain a true absolute humidity, it is necessary to process the Lyman-alpha data in conjunction with the mean humidity data available from the more stable EG&G units. This processing technique loosely couples the two systems, removing baseline drift while not affecting the high-rate fluctuations. Although the

coupling process continues to be effective through the full range of measurements, the drift in the instrument's response deteriorates at the higher altitudes. The baseline drift adjustments soon approach the absolute value of the mean ambient humidity and therefore make the Lyman-alpha of limited use for low humidity, high altitude applications (Schanot, 1987). Low level boundary layer applications provide much better data, with typical drift errors limited to approximately $\pm 10\%$.

B. System Design

The primary components in the Lyman-alpha hygrometer are: the Lyman-alpha source; a detector; a low drift operational amplifier; and the supporting circuitry.

- **SOURCE:** A DC-excited, cold-cathode glow discharge lamp is used in the Lyman-alpha source because it is simple and easy to drive. The lamp is sealed within the body of the source which contains hydrogen gas under pressure. A glow discharge from the lamp excites the hydrogen within the source chamber which in turn generates light at the Lyman-alpha wave length. Improved spectral purity has been achieved by sealing UH-3 into the source body as a hydrogen source. The partially hydrogenated uranium is able to reversibly bind and release hydrogen in order to replenish losses due to chemical reaction with various lamp materials. By maintaining the chamber at a constant temperature, the U2-UH-3 sealed inside provides the desired amount of hydrogen in the source. The Lyman-alpha light leaves the source through a magnesium fluoride window facing the sampling volume. Magnesium fluoride is required since most other materials are opaque in the far UV range.
- **DETECTOR:** Detection of the incoming radiation is accomplished with a nitric oxide ion chamber. A photoionization chamber is a simple device containing an ionizing gas and two electrodes. Incoming radiation ionizes the gas (nitric oxide in this application), and an electric field maintained between the electrodes induces electron and ion drift. The resultant current is proportional to the incident light intensity. Radiation enters the detector through another magnesium fluoride window aligned with the source across the sampling volume. The combination of the magnesium fluoride windows and nitric oxide as the ionization medium limit the response of the detector to incident wave lengths between 132 and 115 nm. This effectively filters almost everything except the Lyman-alpha line.

For aircraft use it is essential that the housing containing the source-detector mount allow sampling of air well away from the aircraft boundary layer. The two types of housing in current use are presented in Figure 4. Both housings maintain a fixed path length between the source and detector with the sampling volume positioned approximately 14 cm above the aircraft skin. The housing in Figure 4a has been in use for several years with good results but fails to prevent liquid water from reaching the sample volume. The housing in Figure 4b is of recent design and is an attempt to minimize the effects of liquid water on the measuring system. Either housing may be chosen by the user, depending upon the type of experiment being conducted.

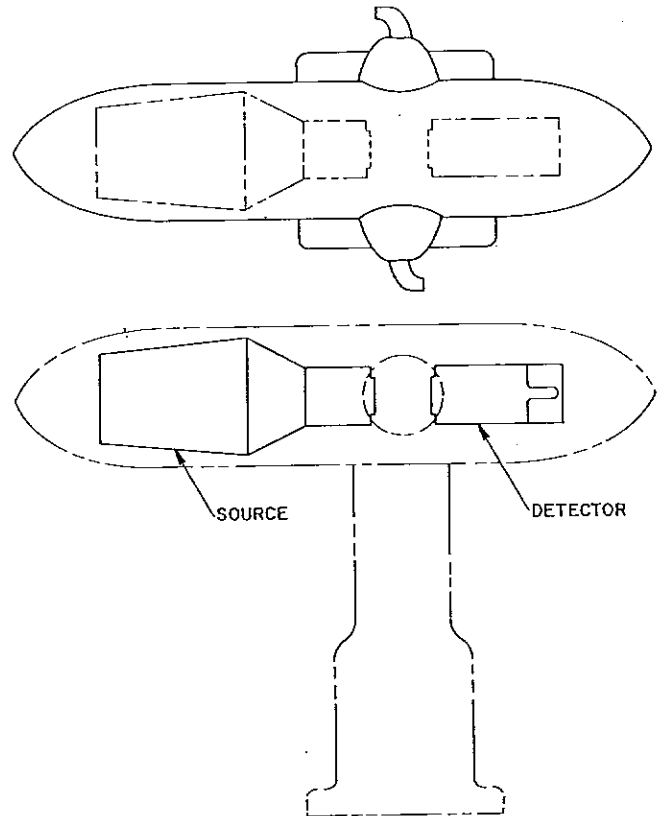
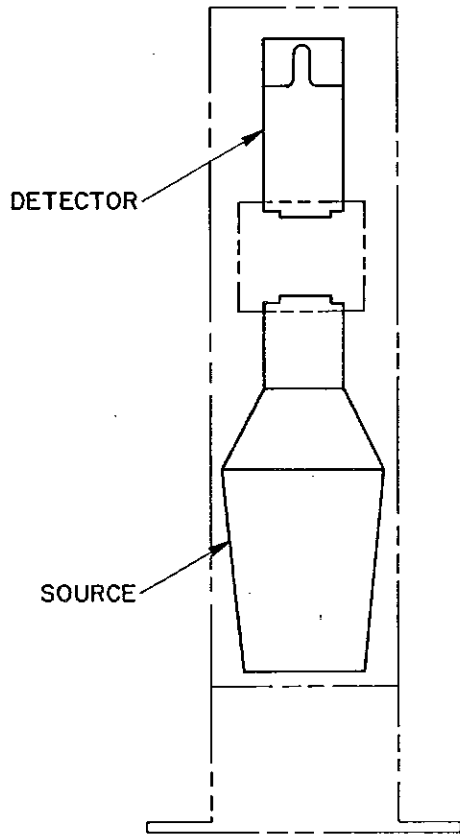

4a. Lyman-alpha upright sensing head.

4b. Lyman-alpha cross-head sensing head.

C. Calibration

Due to the similarity from source to source, the calibration coefficients will only vary by about 6 percent on average. Sensor response is determined on a pre and post project basis using gases with known absorption characteristics at the Lyman-alpha wave length. Response corrections are applied through the use of an equivalent sampling path length which covers collimation effects as well as source or detector changes. Any minor adjustments are made through the loose couple data processing procedure that references the Lyman-alpha response against the EG&G Model 137 units.

D. Performance Characteristics

The instrument can function adequately between 0.5 to 25 g/m³, absolute humidity. Specific operating ranges will vary with path length.

- **ACCURACY:** The baseline for the instrument tends to drift during flight thus reducing its accuracy in terms of true dew point values or absolute humidity. With periodic adjustments to the baseline by comparison with the EG&G values, the accuracy can be maintained at $\pm 4\%$ for relative humidity and $\pm 0.6^\circ\text{C}$ for dew point values.
- **RESPONSE:** The response of the instrument is unimpaired by temperature or humidity extremes and measures 2 milliseconds, which is much faster than the normal data system sampling rate.

References

- Friehe, C. A., R. L. Grossman and Y. Pann., 1986: Calibration of an airborne Lyman-alpha hygrometer and measurement of water vapor flux using thermoelectric hygrometer. *J. Atmos. Oceanic Tech.*, **3**, 299-304.
- Schanot, A. J., P. Spyers-Duran, 1987: Airborne Intercomparison of Three Hygrometers. *Preprints, Sixth Symposium Meteorological Observations and Instrumentation*, New Orleans, LA., American Meteorological Society, 209-212.
- Schanot, A. J., 1987: Evaluation of the Uses and Limitations of Lyman-alpha Hygrometer as an Operational Airborne Humidity Sensor. *Preprints, Sixth Symposium Meteorological Observations and Instrumentation*, New Orleans, LA., American Meteorological Society, 257-260.

