

The HALO Microwave Temperature Profiler (MTP) Design Package

MJ Mahoney and Richard Denning

Jet Propulsion Laboratory
California Institute of Technology
Pasadena, CA 91109-8099

MJM: (818)-354-5584

RFD: (818)-354-2795

FAX: (818)-393-0025

Email: Michael.J.Mahoney@jpl.nasa.gov
Richard.F.Denning@jpl.nasa.gov

Version: 1.01

Date: October 12, 2010

HALO MTP Design Package
JPL/Caltech PROPRIETARY —Not for Public Release or Redistribution

Preface

This is a living document and therefore under constant revision. Its purpose is to document everything that we know about the HALO Microwave Temperature Profiler (MTP) so as to facilitate certification of the instrument.

Revision History

Version	Date	Comment
1.00	Aug 05, 2010	Initial release
1.01	Oct 12, 2010	Additions to meet DLR certification needs

Jet Propulsion Laboratory
California Institute of Technology
4800 Oak Grove Drive
Pasadena, California 91109-8099
(818)-354-4321



October 12, 2010

To Whom It May Concern

Certificate of Conformity

We the undersigned, Michael J. Mahoney and Richard F. Denning, confirm that the HALO Microwave Temperature Profiler (MTP) built by JPL and delivered to DLR in October 2010 uses parts and materials as specified in the **HALO Microwave Temperature Profiler (MTP) Design Package**, Version 1.01, dated October 12, 2010 (or a later version). An almost identical instrument was delivered to the National Center for Atmospheric Research (NCAR) in Boulder, CO, and has been both mechanically and electrically certified by the US Federal Aviation Administration (FAA). In particular, all wiring meets FAA flame test standards. The HALO MTP is serial number MTPH-002.

Signed copy has been provided to DLR

Dr. MJ Mahoney
Task Manager
Jet Propulsion Laboratory

Richard F. Denning
Senior Engineer
Jet Propulsion Laboratory

Table of Contents

1	MTP Description.....	1
1.1	Background.....	1
1.2	Principal of Operation.....	1
1.3	Hardware Description.....	1
2	The HALO MTP.....	6
2.1	Overall Architecture.....	6
2.2	Connectivity.....	7
2.2.1	Wing.....	7
2.2.2	Cabin.....	7
2.2.3	Instrument.....	8
3	HALO MTP Hardware Component Details.....	9
3.1	MTP Canister Hardware.....	9
3.1.1	MTP Canister.....	9
3.1.2	MTP Fairing.....	9
3.1.3	HDPE Window.....	10
3.1.4	Reference Target.....	11
3.1.5	Scan mirror.....	12
3.1.6	Stepper motor.....	13
3.1.7	Radiometer.....	14
3.1.8	Controller Board.....	15
3.1.9	Frequency Synthesizer.....	16
3.1.10	Power Supplies.....	17
3.2	MTP Cabin Hardware.....	19
3.3	Summary of MTP Components Details.....	20
4	Electrical Description.....	21
4.1	Circuit Protection.....	21
4.1.1	Wing.....	21
4.1.2	Cabin.....	21
4.2	Load Analysis.....	22
4.2.1	Wing.....	22
4.2.2	Cabin.....	23
4.3	4.3 Wiring Used for MTP-H.....	24
4.3.1	115 VAC Wiring On Power Supply and Synthesizer Plate.....	24
4.3.2	Temperature Control bus: 120 VAC and 12 VDC.....	24
4.3.3	Main Wiring Harness.....	25
4.3.4	DC and Signal Wiring in Sub-Assemblies.....	25
5	Mechanical Description.....	26
5.1	Certification Information.....	26
5.2	HIAPER Wing Hardware.....	30
6	Software Description.....	36
6.1	PIC Software.....	36
6.2	MCC Control Software.....	36
6.3	Data Analysis Software.....	36
7	References.....	37
8	Appendices.....	38
9	Theory of MTP Measurements.....	39

HALO MTP Design Package
JPL/Caltech PROPRIETARY —Not for Public Release or Redistribution

10	Receiver Architecture Considerations	41
11	Investigation of Target Cover Materials	45
12	MTP Power and Status Panel Drawings	49
13	Temperature Control Circuits – Small_TC.....	52
14	The MTP-H Controller Board Drawings	55
14.1	Sheet 1 - Overall architecture	55
14.2	Sheet 2 - PIC Control & IO	56
14.3	Sheet 3 - VFC and Integration Counter	57
14.4	Sheet 4 - Engineering Mux and ADCs	57
14.5	Sheet 5 - Platinum Multiplexer and ADCs	57
14.6	Sheet 6 - Stepper and Synthesizer Communications	58
14.7	Sheet 7 - Accelerometer.....	59
14.8	Sheet 8 - Power Distribution.....	59
15	MTP-H Wiring.....	69
16	Temperature Controller PIC Software Listing.....	76
17	Integration Timer and Counter PIC Software Listing.....	83
18	Control and IO PIC Software Listing	91
19	MTP Mechanical Drawings	112
20	END OF DOCUMENT.....	154

Acronyms and Abbreviations

AC	alternating current
COTS	commercial off the shelf
DC	direct current
DFS	Design and Fabrication Services
DIP	dual inline package
DLR	Deutsches Zentrum für Luft- und Raumfahrt
DMT	Droplet Measurement Technologies
DSB	double side band
DSM	Data Sampling Module
EOL	Earth Observing Laboratory
FAA	Federal Aviation Administration
FPC	Flat Panel Computer
GHz	gigahertz
HDPE	high-density polyethylene
HALO	High Altitude and Long Range Research Aircraft
HIAPER	High-performance Instrumented Airborne Platform for Environmental Research
ID	inside diameter
IF	intermediate frequency
IO	input and output
IWGADTS	Interagency Working Group for Airborne Data and Telecommunications Systems
JPL	Jet Propulsion Laboratory
LED	light emitting diode
LO	local oscillator
MHz	megahertz
MTP	Microwave Temperature Profiler
NASA	National Aeronautics and Space Administration
NCAR	National Center for Atmospheric Research
NTP	Network Time Protocol
OMT	orthomode transducer
PCB	printed circuit board
PIC	programmable instrument controller
RF	radio frequency
RTD	resistive temperature detector
SPDB	Secondary Power Distribution Box
SPDDB	Secondary Power Distribution Drop Box
SPI	Serial Peripheral Interface
UCAR	University Corporation for Atmospheric Research

1 MTP Description

1.1 Background

The first airborne Microwave Temperature Profiler (MTP) flew aboard a NASA CV-990 in January 1979 and weighed more than 200 kg (Gary, 1981). A ~30 kg instrument was built in 1985 to fly on the NASA ER-2 (Denning et al., 1989). Current MTPs weigh ~10 kg, they occupy locations on the aircraft not normally used by other instruments, they can run unattended, and they make measurements at microwave frequencies which are not affected by the presence of clouds. To date, MTPs have flown on 53 field deployments, and have accumulated 4696 flight hours on 824 flights.

1.2 Principal of Operation

The MTP is a passive microwave radiometer that measures, at several frequencies, the thermal rotational-line emission from oxygen molecules in the Earth's atmosphere. The instrument uses a scanning mirror to view ten elevation angles from the zenith to nadir in the flight direction (Denning et al. 1989). The measured microwave brightness temperatures, or observables, are then converted to a vertical temperature profile along the flight track by using a statistical retrieval procedure (Strand and Westwater 1968) with Bayesian aspects. To do this, a forward radiative transfer calculation must first be made. Hundreds of radiosondes, which are representative of the season and location of the actual measurements, are used to calculate the expected brightness temperatures for each radiosonde temperature profile. These calculations must be done for all flight levels. A linear multiple regression is then used to statistically relate the expected brightness temperatures (from the forward radiative transfer calculation) to physical temperature profiles (from the hundreds of radiosondes). This results in a set of retrieval coefficients that can be used to convert actual measured brightness temperatures to a physical temperature profile. Retrieval accuracy is improved by using radiosondes that are flown by as templates to select the others needed to calculate a set of retrieval coefficients. An information-theory-based metric then compares the measured observables to the average calculated observables for each retrieval coefficient set, and determines which set (or pair of sets) of retrieval coefficients to use for the temperature profile retrieval. A temperature profile has a vertical resolution of ~150 m near flight level, and degrades with distance from the aircraft. More information on the theory of MTP measurements can be found in **Appendix A**.

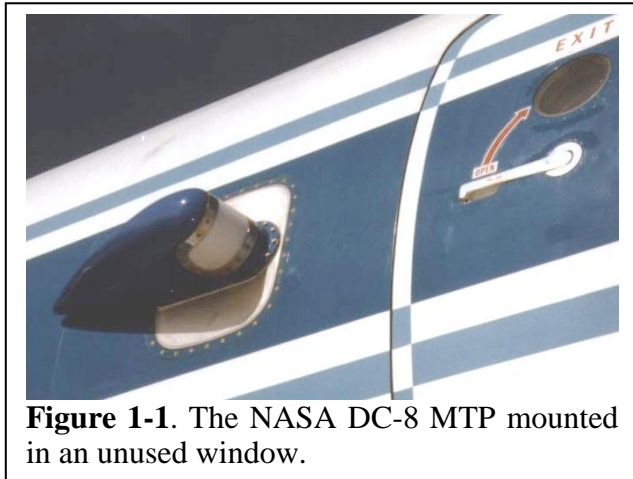

1.3 Hardware Description

The DLR High Altitude and LOng research aircraft (HALO) MTP is essentially a copy of the MTP that we built and delivered to NCAR for their G-V research aircraft called HIAPER. It was originally proposed that the HIAPER MTP would be a close copy of the

current DC-8 MTP (**Figure 1-1**). All of the electronics for this instrument are mounted on the back of a window blank. The MTP is controlled by a rack-mounted, flat panel computer located on a bulkhead behind the forward starboard Exit door. Previously, all MTPs consisted of two components: a Sensor Unit, which contained the receiver and related electronics, and a Data Unit, which controlled the Sensor Unit and recorded data from it (**Figure 1-2**). The DC-8

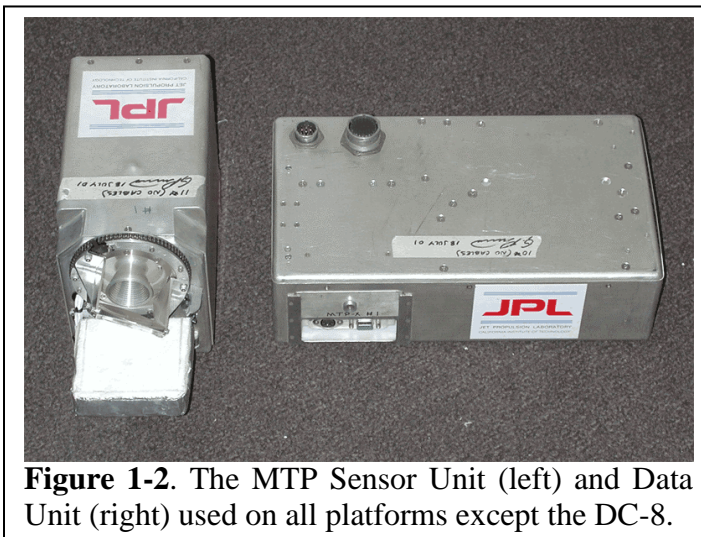

Figure 1-2. The MTP Sensor Unit (left) and Data Unit (right) used on all platforms except the DC-8.

MTP simplification of having the hardware in a single enclosure was made possible by the use of several micro-controllers and “smart” peripheral chips to replace many standard logic and analog integrated circuits. For example, the integration timer/counter that reads the output of the radiometer voltage-to-frequency converter previously required nine 74HC DIP packages of 14 to 16 pins. It was replaced by a single 18-pin dual inline package (Microchip 16F628) and a ceramic resonator.

We had proposed to mount the HIAPER MTP in a window similar to the DC-8 MTP shown in **Figure 1-1**. However, concerns about the cost and time involved for anti-icing certification led us to consider other options. The one that we decided on was to mount the MTP on the front of a DMT canister, far enough forward to have the scanning mirror

beam clear the leading edge of the GV wing. A drawing of the HIAPER MTP is shown in **Figure 1-3**. It weighs 18.2 kg (including the fairing and Droplet Measurement Technologies (DMT) canister, but not the cabin control computer and cables.) Because a DMT canister is not included with the HALO MTP, it weighs 12.5 kg. The canister itself is attached to one of three wing hard points on each wing by a strut. The MTP requires a fairing with a microwave-transparent high-density polyethylene (HDPE) window to protect it from the elements.

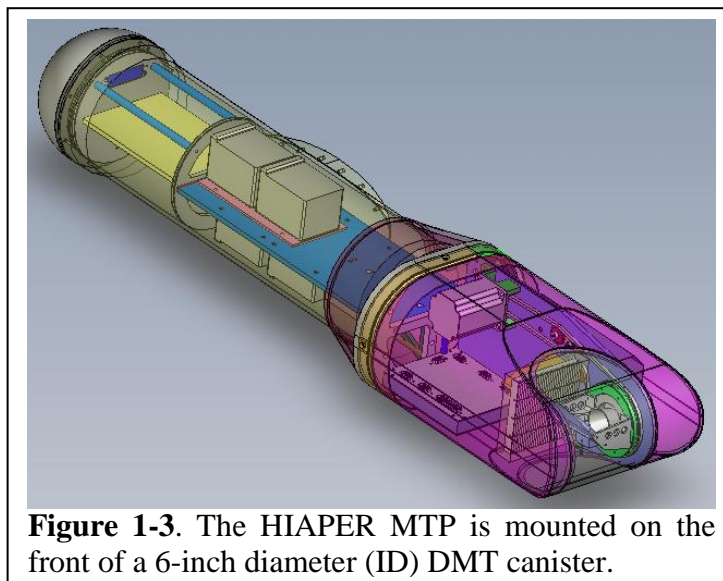
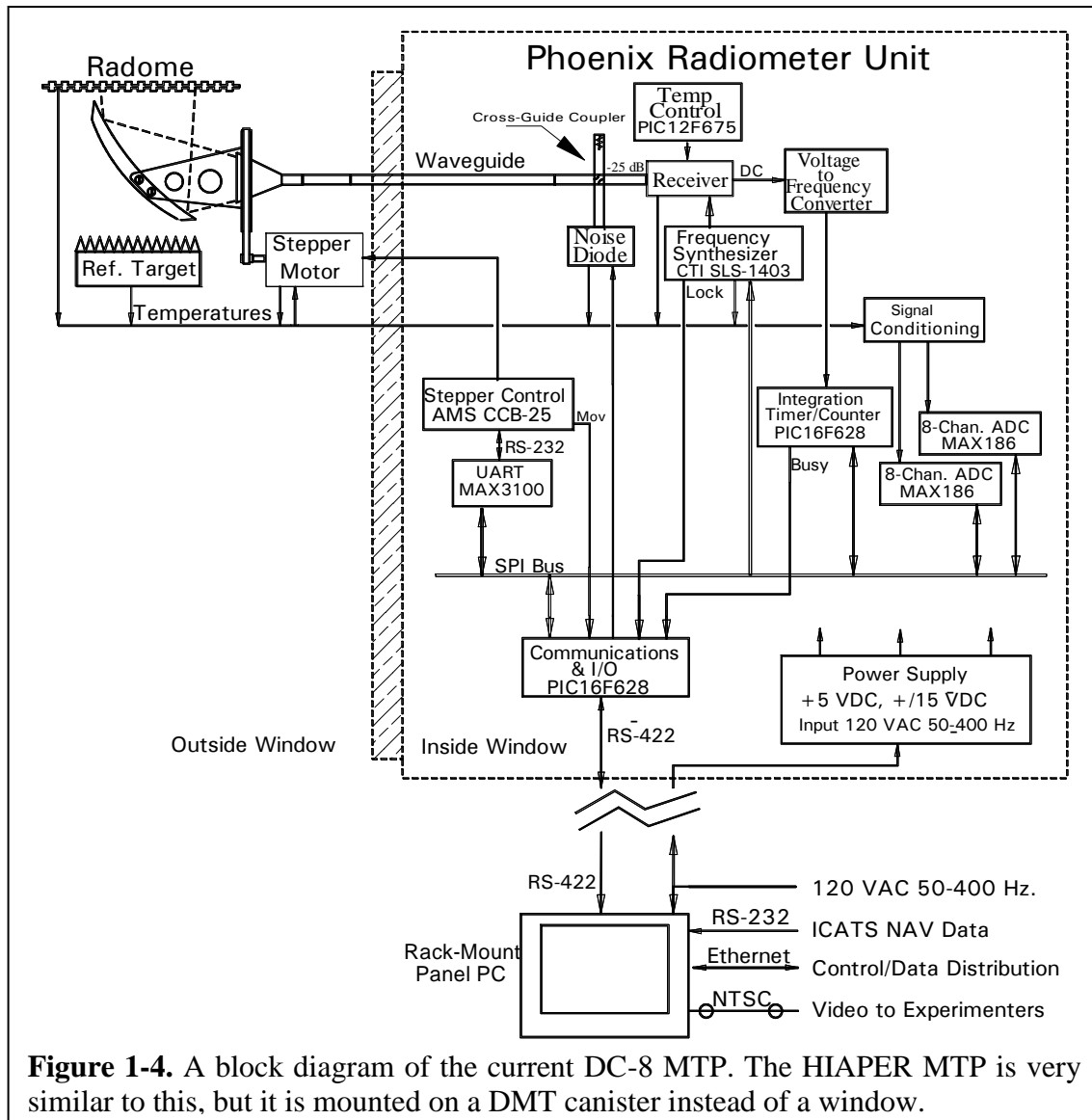

Figure 1-3. The HIAPER MTP is mounted on the front of a 6-inch diameter (ID) DMT canister.

Figure 1-4 shows a block diagram of the current DC-8 MTP on which the HIAPER instrument is based. A flat panel computer (FPC) running under Windows 2000 controls



the operation of the radiometer, records the data, performs the analyses, and displays the temperature profiles as they are retrieved. Between the MTP and the FPC there is an RS-422 serial connection allowing the computer to be located anywhere in the aircraft cabin. Since all control functions are in one computer with access to and from the Ethernet, the entire scan and frequency tuning sequence is available to the MTP experimenter, if present or if there is a satellite connection from the ground, for modification during flight. Parameters such as mounting offsets, integration time, frequencies and scan angles are contained in a configuration file that can be changed at any time. Other experimenters can obtain numerical data or temperature profile images during flight over the GVs display and user data traffic network. If an MTP experimenter is on board or has access via a satellite connection, he/she can control the instrument or download data files, or even edit programs on the FPC.

There are three minor changes that were implemented for the HIAPER MTP compared to the DC-8 MTP. Because it was a prototype, the current DC-8 MTP digital circuitry was

implemented on a wire-wrap board rather than a printed circuit board (PCB). The DC-8 wire-wrap design has been converted to a multi-layer PCB. This allows us to inexpensively make spare PCBs. This PCB design was optimized for the HIAPER MTP using surface mount hardware and several programmable interface controllers (PICs).

The second minor change was the following. The HIAPER MTP uses the Network Time Protocol (NTP), which has a latency of 1 ms, to synchronize the MTP measurements to the other measurements on the aircraft. There was no time synchronization on the DC-8.

The third minor change involved changing the double side band (DSB) receiver to operate with the IF at base band instead of 320 MHz (as is case for all our existing instruments). This simplifies the data analysis and improves the quality of the retrievals.

There are additional changes that have been made for the HALO MTP. While each wing strut on HIAPER can carry two DMT canisters, HALO uses a custom enclosure that can carry the equivalent of three DMT canisters, but without the canisters. This is shown in **Figure 1-5**.

Another major difference between the HALO and HIAPER MTPs is that the HIAPER MTP is controlled by a rack-mounted computer in the cabin, where there is also a Power and Status Panel to turn the instrument and/or computer on and off. Data and control signals between the control computer in the HIAPER cabin and the MTP instrument in the canister are transmitted using copper wires on HIAPER, whereas on HALO control will be via Ethernet UDP packets from a laptop computer somewhere in the HALO cabin. Finally, on HIAPER the program which controls the MTP is run under Visual Basic 6.0, while on HALO a LabView 8.6 program has been written to perform the same function on a PC-104 computer located in the wing store are aft of the MTP. The laptop computer in the HALO cabin performs the function of the Power and Status Panel as it can turn the MTP on and off.

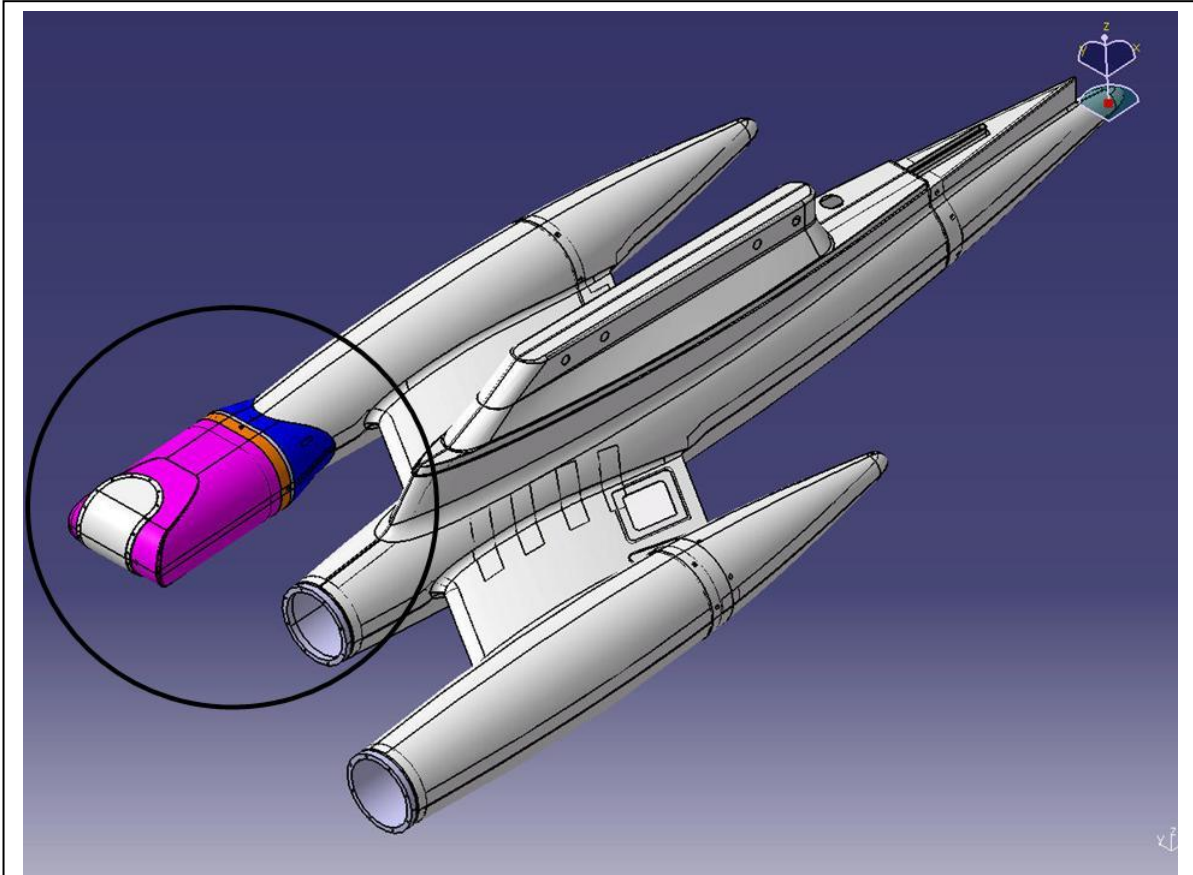

Figure 1-5. The HALO MTP (circled) mounted on the front of a DLR custom-built carrier for standard DMT canisters. The blue-colored back fairing was custom built by Aerostruktur Faserverbundtechnik GmbH, Gundelfingen, Germany. Image courtesy of DLR.

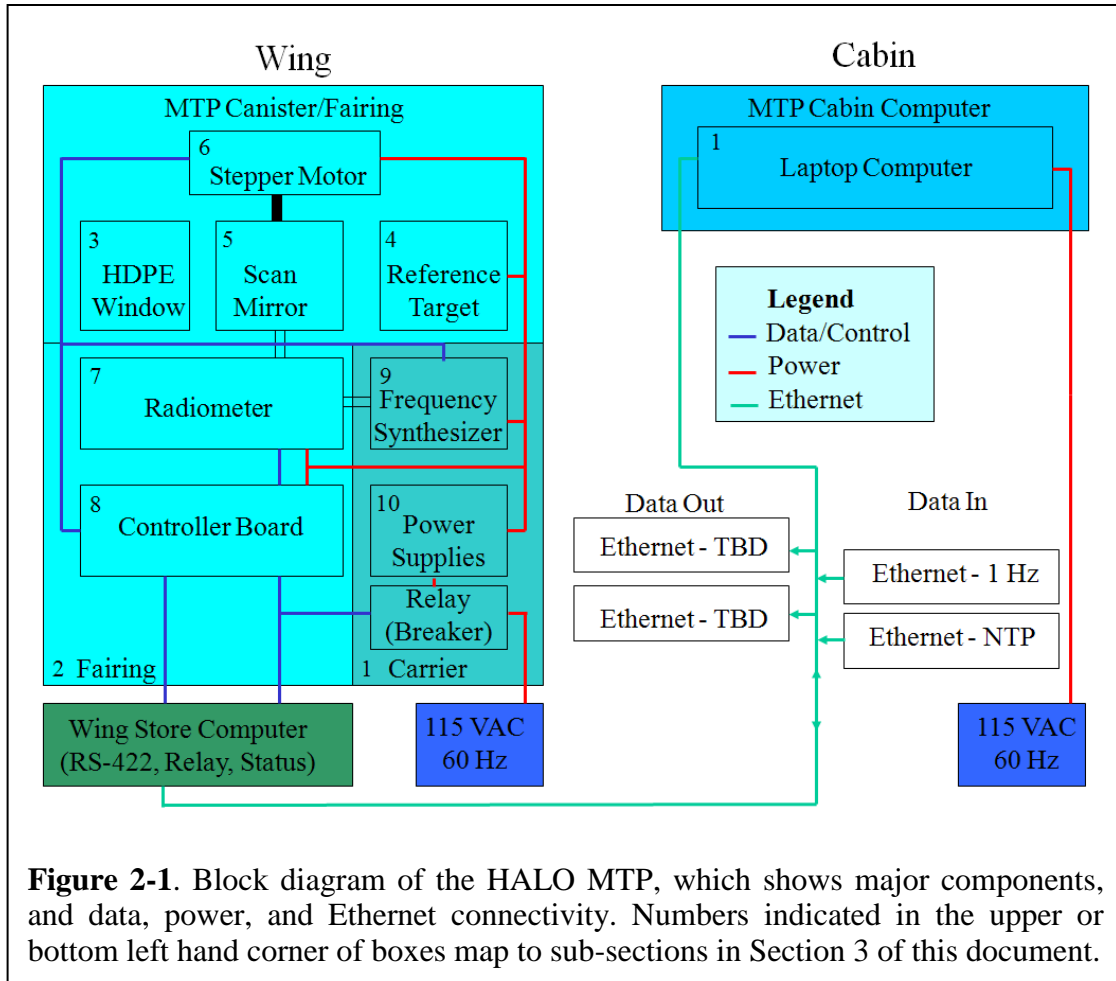

Figure 2-1. Block diagram of the HALO MTP, which shows major components, and data, power, and Ethernet connectivity. Numbers indicated in the upper or bottom left hand corner of boxes map to sub-sections in Section 3 of this document.

2 The HALO MTP

2.1 Overall Architecture

The overall architecture of the HALO MTP is shown in **Figure 2-1**. As shown on the left, most of the MTP components are located inside a fiberglass *Fairing* (2) on the front of a custom-made *Carrier* (1) that can receive three instruments designed to mount in a standard aluminum DMT canister (see **Figure 1-5**). The fairing will contain a *HDPE Window* (3) for viewing through using a *Scan Mirror* (5) inside the fairing, which is driven by a *Stepper Motor* (6). In addition to viewing ten different elevation angles from near-zenith to near-nadir in the flight direction, the *Scan Mirror* also views a *Reference Target* (4) for gain calibration purposes. The RF signal received by the *Scan Mirror* connects to the *Radiometer* (7), which is mounted on a thermally isolated temperature-controlled plate. A microwave signal from a *Frequency Synthesizer* (9) is fed into the *Radiometer* to down-convert the RF signal to baseband. The *Frequency Synthesizer* and *Power Supplies* (10) are located in the *Carrier* (1) itself, which is mounted on a wing hard point strut.

The detected baseband signal is processed by a voltage-to-frequency converter (VFC), and that signal is sent to the *Controller Board* (8), which communicates with the PC-104 Wing Store Computer (WSC). The *Controller Board* also receives and processes commands from the WSC and sends data back to the WSC. The WSC records this data and retrieves real time temperature profiles. The raw data can also be recorded elsewhere on the Ethernet (TBD).

Small PIC-based *Temperature Controller Boards* are used at four locations in the MTP to maintain stable temperatures and to prevent condensation on descent after cold soaking. These locations are the *Reference Target*, the *Radiometer Plate*, *Power Supply/Synthesizer Plate*, and the *Controller Board* enclosure. The controllers all operate near 40 C.

2.2 Connectivity

2.2.1 Wing

The connection between the MTP and WSC is done using RS-422 communications. The MTP is powered from wing store 115 VAC 400 Hz power via a relay controlled by software on the *MTP Cabin Computer (MCC)* (a laptop computer). The MCC is also powered by 115 VAC 400 Hz power from the cabin. Section 4 provides a detailed power load analysis. We now provide a more detailed description of the MTP cabin and instrument connectivity shown in **Figure 2-1**.

2.2.2 Cabin

As mentioned earlier, the MCC for HALO is trivial compared to HIAPER, which involved a rack-mounted computer and Power and Status Panel. The rack-mounted computer is replaced by a laptop computer and the Power and Status Panel is replaced by LabView software running on the laptop. All comm

An LED on the *Power and Status Panel* indicates that power is available to the rack. Another LED indicates that power is available at the MTP canister. The condition in which power is available in the canister, but the ‘Operate’ toggle switch has not been turned on, is the ‘Standby’ mode. In Standby mode only canister temperature controllers are operating.

The cabin MTP non-power-connectivity is shown by the blue lines on the right side of **Figure 2-1**. Control signals from the computer are sent and data returned via an RS-422 interface between the MCC and the MTP. Data from the MTP and other on-board sources are combined into data files recorded on the MCC for real-time analysis and display. The raw data is also sent to the ADS3 to be recorded for backup. The MCC performs real time temperature profile retrievals. Images of these profiles (and other data products) are available on the user data traffic network.

To properly point the MTP, real time pitch and roll are required. These are acquired from the 1 Hz IWGADTS (see References) ASCII data stream. Its 2-3 second latency is much better than the current 10-15 second latency of other existing MTPs, which have acceptable pointing performance. If there is a need to reduce the latency this could be

done by receiving an ARINC-429 signal from the aircraft Inertial Reference System. Time synchronization is obtained from a broadcast Ethernet NTP signal.

2.2.3 Instrument

Top level instrument power connectivity is shown as red lines on the left side in **Figure 2-1**, while the control/data connectivity as shown as blue lines. In addition to wiring, there is waveguide connectivity between the receiver components, and from the frequency synthesizer (local oscillator) to the mixer in the receiver. Detailed information on the instrument wiring can be found in the appendices.

There are two classes of measurements in the MTP: (1) radiometric, that is, data used directly in calculating brightness temperatures, which includes the radiometer output as well as the temperatures of certain key components, and (2) engineering values such as power supply voltages, motor temperature, power supply temperature, etc. that are used to evaluate and diagnose the health of the instrument.

3 HALO MTP Hardware Component Details

3.1 MTP Canister Hardware



Figure 3-1. HIAPER MTP fairing (white), DMT canister (gold) and HDPE window (white). The HALO MTP will use a custom composite canister carrier (**Figure 1-5**)

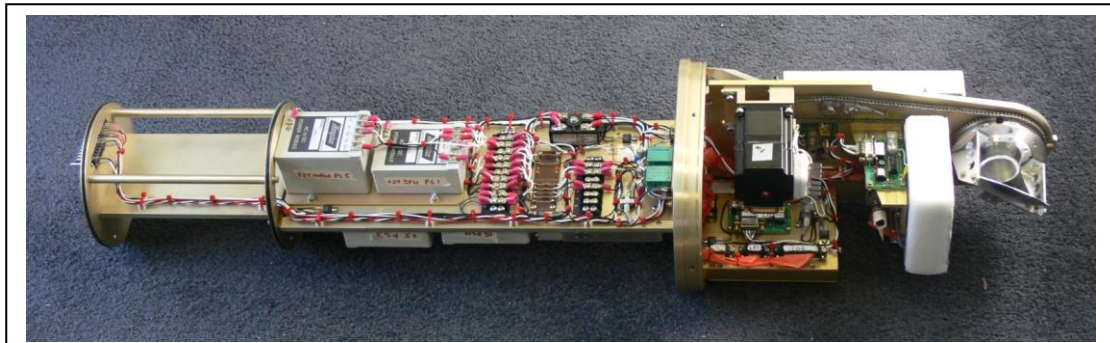

Figure 3-2. The HALO MTP without the fairing, which is mounted on the front (right), and custom canister carrier.

3.1.1 MTP Canister

Source: DLR

Material: Custom composite (see **Figure 1-5**.)

Description: Unlike the HIAPER MTP which is mounted in a standard DMT six-inch canister (see **Figure 3-1**), the HALO MTP is mounted in a custom composite structure.

3.1.2 MTP Fairing

Source: Zivko Aeronautics, Inc., Guthrie, OK, USA.

Material: Fiberglass with Al attach fitting

Description: The fairing protects the MTP hardware from the environment.

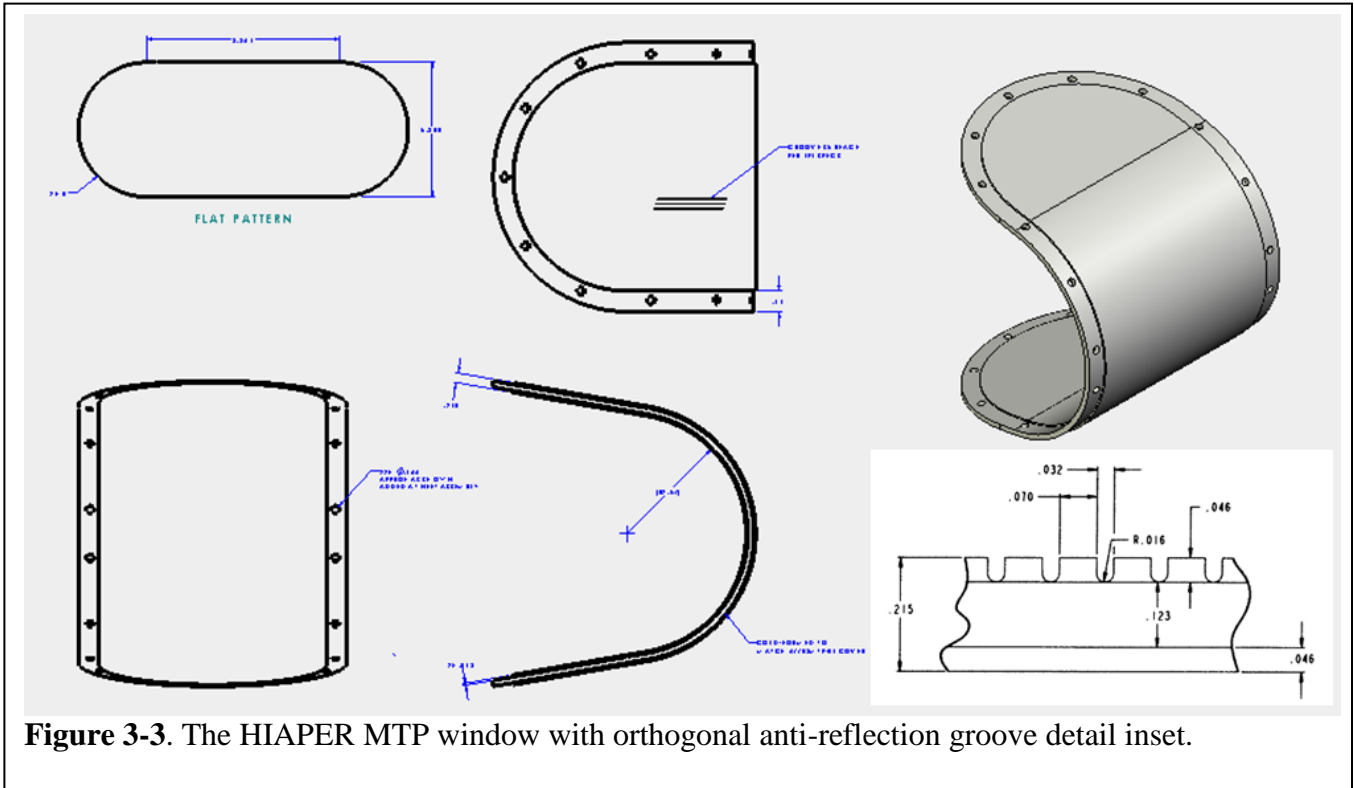

Figure 3-3. The HIAPER MTP window with orthogonal anti-reflection groove detail inset.

3.1.3 HDPE Window

Source: NCAR/EOL/DFS

Material: High-density polyethylene (HDPE)

Description: HDPE is microwave transparent and allows the MTP scan mirror to view outside the fairing. The window has groves machined on each side which are orthogonal, to serve as an anti-reflection ‘coating’. The groves are separated by 0.102 inches, are 0.032 inches wide and are 0.046 inches deep. The thickness of the machined HDPE sheet is 0.215 inches.

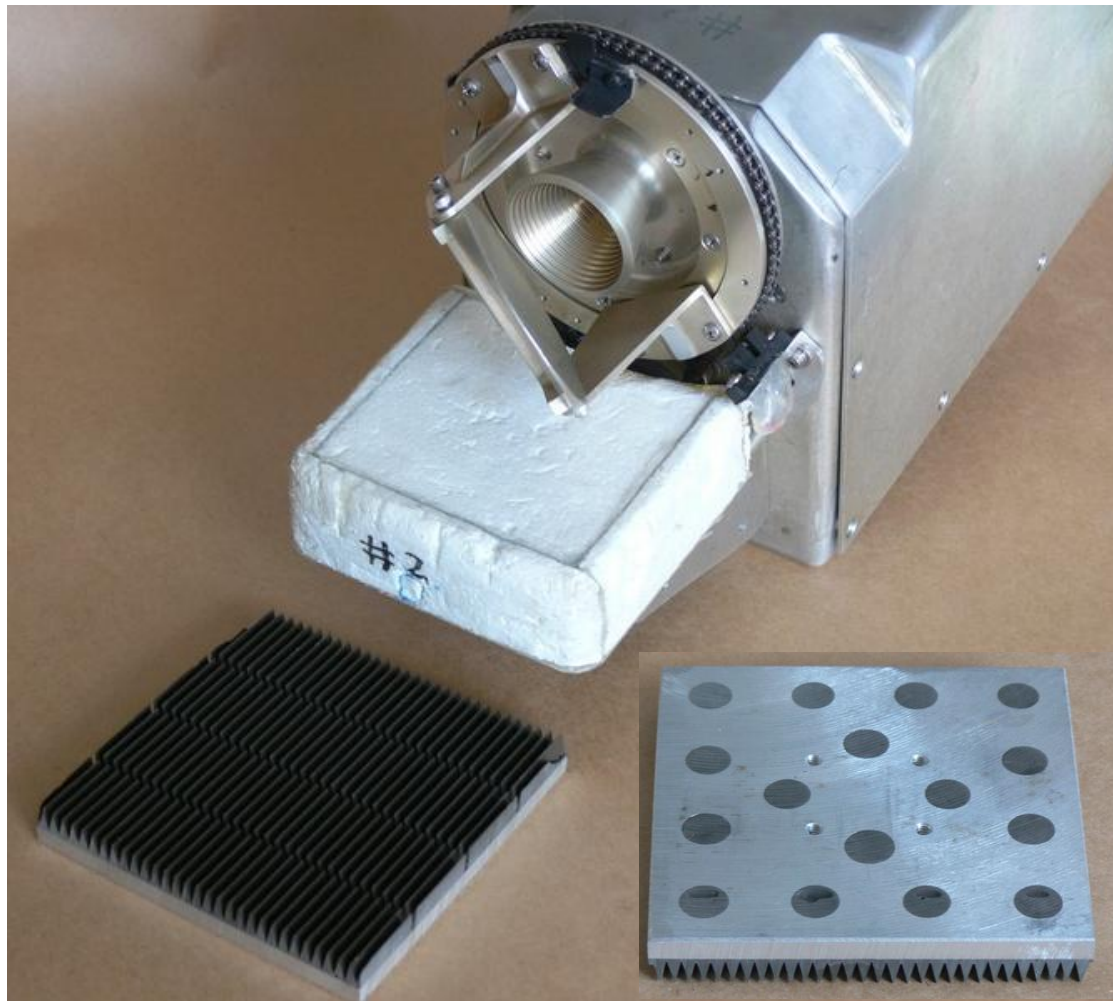

Figure 3-4. ER-2 Sensor Unit #2 is shown enclosed in $\frac{1}{4}$ " thick Styrofoam to control thermal gradients and to provide a long thermal time constant. A top view of the target is shown in front of the enclosed target, and the metal backing is shown to the right.

3.1.4 Reference Target

Source: JPL

Material: Carbon-ferrite mounted on an aluminum plate
Styrofoam and ROHACELL foam insulation

Power: 115 VAC 60 Hz 0.5 A max for heater

Description: The reference target temperature is used in combination with the outside air temperature to calculate the gain of the MTP. The target is 4 inches x 4 inches and about 1 inch deep, and it is surrounded by $\frac{1}{4}$ inch foam insulation. All our existing MTPs use polystyrene foam (Styrofoam) to thermally insulate the target. As discussed in Section 11 we considered other materials for insulation because of the flammability issues with using polystyrene. We found a new polyethylene foam (PLASTAZOTE LD15) which has better electrical properties than Styrofoam, and initially used it on the front face of the target. However, it did not hold up and was replaced with Styrofoam. ROHACELL foam insulation was used on the other faces as it meets FAA flammability requirements.



Figure 3-5. Scan mirror, corrugated feed horn, chain drive, and orthomode transducer. Note that the sprocket for the chain drive is mounted outside of the original belt drive sprocket. This was done so that the reference target could be mounted closer to the antenna. Previously, it was mounted in place of the original belt drive sprocket.

3.1.5 Scan mirror

Source: JPL Microwave Sounder Unit (MSU) satellite spare

Material: Aluminum

Description: The scan mirror is used to view ten different elevation angles from near zenith to near nadir in the flight direction. It also scans to a reference target for calibration purposes. The scan mirror has a beam width of 7.5° FWHM, and re-directs the beam 90° into a conical, corrugated feed horn.

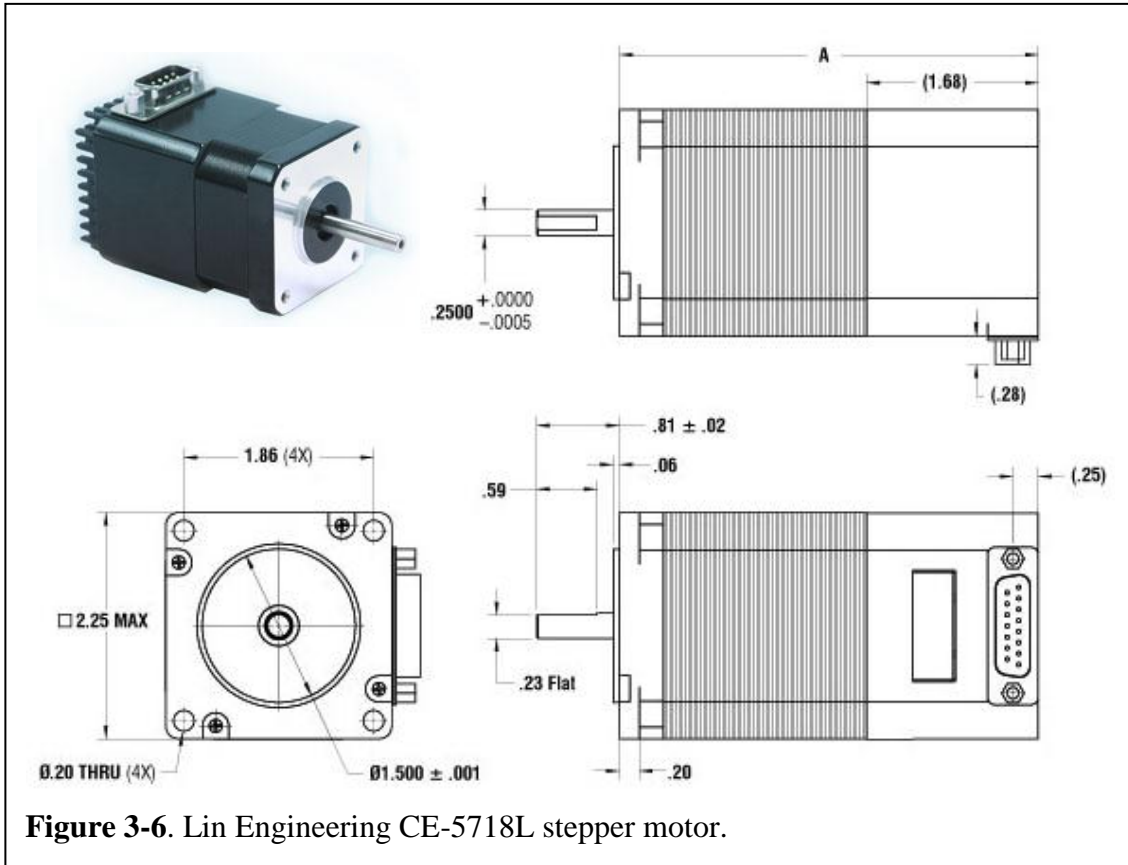

Figure 3-6. Lin Engineering CE-5718L stepper motor.

3.1.6 Stepper motor

Source: Lin Engineering, Morgan Hill, CA, USA.

Part Number: CE-5718L-01PD-20 with 200 cpr encoder

Power: 12-40 VDC @ 3 A max, will operate at +24 VDC, 2 A max

Description: The stepper motor is used to point the MTP scan mirror. It has a shaft encoder to verify position, and an integrated controller that operates via an RS-485 interface.

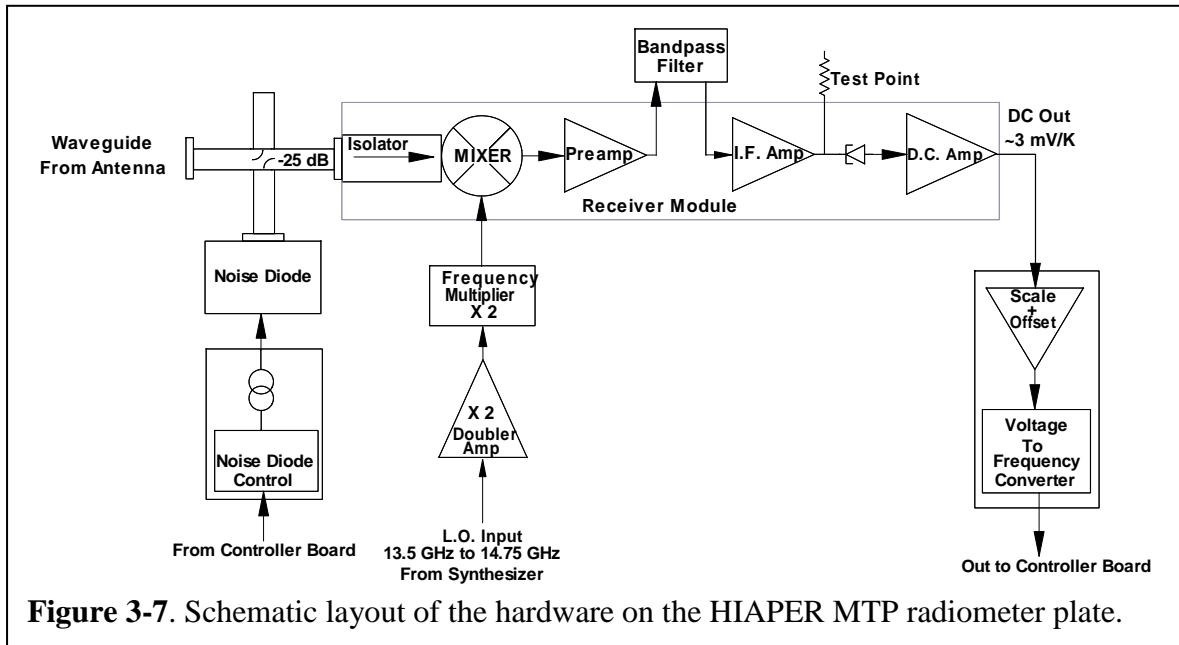

Figure 3-7. Schematic layout of the hardware on the HIAPER MTP radiometer plate.

3.1.7 Radiometer

Source: Custom built by Spacek Labs, Inc, Santa Barbara, CA

Material: Mostly metal

Power: 15 VDC @ 200 mA (max)

Description: The signal received from the corrugated feed horn on the scan system is converted into orthogonal linear polarizations in an orthomode transducer (OMT) attached to the base of the feed horn. A load is put on one linear polarization and the other is conveyed in waveguide to the radiometer. The radiometer consists of a cross-guide coupler for injection of a noise diode calibration signal, followed by an isolator to prevent local oscillator (LO) signal leakage. Next is a double-side-band biased mixer, which mixes the incoming radio frequency (RF) signal with the LO signal. The LO signal is derived from the frequency synthesizer, by first doubling the signal in an active doubling amplifier, which is followed by a passive doubler. Unlike our current mixers, the HIAPER mixer down converts to base band with the lowest frequency ~10 MHz. This is followed by amplification and an intermediate frequency (IF) filter to select the pass band which is nominally ~200 MHz, but can be larger or smaller depending on the application simply by changing the IF filter. The IF signal is detected and processed by a voltage-to-frequency converter, and then sent to the *Controller Board* for counting. **Section 9** provides more detail on how we arrived at this particular radiometer architecture, which is essentially the same as what we currently employ in our other instruments. We had wanted to use another architecture, which had definite advantages, but the performance would not have been as good.

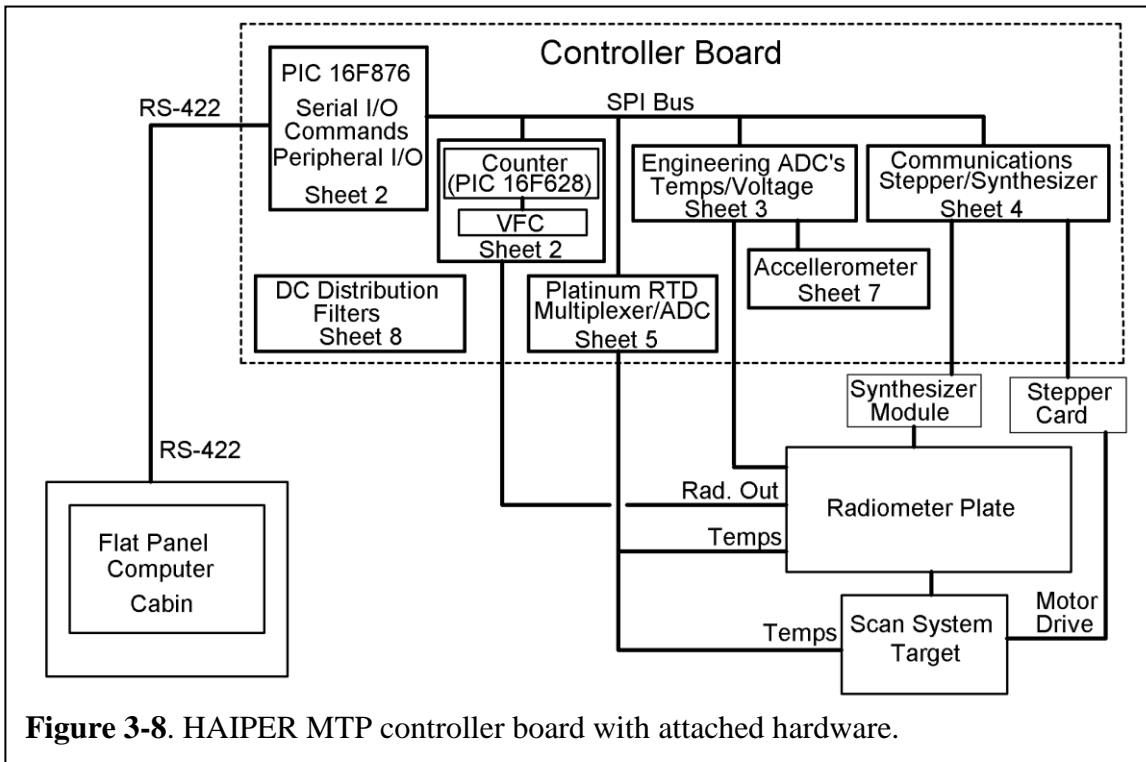

Figure 3-8. HAIPER MTP controller board with attached hardware.

3.1.8 Controller Board

Source: Multilayer PCB board designed by JPL and manufactured by a third party.
Description: A single multilayer printed circuit board is used to control all of the MTP hardware. It is 4 inches by 5 inches in size, and uses surface mount devices. The *Controller Board* has two programmable integrated circuits (PICs) performing different functions. As shown in **Figure 3-8**, one PIC controls the asynchronous RS-422 IO with the MTP Cabin Computer, and communicates with the other hardware over a serial peripheral interface (SPI) bus. On the SPI bus, a second PIC counts the signal from the *Radiometer* voltage-to-frequency converter (VFC).

The *LO* frequency synthesizer is controlled directly as a device on the SPI bus, and the stepper motor is controlled via an RS-485 interface through an SPI UART. The SPI bus also controls the multiplexing and A/D conversions needed to read resistance data from six platinum resistive temperature devices (RTDs). The RTDs are placed on instrument components requiring stable temperature measurement for data processing purposes, such as the *Reference Target*, *HDPE Window*, and components in the *Radiometer*. (Eight channels are available on the RTD multiplexer of which two are used for precision calibration resistors, which have an extremely low temperature coefficient.) Less critical temperatures and voltages are measured on a separate 16-channel engineering data multiplexer. This multiplexer also receives data from a vertical accelerometer. **Section 13** in the appendix shows a complete layout of the *Controller Board*.

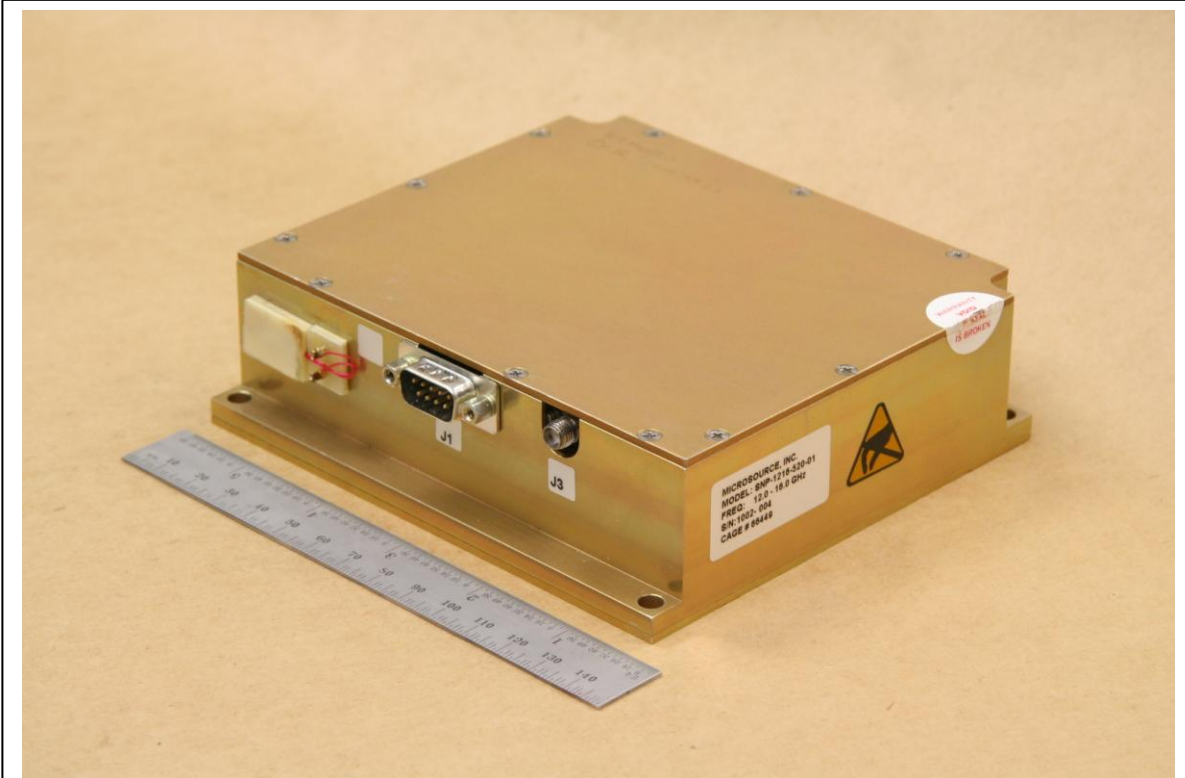

Figure 3-9. Giga-tronics/Microsource, Inc., Frequency synthesizer.

3.1.9 Frequency Synthesizer

Source: Giga-tronics/MicroSource, Inc., San Ramon, CA, USA

Part Number: Ultra-Low Noise Synthesizer, 12-16 GHz, MSI

Model No. SNP-1216-520-01

Material: Various

Power: 24 VDC @ 310 mA (500 mA max)

Description: This wide band YIG-tuned synthesizer has 1 Hz resolution and can be tuned for an output frequency from 12.0 to 16.0 GHz. The power output across the band is 17 dBm. The output from the synthesizer is amplified in a doubling amplifier. It in turn drives a passive doubler, which generates the final local oscillator (LO) signal needed for the MTP heterodyne receiver. The size of the package is 5.0" x 5.5" x 1.6".

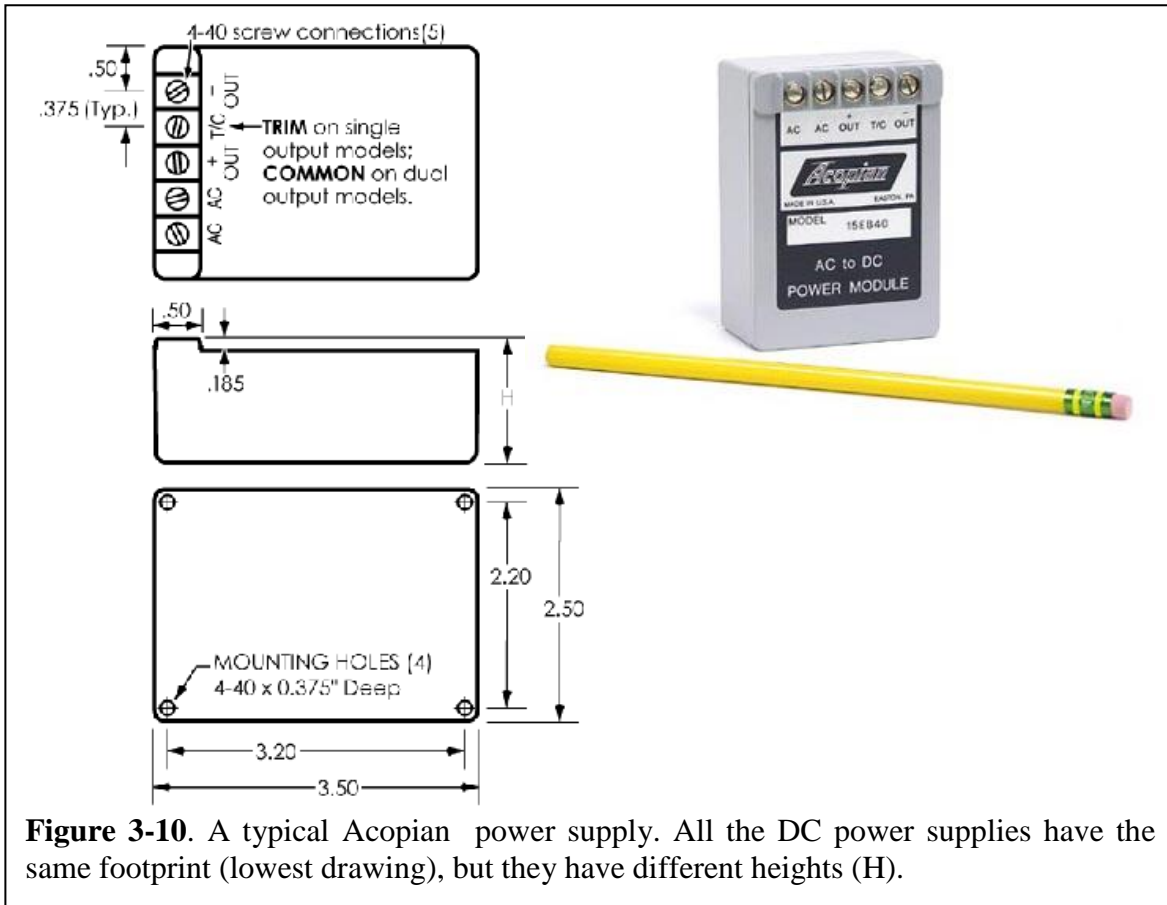

3.1.10 Power Supplies

Source: Acopian Technical Company, Easton, PA, USA.

Part Numbers	Detail	PS Number
24WB210	+24 V @ 2.10 Amp max, switching regulated	5
15WB330	+15 V @ 3.30 Amp max, switching regulated	1
15WB200	+15 V @ 2.00 Amp max, switching regulated	2
15EB40	-15 V @ 0.40 Amp max, linear regulated	4
5EB100	+5 V @ 1.00 Amp max, linear regulated	3
5EB100	+5 V @ 1.00 Amp max, linear regulated	6

Description: Six (6) modular power supplies are used to convert aircraft 115 VAC 60 Hz aircraft power to the DC voltages needed for the MTP. The PS Number above is the power supply number on the wiring diagram on page 72. The +24 V switching regulated supply is used for the *Stepper Motor*. There are two +15 V switching regulated supplies: one is used for the *LO* frequency synthesizer and the noise diode, and the other is used for the *IF* and *LO* amplifiers. A -15V linear regulated supply is used for analog circuits in the receiver and the *Controller Board*. There are two +5V linear regulated supplies: one for the *Controller Board*, and a separate one for the *Temperature Control System* to provide logic power when the MTP is in Standby mode. All these supplies can handle 60 or 400 Hz, and they all have the same footprint, but vary in height.

In addition to the DC power supplies just described, the MTP also uses 115 VAC 60 Hz for heater power. As mentioned above, heaters controlled by *Temperature Controller Boards* are used to control the temperature of the *Radiometer* box, the *Reference Target*, the *Power Supplies/Synthesizer Plate* and the *Controller Board* enclosure. The heaters improve performance by maintaining temperature stability and they prevent condensation on descent after cold soaking. These heater loads represent another 4 x 115VAC @ 0.5 Amp (max) added to the total power requirement. A detailed power load analysis is provided in **Section 4**.

3.2 MTP Cabin Hardware

For the HIAPER MTP, in order to minimize the amount of space that the MTP control computer (which is located in the cabin) would require, we used a rack-mounted computer with a display included in a separate keyboard drawer. As a result only 5.25 inches of rack space (3U) are required to mount the *MTP Control Computer* (1U), the *Keyboard and Display Drawer* (1U) and *Power and Status Panel* (1U). As mentioned in Section 1.3, the HALO MTP does not use any of this hardware. However, we describe it here because DLR may wish to copy this implementation on some other platform.

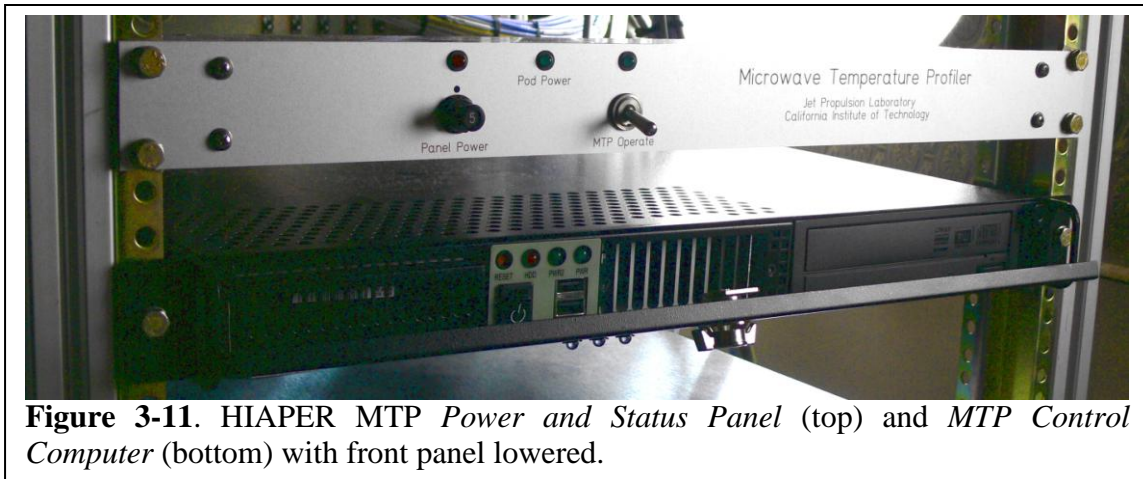

Figure 3-11. HIAPER MTP *Power and Status Panel* (top) and *MTP Control Computer* (bottom) with front panel lowered.

In the HIAPER configuration, when wing power from the wing store is available to the MTP, the pod power on (PODPWRON) signal line will turn on the POD PWR LED. The MTP has a 5-volt power supply that is activated by the presence of wing power. Although the instrument is not yet on, wing power does turn on the four temperature controllers in the instrument. The controller logic is run from one of the two 5-v supplies although the heater resistors use the AC power. The presence of the 5-v power is what energizes the PODPWRON signal. When the POD PWR ON LED is lit on the *Power and Status Panel*, the instrument can be turned on. This is done by switching the MTP ON toggle switch. This switch sends the MTP operate (MTP_OPR) signal to a relay on the *Power Supply and Synthesizer Plate* in the instrument. When the relay turns on, it returns the operate power on (OPPWRON) signal back to the *Power and Status Panel*, which turns on the MTP ON LED. If for any reason the instrument fails to cycle properly, the MTP ON LED will turn off.

3.3 Summary of MTP Components Details

The **Table 3.1** lists the major MTP components, referring to the section (Sec) in which they were discussed above, whether they are commercial off the shelf (COTS), and their source.

Sec	Component	COTS?	Source
3.1.1	DMT Canister	Y	DMT, Boulder, CO
3.1.2	Fairing	N	Zivko Aeronautics, Guthrie, OK
3.1.3	HDPE Window and Mounting Hardware	N	EOL/DFS build
3.1.4	Reference Target	N	JPL build
3.1.5	Scan Mirror	N	JPL MSU Spare
3.1.6	Stepper Motor	Y	Lin Engineering, Morgan Hill, CA
3.1.7	Radiometer	N	Spacek Labs, Inc., Santa Barbara, CA
3.1.8	Controller Board	N	JPL build
3.1.9	Frequency Synthesizer	Y	Giga-tronics, San Ramon, CA
3.1.10	Power Supplies	Y	Acopian Technical Co., Easton, PA

Table 3-1. MTP COTS components.

4 Electrical Description

4.1 Circuit Protection

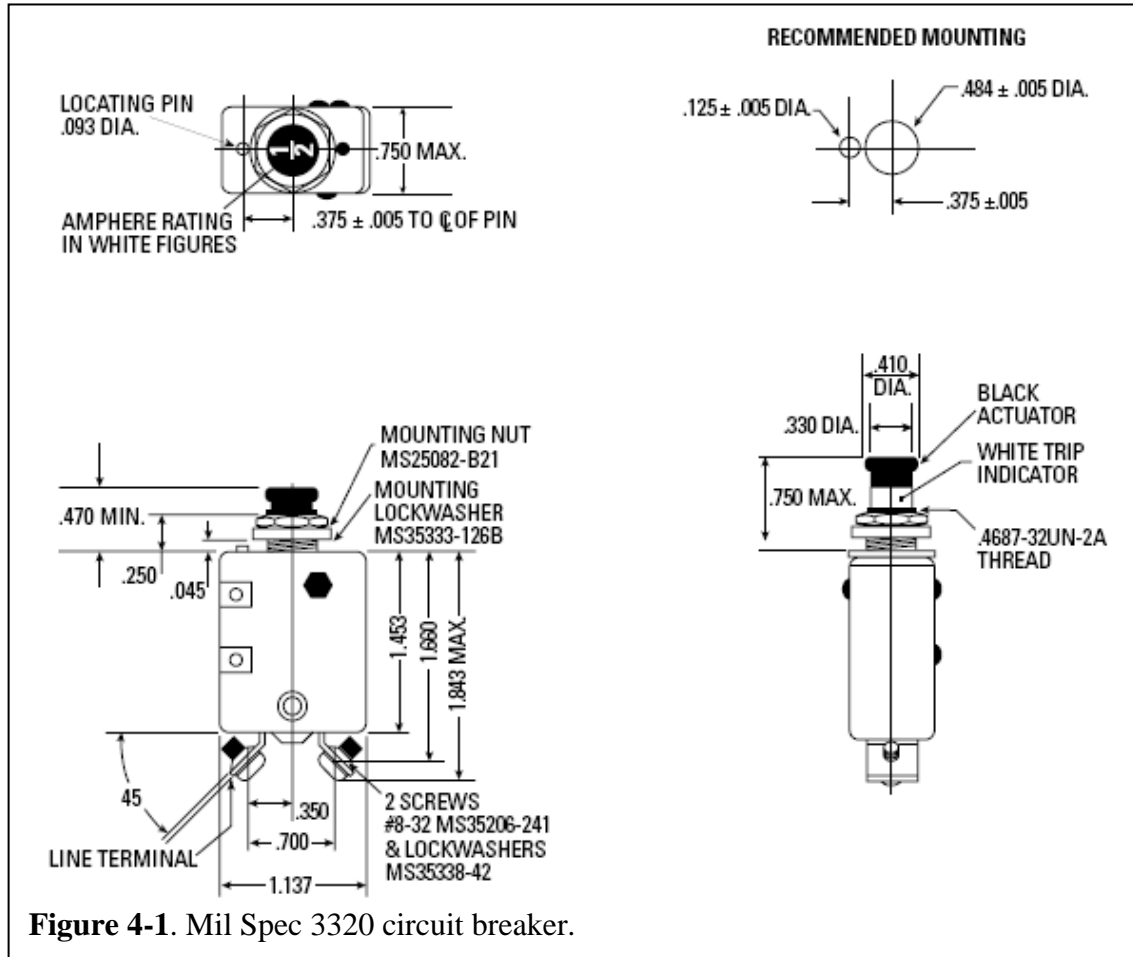

Figure 4-1. Mil Spec 3320 circuit breaker.

4.1.1 Wing

There will be two circuit breakers in the wing for the MTP 115 VAC power. One is for the heater circuit whenever wing power is available, and the other is for the main instrument power which comes on when the MTP Power On toggle switch is turned on at the MTP cabin *Power and Status Panel*. Both of these circuit breakers are Mil Spec. MS3320 5 A breakers (e.g., Eaton part number 1500-052-5) as shown in **Figure 4-1**.

4.1.2 Cabin

Power for the *MTP Cabin Computer* (1U Rack-mounted Computer, and 1U Keyboard and Display Drawer) is provided from the *Power and Status Panel*. 115 VAC power to the *Power and Status Panel* comes from a SPDB or SPDDB, and is protected by Mil Spec. MS3320 5 A breaker (e.g., Eaton part number 1500-052-5).

Acopian Model	PS No.	DC Voltage (volts)	DC Current (amps)	DC Power (watts)	115 VAC 60 Hz (amps)*
24WB210	5	+24	2.10	50.40	0.58
15WB330	1	+15	3.30	49.50	0.57
15WB200	2	+15	2.00	30.00	0.34
15EB40	4	-15	0.40	6.00	0.07
5EB100	3	+5	1.00	5.00	0.06
5EB100	6	+5	1.00	5.00	0.06
Total				145.90	1.67

*Assumes typical Acopian power-supply efficiency of 76%

PS No. is the Power Supply number from the wiring diagram on page 72.

Table 4-1. Maximum DC power-supply load summary and equivalent 115 VAC current.

4.2 Load Analysis

4.2.1 Wing

As is shown in **Table 4-1** there are six DC power supplies for the MTP mounted in a DMT canister using 115 VAC 60 Hz power. They are used as follows, where the leading PSn is the Power Supply designation in the wiring drawing on page 72:

PS1, the large +15V supply powers the *Frequency Synthesizer*,

PS2, the +15 V supply powers the IF amplifier and the frequency doubling amplifier, as well as +15 V analog circuits on the *Controller Board*,

PS3, one +5 V supply powers logic circuits, and the other

PS4, the -15 V supply powers the IF amplifier and -15 V analog circuits on the *Controller Board*,

PS5, the large +24V supply powers the *Stepper Motor*,

PS6, +5 V supply powers circuitry on the *Temperature Controller Boards*. It operates in both “Standby” and “Operate” modes.

When the instrument is turned on from the cabin *Power and Status Panel*, the total 115 VAC draw from the DC power supplies will be 1.67 A (max). Measurement of the actual AC power draw from the power supplies indicates that the draw is only 0.34 A (max) and 0.21 A (typical).

In addition, there will be a 2 A (max) draw at 115 VAC 60 Hz to power four temperature-controlled heaters, which will be on whenever wing power is on. Therefore, the total 115 VAC 60 Hz load will be less than 3.7 A. Actual measurements of the total 115 VAC power indicate that it is 2.1 A (max) in Standby mode and 2.4 A (max) in Operate mode. The typical values are 0.9 A and 1.3 A, respectively, when measured on the ground. These can be expected to approach the maximum values when the instrument cold-soaks

in flight and the heaters have a longer duty cycle. The maximum measured AC current is completely dominated by the heaters, which draw 2.0 A when on, since the DC power supplies use a maximum AC current of 0.34 A.

4.2.2 Cabin

Cabin power is limited to whatever power is needed to run the laptop computer which provides high-level control of the MTP. This power requirement is not known to us because we do not provide the laptop computer.

4.3 4.3 Wiring Used for MTP-H

All wires are from the RAF approved wiring list dated November 15, 2007. Per the RAF recommendation, MIL-W-22759 wire is used for all single conductor wire since it is approved by the FAA in Advisory Circular (AC) 43.13-1B Table 11-11 and 11-12, from any manufacturer, and does not need to be burn tested. The difference between Table 11-11 and 11-12 is that the former applies to “open wiring” and the latter to “protected wiring”. Open Wiring is defined as “Interconnecting wire [that] is used in point to point open harnesses, normally in the interior or pressurized fuselage, with each wire providing enough insulation to resist damage from handling and service exposure. Electrical wiring is often installed in aircraft without special enclosing means.” “Airborne wire that is used within equipment boxes, or has additional protection, such as an exterior jacket, conduit, tray, or other covering is known as protected wire.” The specifications for protected and open wiring are Mil-W-22759/11 and /16, respectively. They have the following properties:

Mil-W-22759/11

Insulation: Polytetrafluoroethylene (PTFE)
Conductor: Silver Plated Copper
Voltage Rating: 600 Volts
Temperature: - 55°C to + 200°C

Mil-W-22759/16

Insulation: Ethylene-Tetrafluoroethylene (ETFE)
Conductor: Tin Plated Copper
Voltage Rating: 600 Volts
Temperature: 150°C

For the MTP we have followed Mil-W-22759/11 since all the wires are protected.

4.3.1 115 VAC Wiring On Power Supply and Synthesizer Plate

Line M22579/11 20 AWG Black
Neutral M22579/11 20 AWG White
Ground M22579/11 20 AWG Green

4.3.2 Temperature Control bus: 120 VAC and 12 VDC

Wire: M22579/11 20 AWG
Thermal Cut-Out: Cantherm R20 60 C Open-On-Rise
Heaters: 4-Ohmite TCH-35, 220 Ohm in series/parallel on each assembly. Each heater circuit is fused at 2 A (AGC-2).

4.3.3 Main Wiring Harness

Connectors: Conec Industrial D-sub IDC for Flat Ribbon

Wire: Temp-Flex F2807S-050-55

4.3.4 DC and Signal Wiring in Sub-Assemblies

Unshielded: M22579/11 24 AWG

5 Mechanical Description

In the HIAPER MTP Design Package, this section provided different plan views of the HIAPER MTP, some including the DMT canister, which are not relevant for the HALO MTP. Those solid models will also be provided here in Section 5.2. We preface this section, however, with information relevant to the certification of the MTP front end against bird strikes. Mechanical certification of the HIAPER MTP was performed at NCAR/EOL/RAF by aeronautical engineer, Mark Lord. The HIAPER MTP Mechanical Certification document can be found in the **References**.

5.1 Certification Information

We have been requested to provide additional information for the front end of the HALO MTP. **Figures 5-1** through **5-3** show different details of the MTP mounted on the HALO carrier, which replaces the DMT canister (which the HIAPER MTP installed in).

HALO MTPH	8/4/2010		
Weight of Adapter Ring and Major Parts Forward of Ring			
	grams	lbs	Drawing number with dimensions
Interface Plate (Adapter Ring)	780	1.72	67708MTP-05
Base Plate	820	1.80	67708MTP-04
Base Plate Brackets(2)	108	0.24	67708MTP-06 and -07
Electronics Enclosure	400	0.88	67708MTP-11, -12, and -13
Motor	770	1.69	see Figure 3-6
Motor Mount	95	0.21	67708MTP-41
Target	450	0.99	see Section 3.1.4
Target Mount	135	0.30	67708MTP-33
Scan Mirror Assembly	423	0.93	see Section 3.1.5
Scan Chain & Sprockets	140	0.31	67708MTP-14 thru -19
Radiometer Plate	685	1.51	67708MTP-20
Radiometer Cover + Connectors	125	0.28	67708MTP-01, -02 and -03
Nose Block	25	0.06	67708MTP-09
Cable Harness	300	0.66	see Section 14 MTPH_Wiring, 5/5
Fairing	1600	3.52	67708MTP-43, -50 and -51
Total	6856	15.08	

Table 5-1. The weight in grams and pounds (lbs) of MTP components forward of the Adapter Ring/Interface Plate. The right-most column provides a reference to the MTP drawing on which the component dimensions can be found. These drawing are provided in Section 19, **MTP Mechanical Drawings**. Not all these drawings are large enough to be able to read actual dimensions. In that case, the free SolidWorks **eDrawings Viewer** should be used to determine dimensions. These drawings have been provided electronically.

Table 5-1 summarizes the weight of HALO MTP components forward of the Adapter Ring/Interface Plate. It also provides the drawing number on which the component can be found elsewhere in this document.

We have also been asked to provide specifications for the eight #8-32x0.62 socket-head screws which attach the Interface Plate to the Carrier Flange. They are NAS1352-08-10P as is shown in **Figure 5-3**, and the HIAPER MTP Mechanical Certification document referred to above. In addition we are asked to specify the four screws which mount the Fairing to the Interface Plate. These are shown in **Figure 5-1** and **5-2**, and the HIAPER MTP Mechanical Certification document. These four #10-32x0.72 flush head screws conform to MS24694-353. These screw specifications are certainly correct for the HIAPER MTP; however, **for the HALO MTP we used screws which we obtained from the JPL parts store.** We are told that the parts meet the NASM16995 standard, which means that the material is STEEL COMP 302 OR STEEL COMP 303 OR STEEL COMP 304 OR STEEL COMP 305 OR STEEL COMP 316 OVERALL. The NAS1532 standard means that the material is STEEL OVERALL. See:

<http://www.wbparts.com/rfq/5305-01-023-4764.html>

for more information. If there is concern about this difference the screws should be replaced by screws that meet the DLR certification requirements.

The HIAPER Mechanical Certification document discusses the strength of the MTP Fairing, and states that “The scanner cover is fabricated from seven (7) layers of fiberglass all at +/-45 degree orientation.” We contacted the manufacturer (Zivko Aeronautics, Inc.) for more detail and were told that there is 1 ply of LTA23NC/PM25 adhesive film, and 6 plies LTM22/GF0103 fiberglass prepreg cloth.

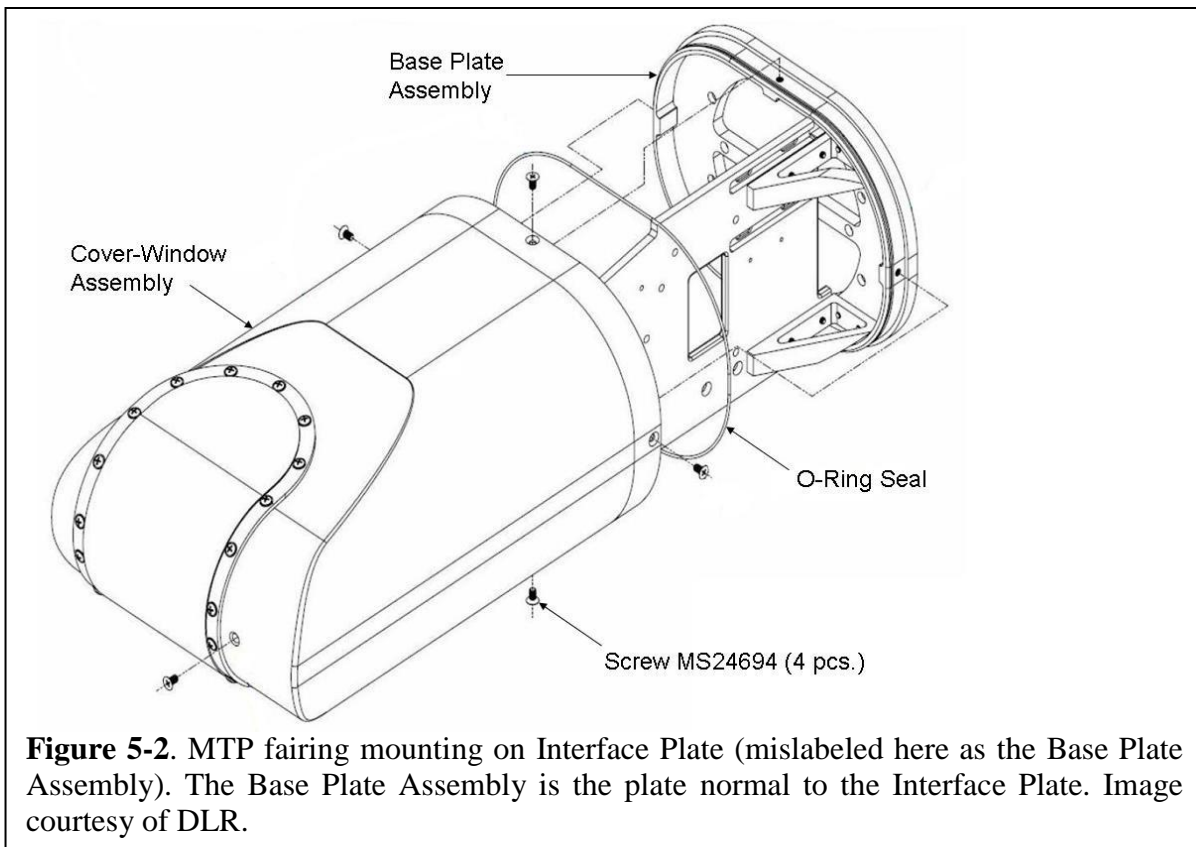
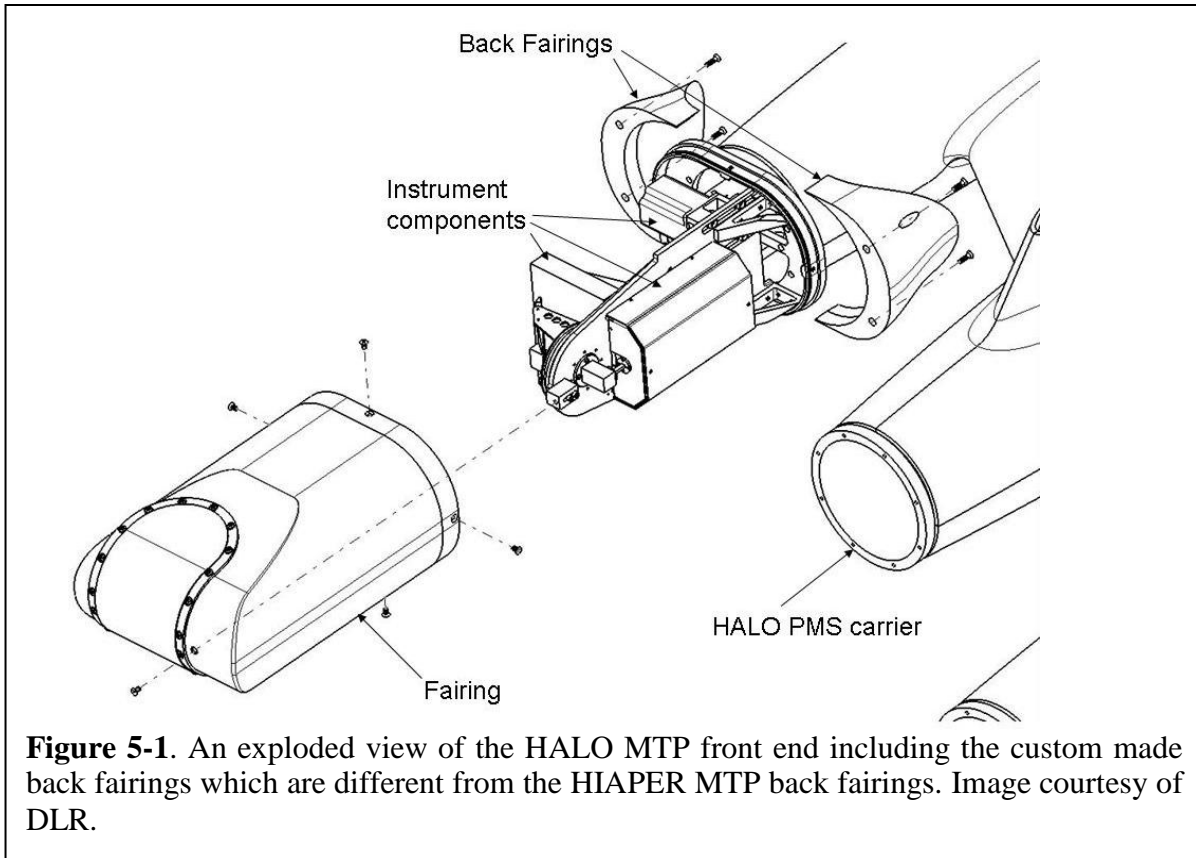

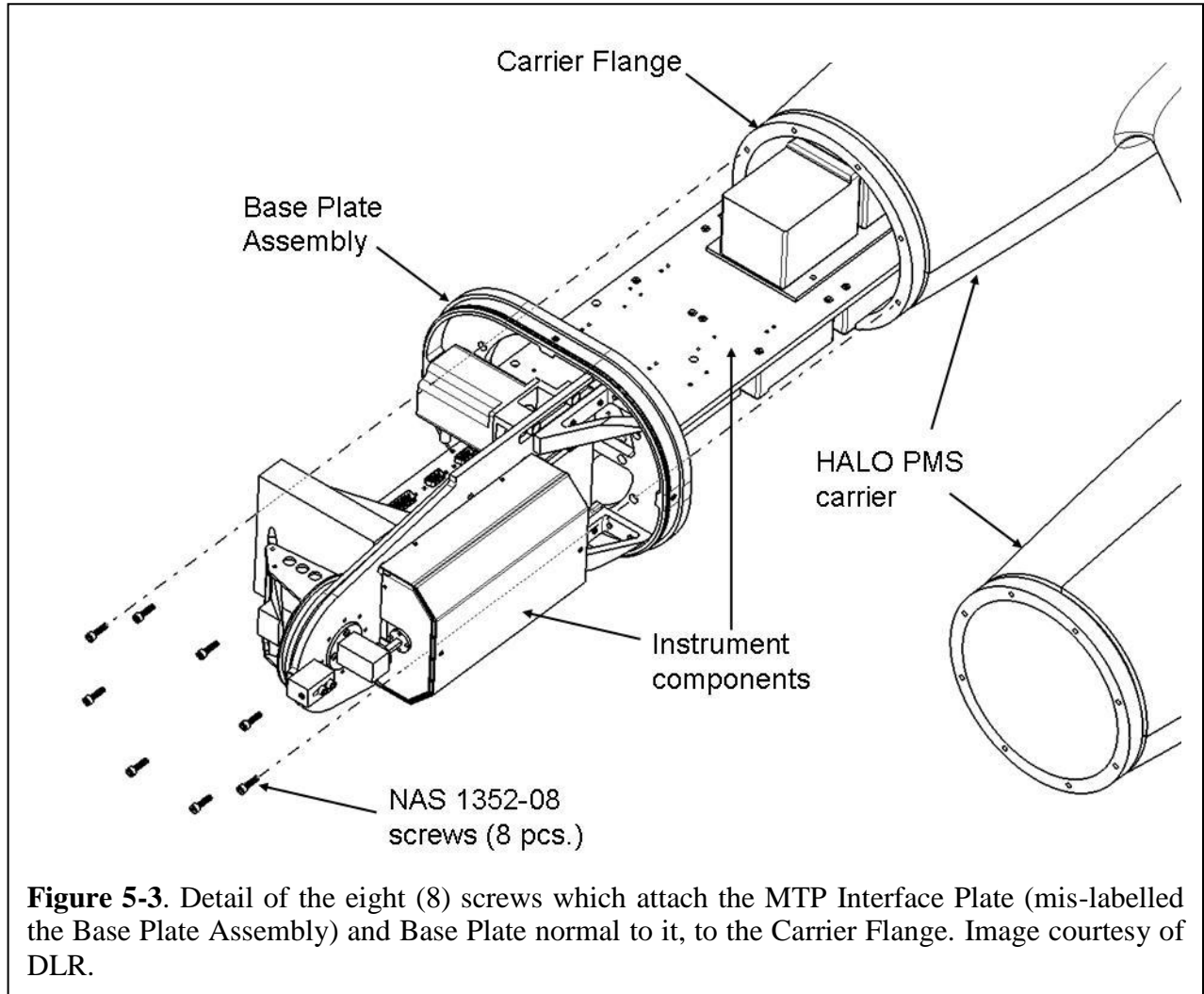
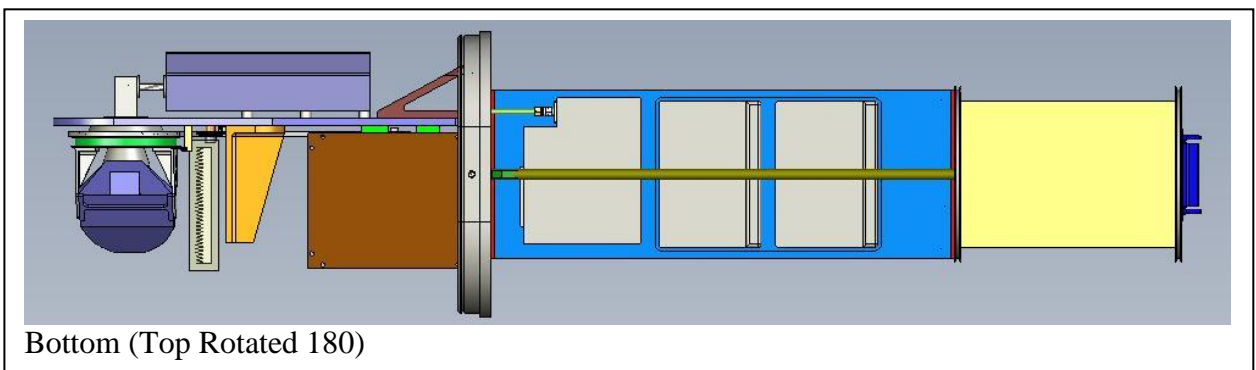
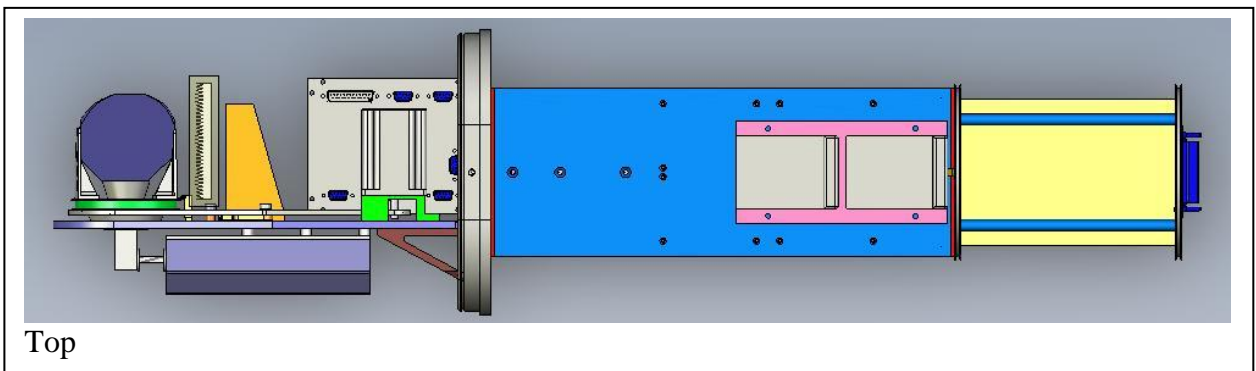
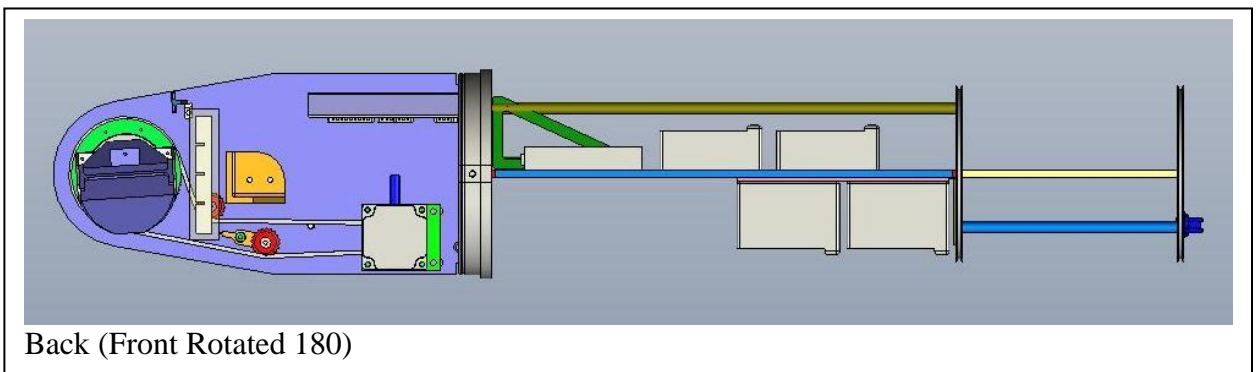
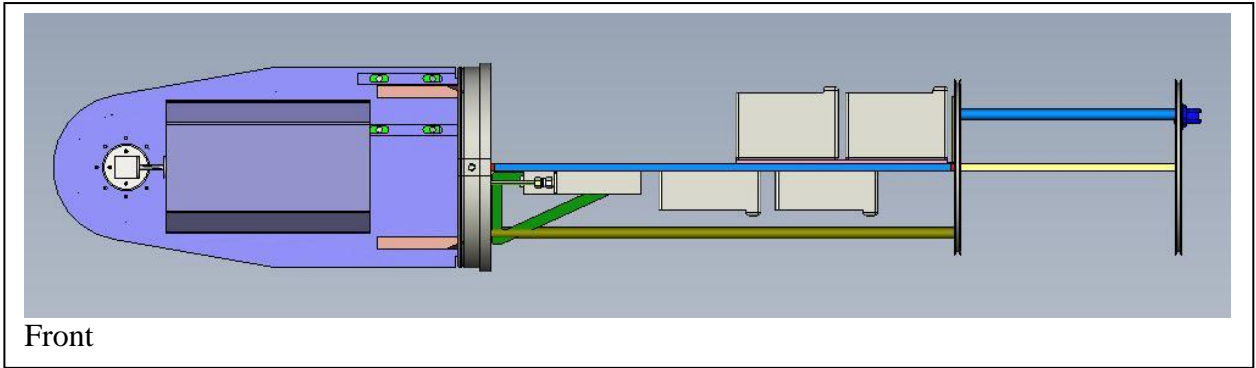

Figure 5-3. Detail of the eight (8) screws which attach the MTP Interface Plate (mis-labelled the Base Plate Assembly) and Base Plate normal to it, to the Carrier Flange. Image courtesy of DLR.

5.2 *HIAPER Wing Hardware*

Four views of the HIAPER MTP with the fairing and window removed are shown on the following page.

Fairing Removed



Transparent

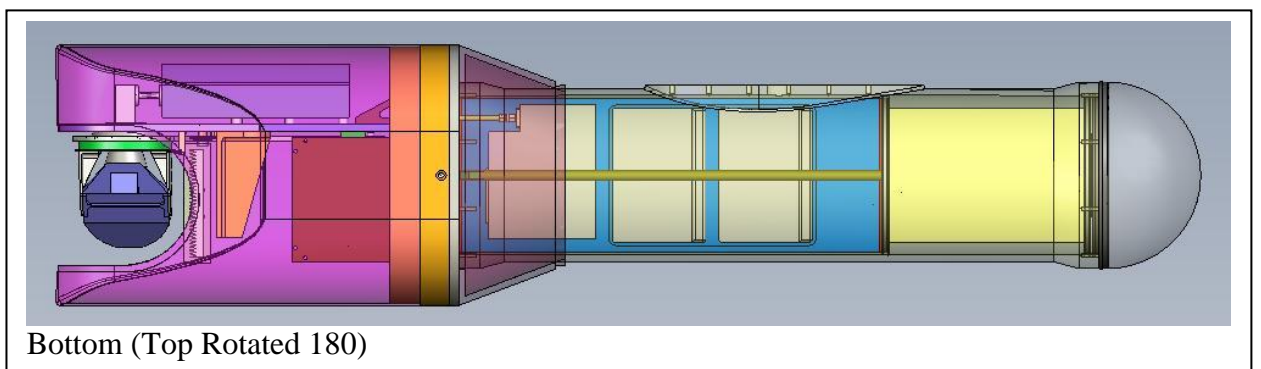
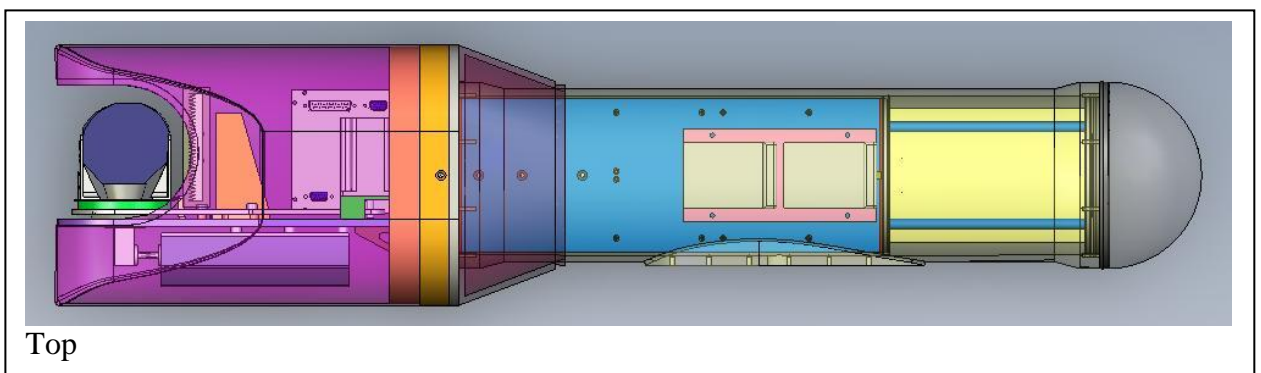
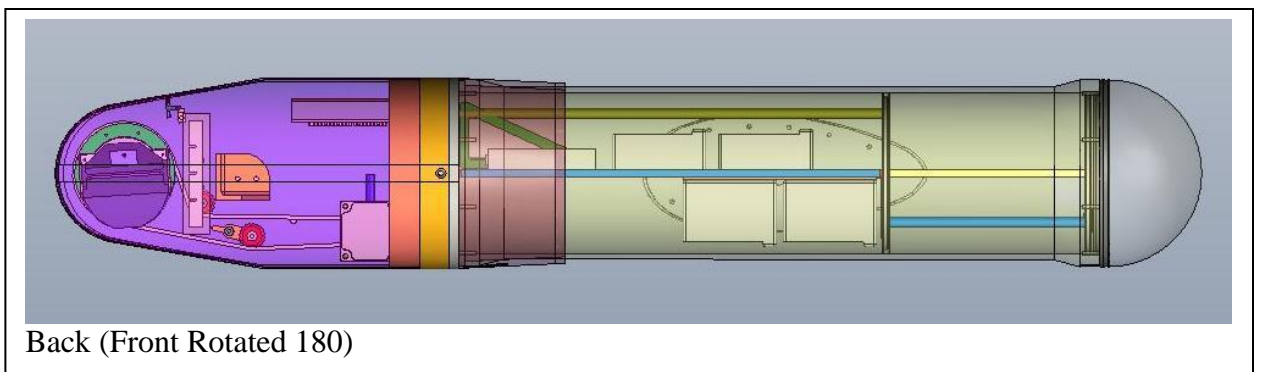
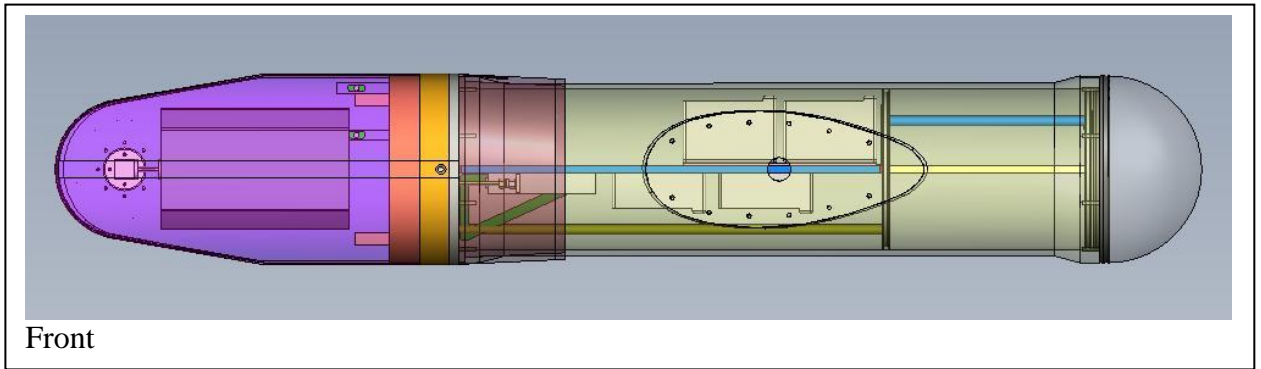

Solid

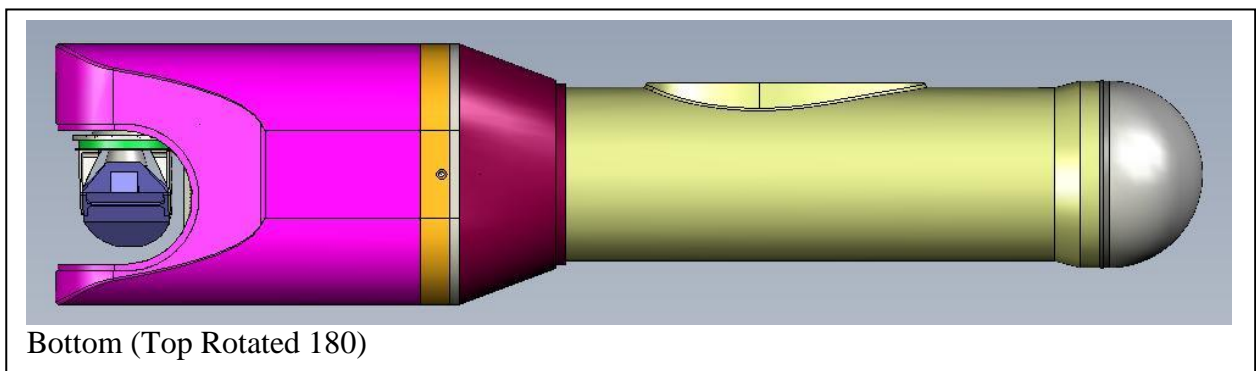
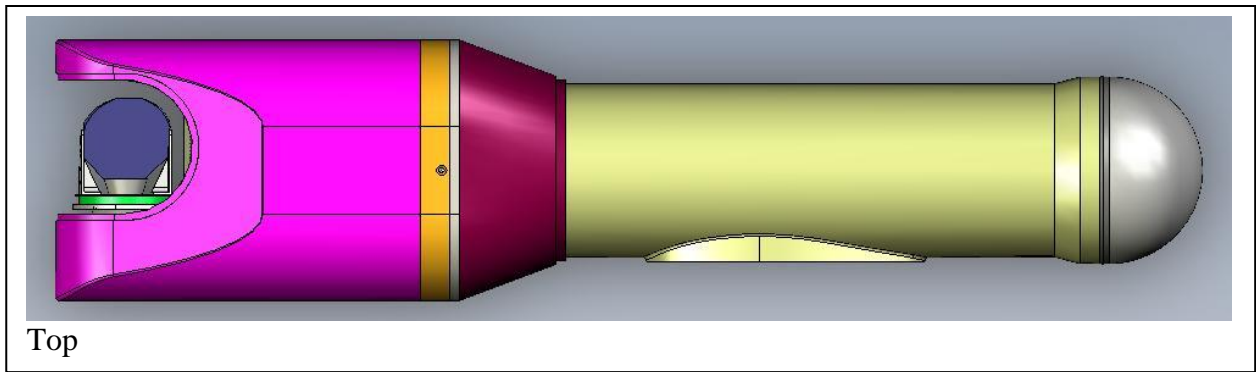
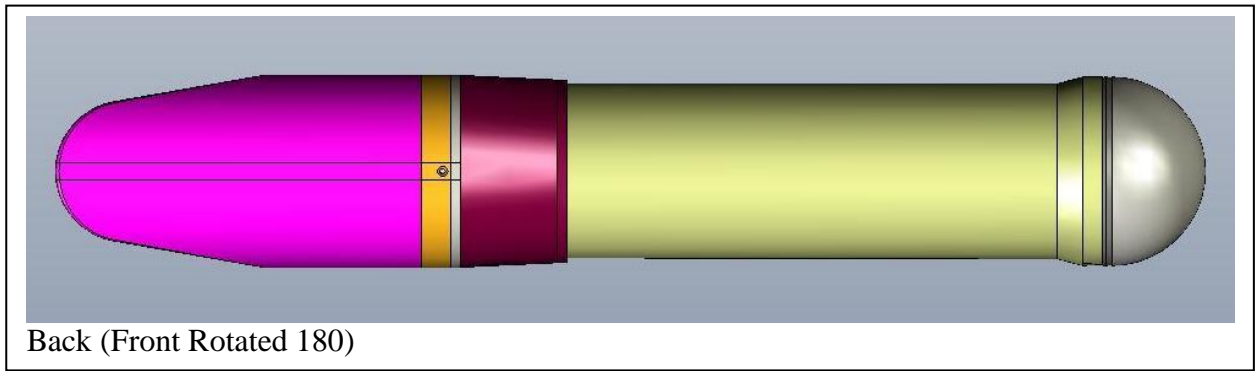
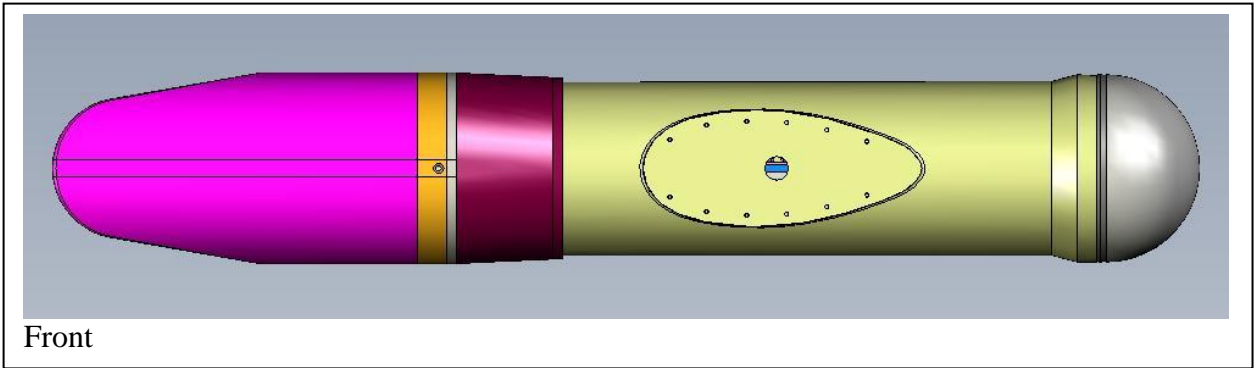

Nose

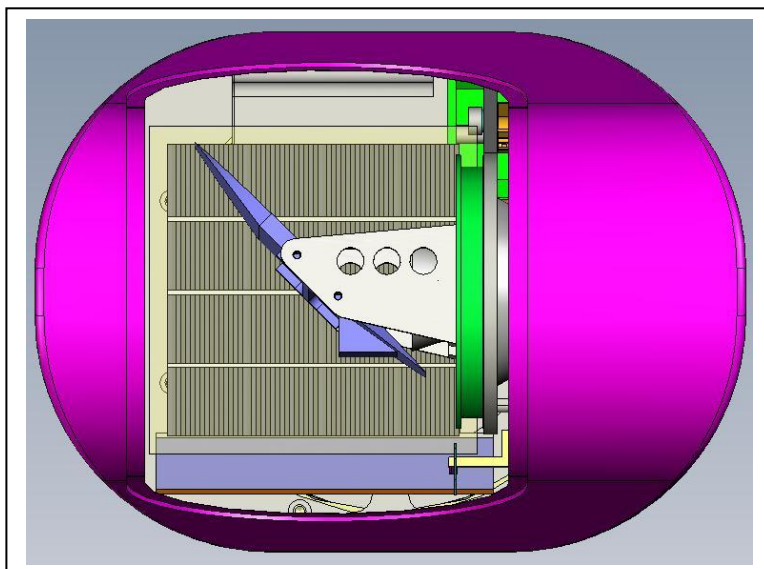
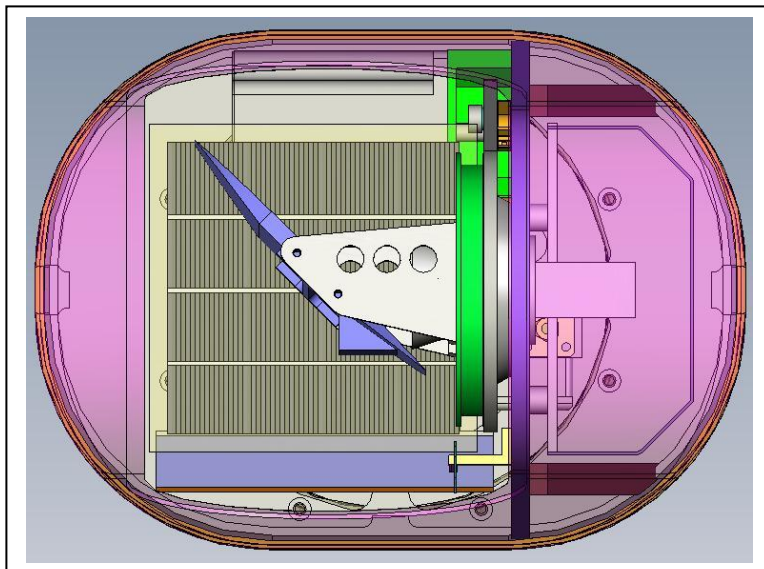
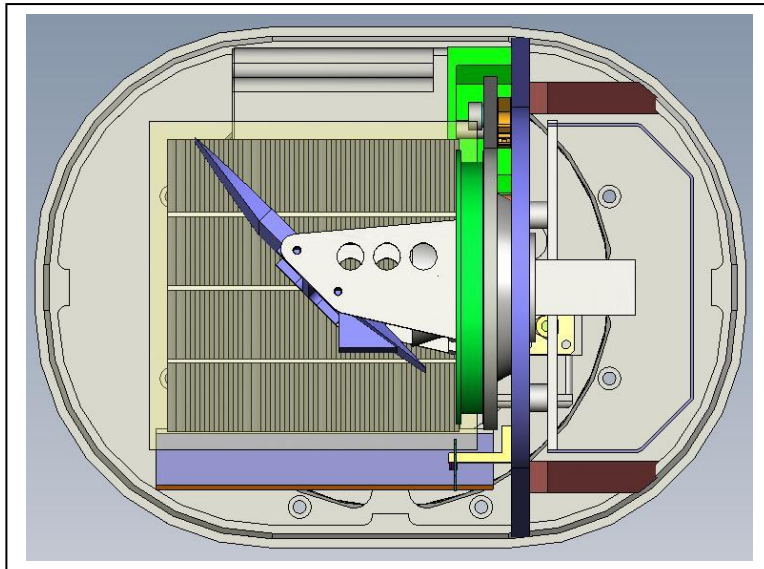

Tail

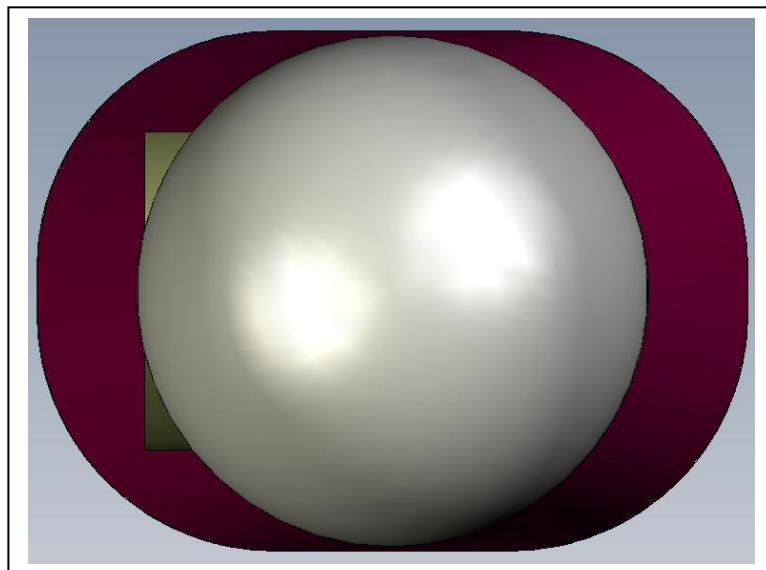
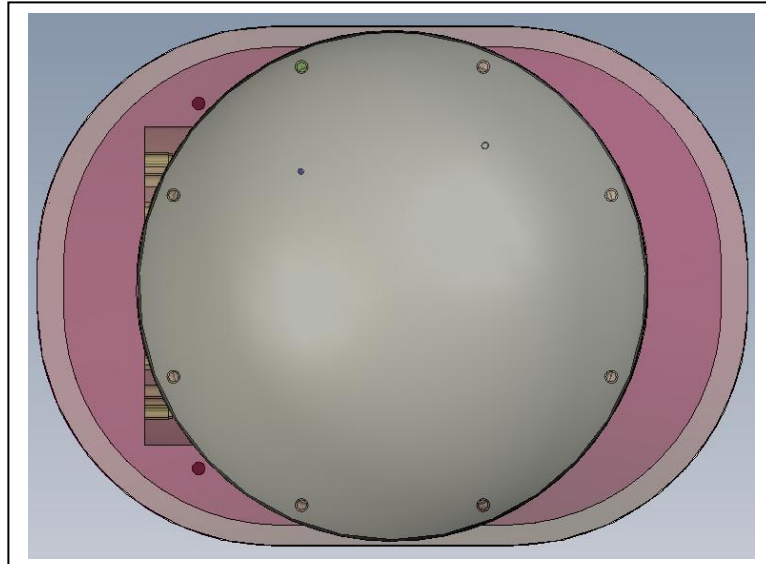
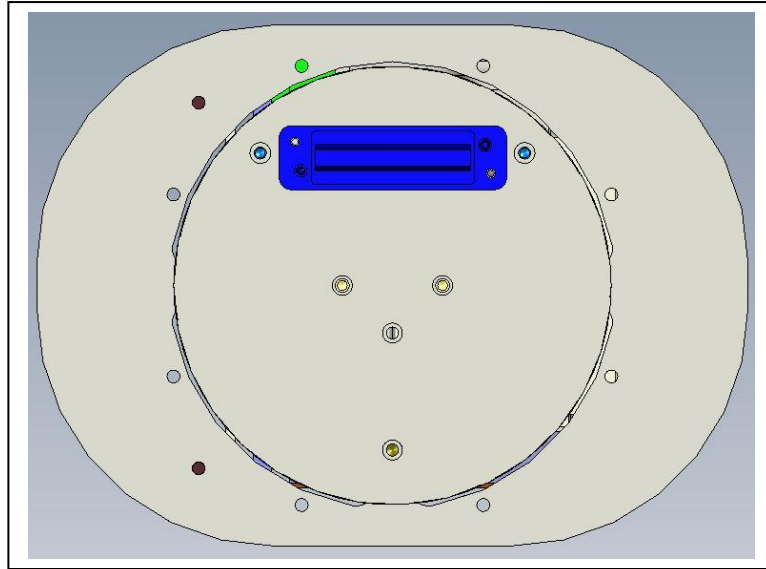

6 Software Description

The MTP software can be categorized into three broad categories:

- software that is used in the programmable integrated circuits (PICs) that are used in the instrument (the Controller Board has two and the Temperature Controller Boards have one),
- software that runs in the MTP Cabin Computer to control the MTP and collect data from it, and
- software that is used to perform retrievals and other data analysis-related steps.

These categories are described below.

6.1 PIC Software

There are three Microchip PICs used in the MTP-H. The Integration Timer and Counter PIC on the *Controller Board* uses native Microchip assembly language for programming. A listing of the assembly language code is provided in **Section 18**, and will also be provided electronically. The Control and IO PIC, also on the Controller Board, and the Temperature Controller Board PIC are both programmed using Hi-Tech C in MPLAB IDE, which compiles into native Microchip assembly code and is burned onto the Flash memory in the PIC. A C-language listing for the Control and IO PIC is given in **Section 19**, and for the Temperature Controller Board PIC in **Section 17**.

6.2 MCC Control Software

Visual Basic 6.0 software on the *MTP Cabin Computer* (MCC) is used to control the MTP in the canister and record data from it. This software will be provided electronically.

6.3 Data Analysis Software

Visual Basic 6.0 software is used for all the MTP data analysis software. It falls into five broad categories: the main retrieval program, a simulation program, several RAOB management programs, a program to calculate retrieval coefficients, and many utility programs. The main retrieval program is also used in the MCC to generate real time temperature profiles. All of the MTP data analysis software has already been provided to NCAR, and it is updated as revisions and upgrades are developed.

7 References

Brown, Shannon, Giovanni DeAmici, Alan Tanner, William Wilson, *CMIS Calibration Target Radome Measurements at 50 and 183 GHz*, JPL Internal Report, 2006.

De Amici, Giovanni, Ryan Layton, Shannon Brown, and David Kunkee, *Stabilization of the brightness temperature of a calibration warm load for space-borne microwave radiometers*, accepted by Transactions on Geoscience and Remote Sensing (TGARS), 2006.

Denning, R. F., S. L. Guidero, G. S. Parks and B. L. Gary, *Instrument Description of the Airborne Microwave Temperature Profiler*, J. Geophys. Res., 94, 16,757-16,765, 1989.

Gary, B. L., *An Airborne Remote Sensor for the Avoidance of Clear Air Turbulence*, AIAA Paper, AIAA-81-0297, 1981.

Gary, B. L., *Observational Results Using the Microwave Temperature Profiler During the Airborne Antarctic Ozone Experiment*, J. Geophys. Res. **94**, 11,223-11,231, 1989.

Interagency Working Group for Airborne Data and Telecommunications Systems (IWGADTS), <http://www.eol.ucar.edu/iwgadts>. Paper: http://www.eol.ucar.edu/raf/Software/iwgadts/33_ISRSE_IWGADTS.pdf

Lamb, James W., *Miscellaneous data on materials on millimetre and submillimetre optics*, International Journal of Infrared and Millimeter Waves, Vol. 17, Num. 12, pp. 1997-2034, December 1996.

<http://www.ovro.caltech.edu/~lamb/ALMA/Receivers/mmMaterialProperties2.pdf>

Lord, Mark, *Microwave Temperature Profiler (MTP) Assembly, NSF Gulfstream V Aircraft, SN 677*, Document No: 677-08-MTP-SA, Revision: IR, Date: March 13, 2008, National Center for Atmospheric Research, Research Aviation Facility, 10802 Airport Court, Broomfield, Colorado 80021.

Strand, O. N., and E. R. Westwater, *Statistical estimation of the numerical solution of a Fredholm integral equation of the first kind*, Journal of the ACM, 15(1):100-114, January 1968.

8 Appendices

9 Theory of MTP Measurements

In the main text we mention that the MTP measures the natural thermal emission from oxygen molecules in the Earth's atmosphere. A little more insight might help as it is not possible to measure a temperature profile using other molecules in the Earth's atmosphere. Molecular oxygen has some (almost unique) properties. First, molecular oxygen is a well-mixed gas in the atmosphere. Therefore, the amount of emission or absorption does not depend on geometric altitude, only frequency, pressure, temperature and to a small extent water vapor density. This could not be said, for example, for water vapor and other trace gases. Second, in order to measure a temperature profile, you want to observe at several frequencies with different absorption so that you can "see" different distances, and thus improve the information content of the measurements. (Measurements at several frequencies with the same absorption coefficient would only reduce the noise of the measurements but not improve the information content needed to make retrievals at larger distance from the airplane.) If molecular oxygen (O_2) had a simple diatomic-molecule rotational spectrum, like carbon monoxide (CO) for example, this would not be possible. For most diatomic molecules, the energy levels depend only on the rotational angular momentum quantum number (J) and the moment of inertia (I) of the molecule. The energy difference between energy levels increases as $2*(J+1)*B$, where B is the rotational constant for the molecule. (B is inversely proportional to the moment of inertia of the molecule.) Thus the $J=1-0$ transition has $2B$ units of energy; the $J=2-1$ transition, $4B$ units of energy; the $J=3-2$ transition, $6B$ units of energy and so on. So if the $J=1-0$ transition was at 60 GHz (near the center of the oxygen band), the $J=2-1$ transition would be at 120 GHz, the $J=3-2$ transition at 180 GHz, etc. If O_2 was like CO, this is how the rotational lines would progress, and several receivers would be needed to measure several lines. Fortunately, Molecular Orbital theory (correctly) predicts that molecular oxygen has two unpaired electrons, which makes it paramagnetic. This produces a much more complicated set of spectral lines, and therefore several lines with different absorption can be observed using a single receiver.

Not just the MTP, but also many satellite-borne microwave temperature sounders, take advantage of these properties of molecular oxygen, but there are important differences. Satellite sounders generally observe in the nadir at a number of frequencies that define a number of averaging kernels over which a temperature is retrieved. In addition to observing a number of frequencies, the MTP also has a scanning mirror, which moves from near-zenith to near-nadir in the flight direction. This allows the MTP to obtain very good vertical resolution near flight level (see below).

As shown in the top left of **Figure 9-1**, when the MTP scan mirror is pointed at a particular angle Θ above the horizon, it is basically integrating the emission from oxygen molecules along the line of sight. The emission is weighted quasi-exponentially $W(r)$ with range (r) because the emission further and further from the measurement location is absorbed by the intervening oxygen molecules. Now it is possible to show that in the case where the temperature changes linearly with altitude that the brightness temperature measured by the MTP is actually equal to the physical temperature at the e-folding distance R_a along the line of sight. (This assumes that the energy levels of the oxygen molecules are populated in thermodynamic equilibrium at the kinetic/physical

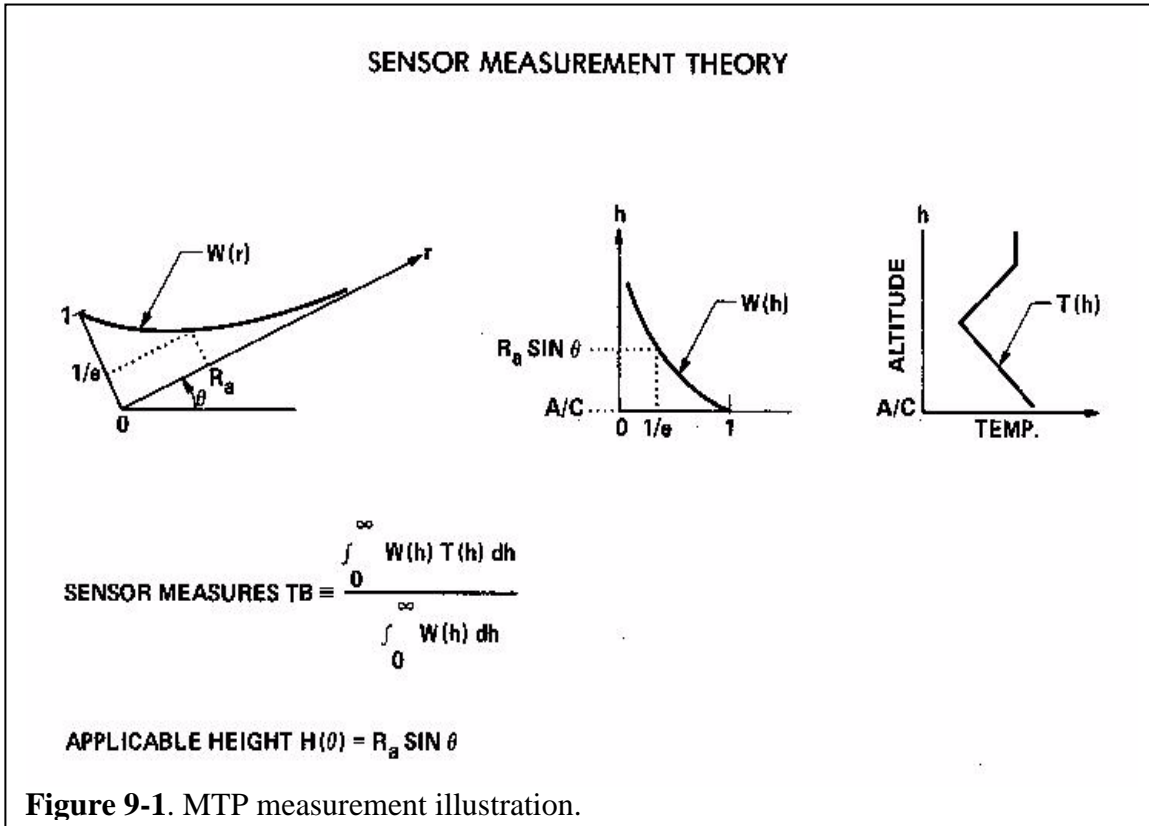

Figure 9-1. MTP measurement illustration.

temperature of the molecules, which they are.) The height above the aircraft corresponding to the e-folding distance is called the applicable height $H(\Theta) = R_a \sin(\Theta)$. Under the assumption of a constant lapse rate with altitude, measurements at a number of elevation angles could be used in this manner to construct a temperature profile. Note that when Θ is small the applicable height is also small. This is why the MTP can measure with very good vertical resolution near flight level. It should be noted however that the measurement angle is not the limiting factor here, because the MTP has a 7.5° FWHM beam-width. That's what determines the ultimate resolution and the Nyquist-sampling strategy. The reader should be aware that the vertical resolution of the MTP is elevation-angle, and therefore altitude, dependent. The horizontal resolution is also scan-angle/altitude dependent, and this is complicated by the fact that the aircraft is moving.

Of course the real atmosphere does not always have a linear lapse rate. Think of what would happen near the tropopause, for example, where there is a temperature inversion. As a result more powerful retrieval techniques need to be used. As mentioned in the main text, we use a statistical retrieval procedure with a Bayesian component. Many other retrieval techniques are possible such as physical retrievals or neural network retrievals. We have tried some of these and basically find that <5% improvements in accuracy are possible over a simple statistical retrieval (without Bayesian help). Since we have a Bayesian component to our retrievals, our approach is likely as good as what is possible.

10 Receiver Architecture Considerations

Figure 10-1 shows the microwave absorption spectrum for molecular oxygen from the ground (green) to 20 km (purple). For HIAPER we will be predominantly interested in the absorption from 10 km (blue) to 15 km (red). Notice that on the ground (green) that the pressure broadening of molecular oxygen is so strong the individual rotational lines are not apparent. However, even at 10 km the lines are starting to distinguish themselves.

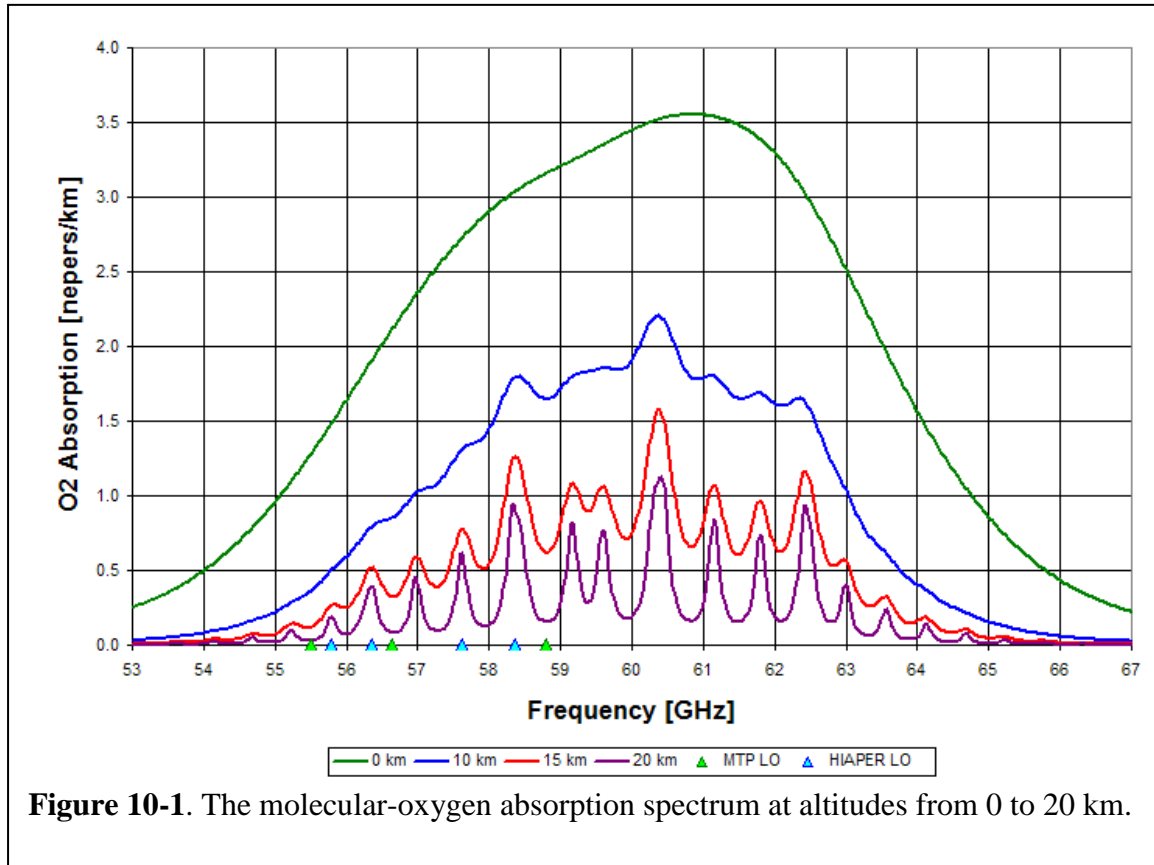

This is an important consideration for airborne MTPs.

The MTP instruments employ double side band (DSB) biased mixers. That is, they mix the received broadband radio frequency (RF) signal with a nearly monochromatic local oscillator (LO) signal to form an intermediate frequency (IF) signal from both the upper (USB) and lower (LSB) side bands (frequencies $RF \pm LO$). The green triangles at the bottom of the figure show the local oscillator (LO) frequencies for the three existing MTP instruments. Notice that the LO is located between pairs of lines so that the DSB receiver can receive signal from both side bands. The advantage of having two sidebands is a root two improvement in signal to noise. However, since both side bands don't have exactly the same absorption coefficient, the received signals in the two sidebands are not coming from exactly the same distance. This means that if there is temperature structure in the direction being viewed, there will be temperature smearing in the observables, and hence

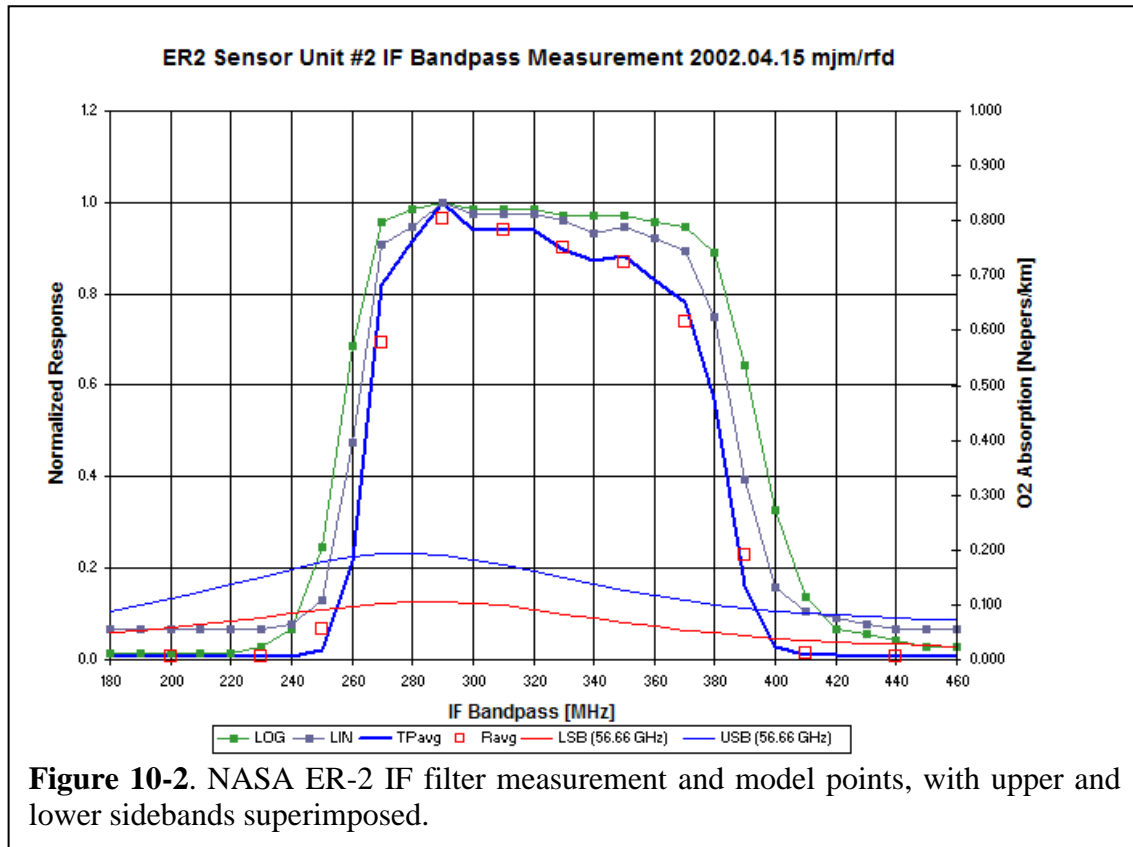

de-graded retrievals. Another (not so obvious) issue is that the three pairs of lines don't have exactly the same frequency separation. Since the IF filter after the mixer is centered at a fixed frequency (320 MHz with 100 MHz bandwidth), this means that the IF filter will not be equally well matched to all three pairs of lines. This is illustrated in **Figure 10-2**. The thin blue line is the RF USB and the thin red line is the RF LSB superimposed on the IF filter shape (heavy blue line) for an LO frequency of 56.66 GHz. Not only is the absorption not the same for both sidebands, but they don't peak at the same IF frequency and they are not centered on the IF at 320 MHz. They peak closer to 280 MHz. For another pair of lines the match is better, but there is always some compromise because the line pairs are not equally spaced in frequency.

The issue of matching the IF filter to the upper and lower sidebands is obviously more important at high altitudes where line shape becomes more important. An way to avoid this problem all together is to use a single side band receiver and center the LO on lines of interest. This is an approach that we seriously considered for the HIAPER MTP. As shown in **Figure 10-3** a 3-7 GHz IF is used with individual filters for each of 4 observing frequencies. This has the advantages of observing all frequencies simultaneously and of being able to use a single fixed-frequency LO source (which would be cheaper and simpler than using a frequency synthesizer). On the down side, a high pass filter must be included in front of the mixer to avoid unwanted signals in the lower side band. Two bad things happen: you are only receiving half the signal because you are detecting only one sideband, and the high-pass filter adds additional insertion loss, which degrades the noise figure of the receiver.

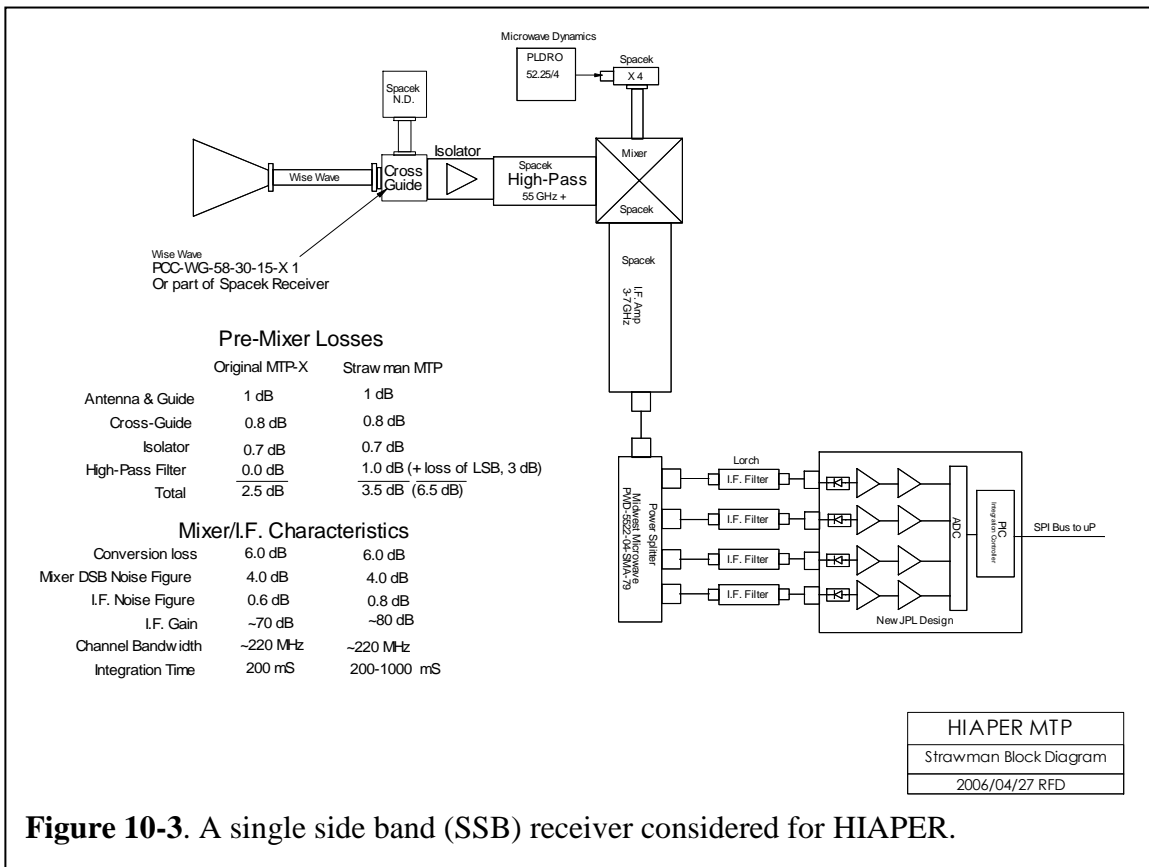
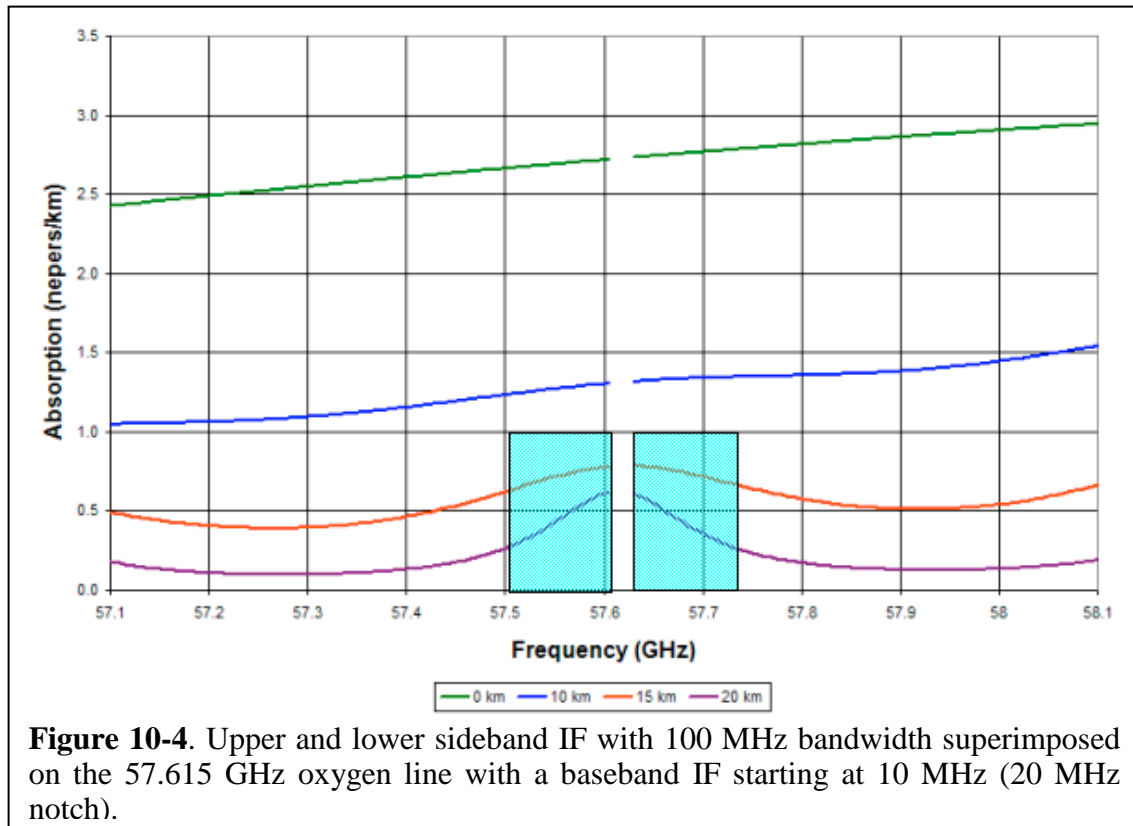

Figure 10-3. A single side band (SSB) receiver considered for HIAPER.

To overcome the degraded noise figure, we considered putting an RF amplifier in front of the mixer. This has its own set of issues. Low noise InP RF amplifiers unfortunately do not have good 1/f noise performance. To get around this problem, a Dicke switch would have to be included in front of the amplifier. That has issues too. First you are only observing the signal half of the time, and second you are subtracting two signals; the net result is that a Dicke switched receiver is only half as sensitive as an unswitched receiver. After all of these considerations, we concluded that our current receiver configuration was the best choice (with one small change).

There is a trade off between mixer noise figure and IF frequency coverage. One way to improve the current upper and lower sideband mismatch issue is to put the IF at baseband with the LO centered on the lines of interest. This starts the IF as close to DC as possible with the LSB measuring the lower half of the line, and the USB measuring the upper half of the line. When we bought our current mixers, the noise figure of baseband mixers was not nearly as good as at 320 MHz (a frequency dictated by line pair separation). Today it is possible to get good mixer noise figure performance with a baseband IF starting at 10 MHz. That is what we are going to do. **Figure 10-4** shows an ideal rectangular IF filter superimposed on the 57.615 GHz oxygen line. The filter has a bandwidth of 100 MHz in this figure. The actual bandwidth is important because it is one of the parameters determining the receiver's sensitivity. Below 10 km **Figure 10-4** shows the absorption



slowly increasing with altitude so much larger bandwidths could be used. The rms variation in the absorption at 10 km, expressed as a percentage is 1% for a 100 MHz wide IF, and only 2% for a 200 MHz wide IF. This means that over the IF pass band there is not very much variation in absorption and there will not be much temperature smearing in the retrievals. However, by 15 km (close to HIAPERs ceiling) these percentages increase to 5% and 13% respectively, which is starting to become significant. Since the IF filter is easily replaced and not expensive (~\$200), it might be important to exchange the filter depending on the planned flight profile.

11 Investigation of Target Cover Materials

In order to calculate the gain of a microwave receiver it is necessary to have at least two reference temperatures. These could be obtained by using hot and cold (or ambient) targets, or as in the case of all MTPs built to date, an ambient reference target and the outside air temperature (OAT). Reference targets are usually made from pyramidal-shaped microwave-opaque materials that have a very large emissivity (as close to unity as possible); they are generally mounted on a metal substrate into which are embedded one or more precision platinum resistive thermal devices (RTDs) to measure the physical temperature of the target. For these targets to be useful (i.e., accurate) it is necessary that there are neither axial nor planar temperature gradients across the target. This is particularly challenging in the space environment where solar insolation can easily produce thermal gradients if the target is not thermally insulated. However, even in the more protected thermal environment of the MTP fairing, temperature gradients in the reference target can still be an issue. To provide a benign thermal environment, the MTP reference target has to date been surrounded by a one-quarter inch thick layer of Styrofoam – a Dow Chemical Company expanded polystyrene (EPS) foam. An important property of an insulating material (in addition to having very small thermal conductivity) is that it not absorb microwave energy as this would effectively reduce the emissivity of the target and lead to a disagreement between the physical temperature (measured by the RTD) and the brightness temperature (measured by the radiometer). (This relationship can be affected by many more issues than will be discussed here.) Using one-quarter inch thick Styrofoam results in a thermal time constant of about one-half hour. Until recently this was the best material available: it was essentially microwave transparent, or equivalently, it had a dielectric constant (or relative permittivity, ϵ_r - see below) whose imaginary part was very small.

Before proceeding it will be useful to write down a few equations relating the dielectric constant to other common physical parameters, as the relationship between them will be useful in identifying material other than Styrofoam that might be useful as microwave-transparent target-insulating materials. The reason for needing to look for an alternative material to Styrofoam is that Styrofoam is flammable, and it was suggested during the PDR that, even though the MTP target uses a very small amount of Styrofoam (4" x 4" x 0.25") an effort should be made to find a less flammable material.

So we move on to a discussion of the relationship between common terms used to describe the microwave properties of material such as the refractive index, the dielectric constant, and the permittivity. First off, we note that the complex refractive index, m :

$$m = \sqrt{\epsilon_r \cdot \mu_r}$$

is the square root of the product of the relative permittivity (ϵ_r) and the relative permeability (μ_r), where the term *relative* means relative to free space. The relative permittivity is just another name for the dielectric constant, and is given by:

$$\epsilon_r = \frac{\epsilon}{\epsilon_0} = \epsilon_{re} + i\epsilon_{im}$$

where ϵ is the permittivity, ϵ_0 is the permittivity of free space, and ϵ_{re} and ϵ_{im} are the real and imaginary parts of the relative permittivity or dielectric constant. A similar expression can be written for the relative permeability. However, if a material is non-magnetic, the relative permeability is unity, and the complex refractive index is simply

$$m = \sqrt{\epsilon_r}$$

the square root of the relative permittivity:

Now the microwave energy loss, or absorption, in any material is simply proportional to the imaginary part ϵ_{im} of the dielectric constant (as well as the electric field strength squared and the frequency). Therefore, to evaluate different insulators for the reference/calibration target, we need to know the real and imaginary parts of the dielectric constant of any potential material.

Sometimes microwave engineers use the loss tangent, $\tan(\delta)$, instead of ϵ_{im} to represent the absorption. In terms of the loss tangent, ϵ_{im} can be written: $\epsilon_{im} = \epsilon_{re} \tan(\delta)$.

Finally, in terms of the complex refractive index, $m = n + i k$, where n and k are the real and imaginary parts, it is easy to show that $\epsilon_{re} = n^2 - k^2$ and $\epsilon_{im} = 2nk$. Armed with this knowledge we can scour the literature looking for complex refractive index, complex permittivity, complex dielectric constant, and loss tangent information to determine which materials will work best for the reference target window.

A comprehensive list of the microwave and submillimeter wave properties of materials was published in 1996 (Lamb). In the decade since then, many new (and better) microwave materials have been developed. In particular, colleagues at JPL have been very involved in testing these materials for both spaceborne (De Amici et al. 2006) and airborne (Brown et al., 2005) platforms. These recent tests show that one material stands out amongst all others for use in insulating microwave calibration targets. This material is Plastazote LD15, a low-density polyethylene (LDPE) foam made by a British company, Zotefoams PLC. The JPL tests showed that Plastazote LD15 had a value for ϵ_{im} of $4.5 \cdot 10^{-6} \pm 5.0 \cdot 10^{-6}$ at 50 GHz (and only 50% worse at 183 GHz). As is clear in Figure C-1, this makes Plastazote LD15 nearly an order of magnitude less absorbing than any other known material. In fact it is so transparent that the value of the imaginary part of the relative permittivity (dielectric constant) is smaller than the accuracy of the measurement. It should be little surprising that virtually every group that uses microwave calibration targets uses this material.

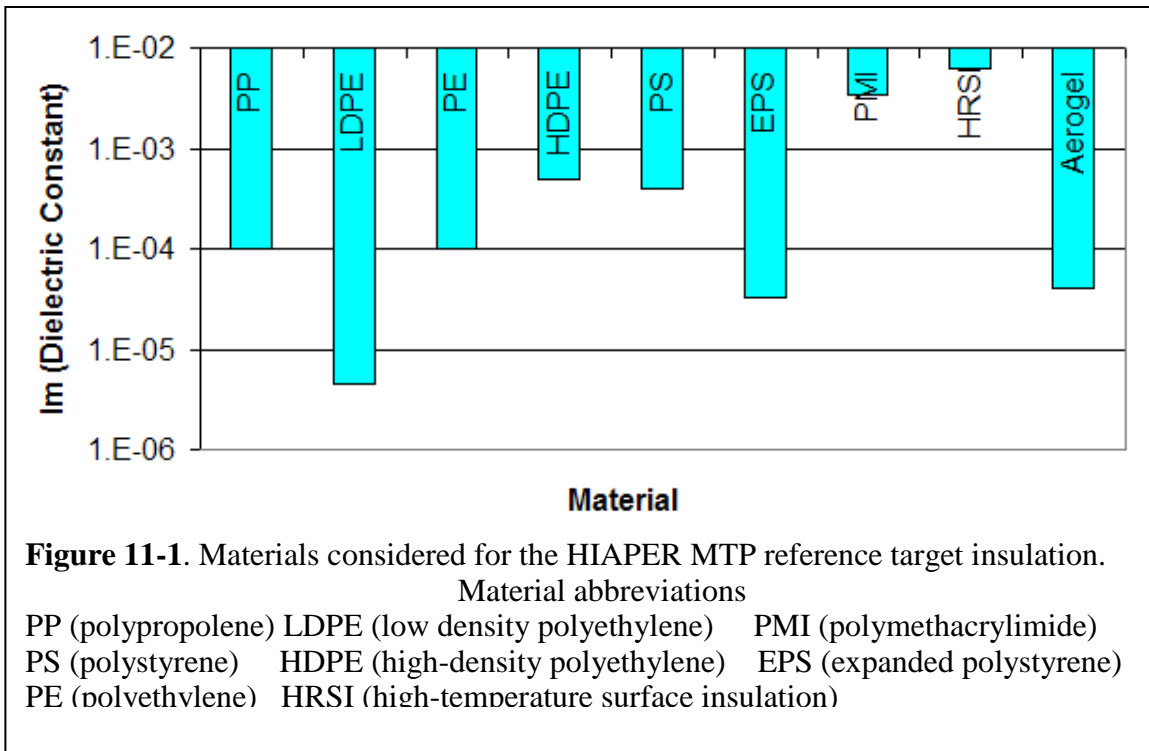

We contacted Zotefoam shortly after the PDR to discuss other fire retardant foams that they make so that we could test them. We were promised four additional samples to test, but repeated phone calls have not been returned. Obviously they realize that we only need a small quantity and are not interested in pursuing the matter.

One material suggested at the PDR for use on the MTP target (because it has acceptable flammability characteristics and is used by RAF) was ROHACELL -- a polymethacryimide (PMI) foam made by Rohm GmbH. As can be seen in **Figure 11-1**, the imaginary part of its dielectric constant is the second worst of the nine materials considered.

Before we were aware of ROHACELL's properties we ran tests in our laboratory to compare it to Styrofoam. We set up an MTP to look at a 90 K hot target and adjusted the gain so that the analysis software indicated 90 K. We then inserted the ROHACELL foam sample and noted that the temperature dropped to 72 K! We then inserted a similar thickness of Styrofoam and saw that there was a <0.2 K temperature change.

ROHACELL has terrible microwave electrical properties. In hind site this could have been predicted. Although its dielectric constant is excellent (1.03, low-density foams are mostly air), it has a large loss tangent (0.003) – nearly three orders of magnitude poorer than Plastazote LD15! The properties are from the Rohm web site:
<http://www.rohacell.com/en/performanceplastics.html?content=/en/performanceplastics/rohacell>.

Space Shuttle tiles (HRSI) have been suggested in the past as an insulator, and as can be seen in **Figure 11-1**, it is the poorest of the materials considered. JPL makes aerogels for various space probes and we considered it as an option. Its imaginary part of the dielectric constant is slightly worse than Styrofoam, and it is very expensive, absorbs water vapor, and requires special mounting. Being silicon based however, it does not burn and is an extremely good insulator.

To summarize, it is clear that Plastazote LD15 is by far the best material to cover the reference target. We could find no literature on the flammability of this Zotefoam, but we were told by Zotefoams PLC that it is comparable to Styrofoam. So to address the flammability issue, we would use it only on the front face of the target. We did use it initially for the front face of the HIAPER MTP target. However, Plastazote LD15 is not a rigid material and had shrinkage issues with changes in altitude (and temperature). As a result the front face of the target now uses Styrofoam, as do all of our existing MTP targets. All other surfaces surrounding the target were covered with ROHACELL which is certified for aircraft use and also has a slightly lower thermal conductivity (0.031 W/mK) than Plastazote LD15 (0.039 W/mK). Both of these material are slightly more conductive than Styrofoam (0.025 W/mK).

12 MTP Power and Status Panel Drawings

As discussed in Sections 1.3 and 3.2, there are differences between the HALO and HIAPER MTPs. The HIAPER MTP is controlled by a rack-mounted computer in the cabin, and power is provided to this computer via the Power and Status Panel, which also displays instrument power status and has a switch to turn the instrument on. (see **Figure 3-11**). Connections from the Power and Status Panel to the instrument are via copper wires

The HALO MTP is controlled by a PC-104 computer behind the instrument, and control of the instrument is done using Ethernet UDP packets sent from any laptop in the cabin with appropriate software loaded.

Because of this change a Power and Status Panel was not built for the HALO MTP. However, it may be useful to do this at some point so that the instrument can be operated in the laboratory. In this section we provide drawings for the Power and Status Panel wiring, and the cable harness between the power and status panel and the Amphenol connector at the back of the MTP.

HALO MTP Design Package
JPL/Caltech PROPRIETARY —Not for Public Release or Redistribution

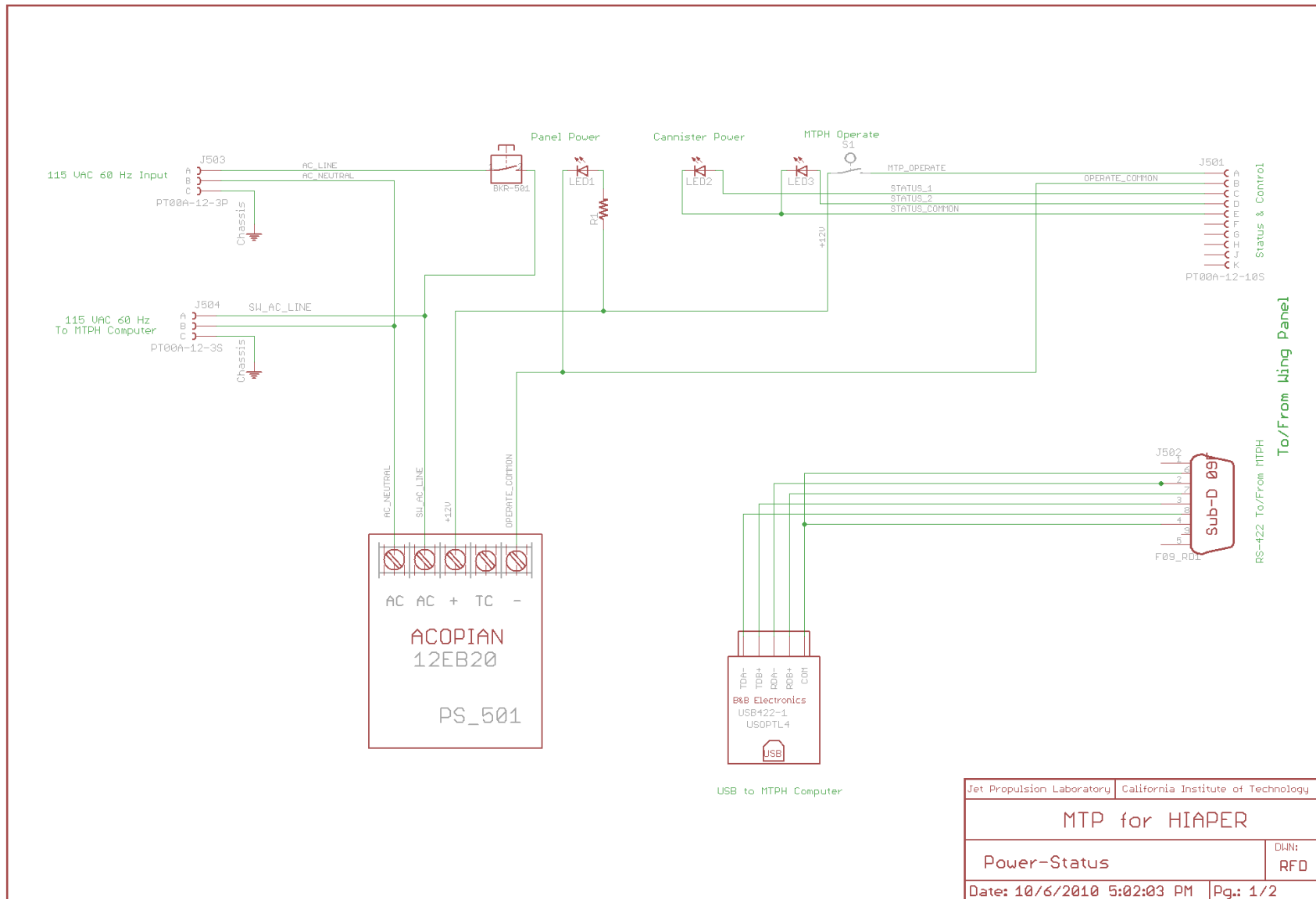

Jet Propulsion Laboratory	California Institute of Technology
MTP for HIAPER	
Power-Status	DI-N: RFD
Date: 10/6/2010 5:02:03 PM	Pg.: 1/2

HALO MTP Design Package
 JPL/Caltech PROPRIETARY —Not for Public Release or Redistribution

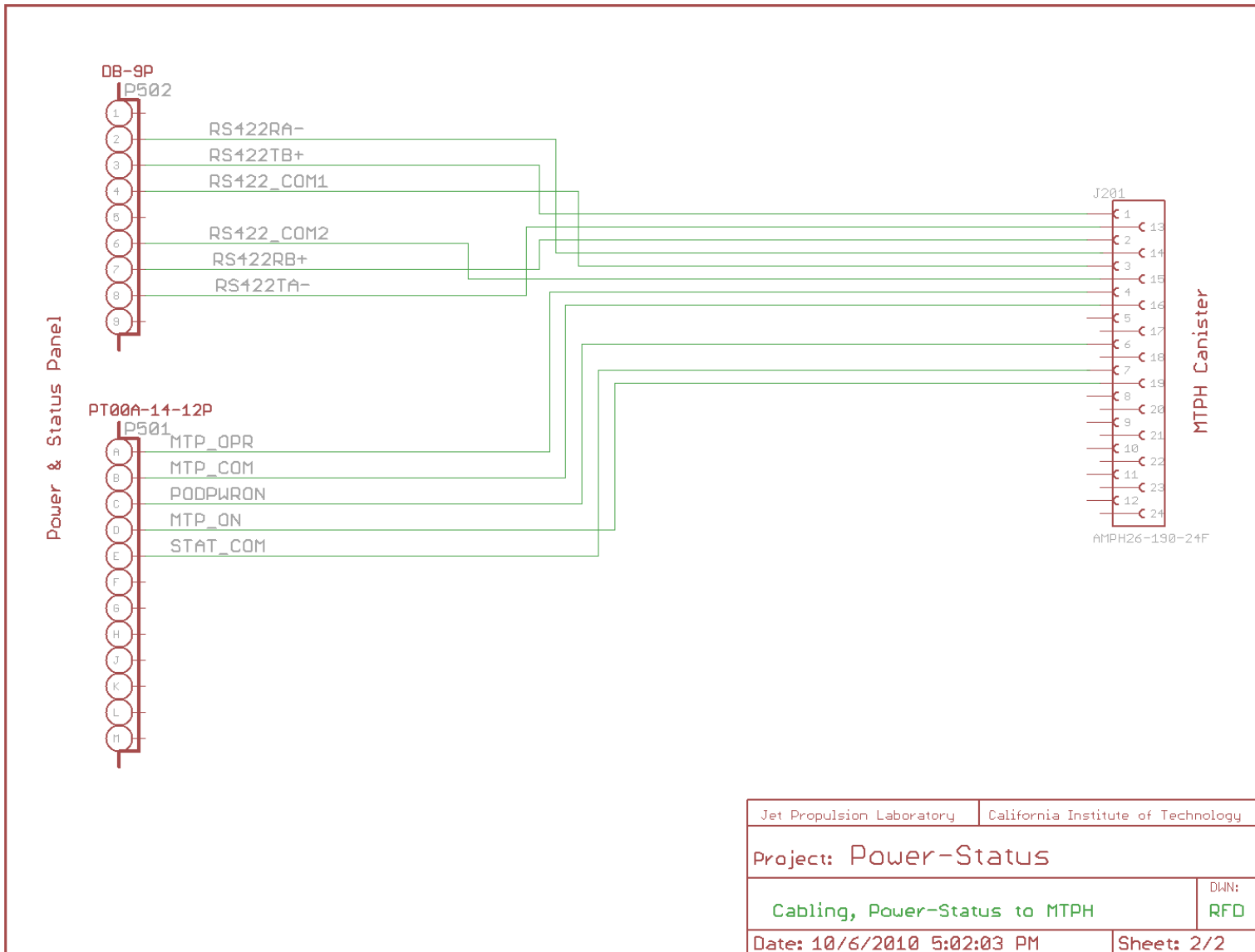

13 Temperature Control Circuits – Small_TC

Four assemblies in the MTP-H canister are temperature-controlled, either for temperature stability during a measurement, or to reduce condensation after cold-soaking at altitude. The four controllers (see **Figure 12-1**) are implemented in PIC16F675 flash micro-controllers on small PCBs mounted on or near the temperature-controlled assembly. A schematic drawing of the temperature controller board is shown in **Figure 12-2**.

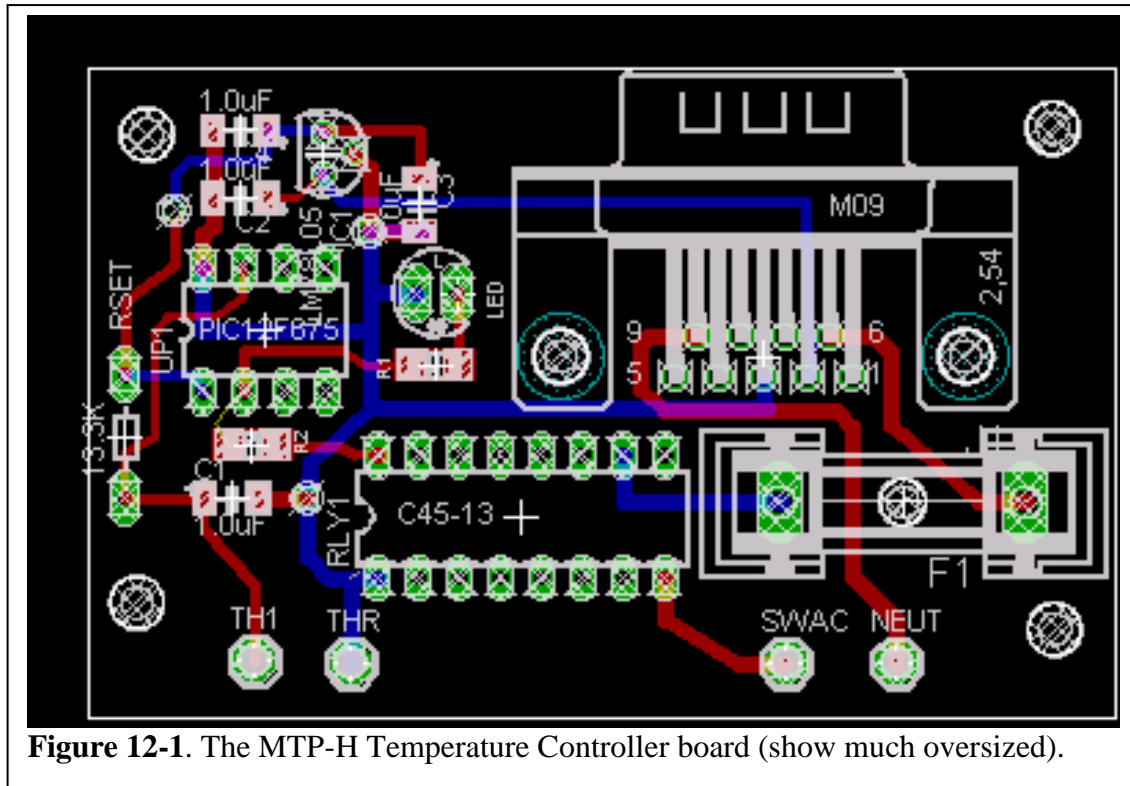

Figure 12-1. The MTP-H Temperature Controller board (show much oversized).

The control temperature is set by selecting a resistor that equals the resistance of the control thermistor (44008) at the desired set point. Typically, all the controllers will operate at about 40 C using a set point resistor of 16.2 K. The micro-controller drives a zero-crossing solid state relay -- a Teledyne C45-11, which switches 120 VAC to a string of four 220 ohm, 35W resistors in series-parallel configuration, producing a maximum heating capacity of about 65W for each heating circuit. The resistors are attached to the parts that they are heating by screws and thermally conducting compound.

The control program pulse-width modulates the relay at about a 2-Hz rate, and the zero-crossing relays switch the power near the zero-crossing of the AC waveform, to minimize switching noise. The temperature control system will operate with power line frequencies from 47 to 440 Hz.

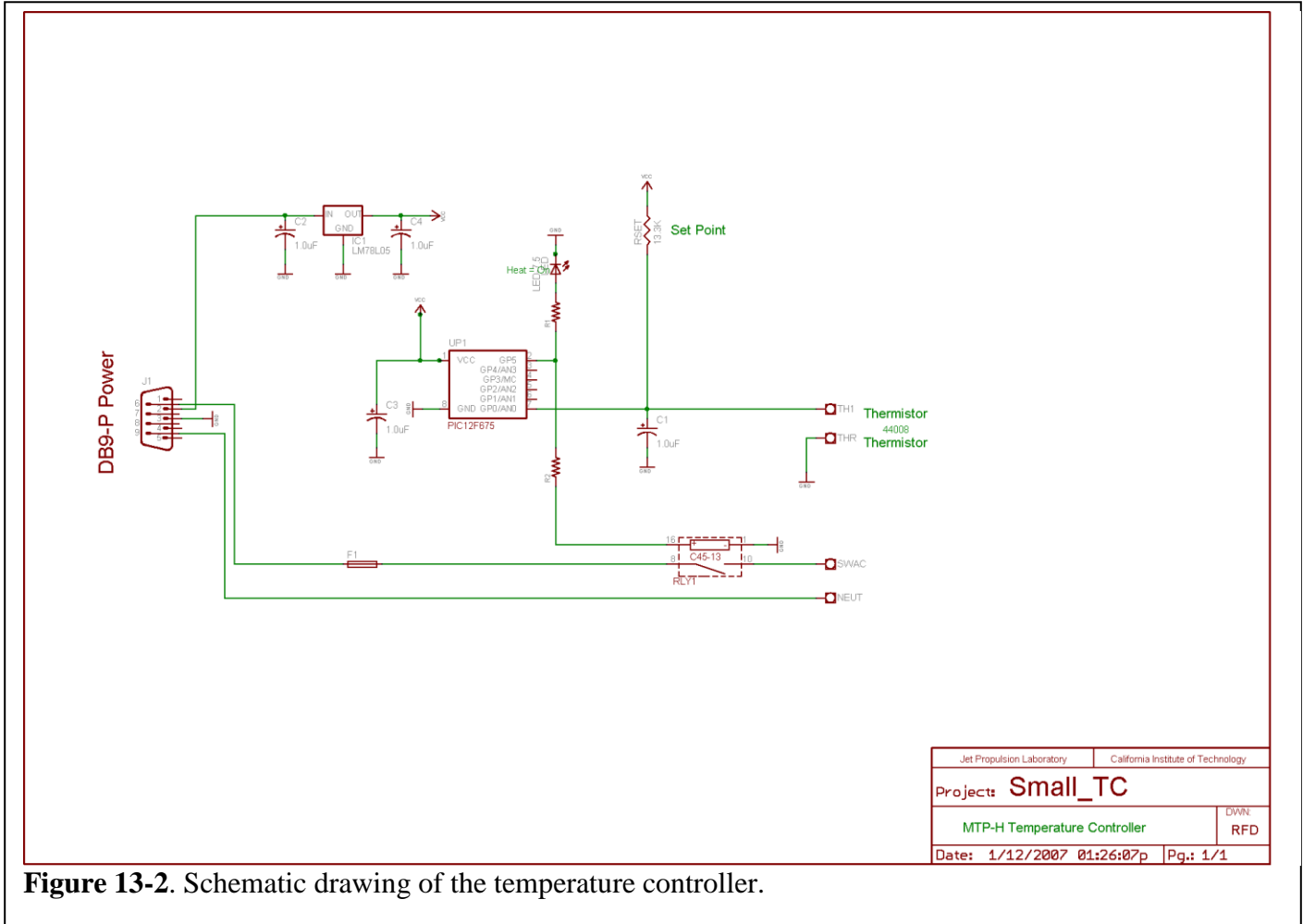

Figure 13-2. Schematic drawing of the temperature controller.

14 The MTP-H Controller Board Drawings

14.1 Sheet 1 - Overall architecture

The MTP for HIAPER is comprised of two major systems: the *MTP Cabin Computer* (MCC), and the MTP itself in a DMT-style canister. The MCC controls the MTP by sending commands to, and receiving data from, the *MTP-H Controller Board* in the canister over an RS-422 full-duplex serial bus.

The schematic drawings and printed circuit design were created using EAGLE 4.16. Sheet 1 of the *Controller Board* schematics is a block diagram showing how the various functions have been divided into logical subsystems on separate sheets. Each sheet has a manageable number of input and output lines, which makes it easy to see how the circuits work.

The *MTP-H Controller Board* consists of a combination of flash-programmed micro-controllers and data acquisition integrated circuits along with analog components. While the internal workings of the controller is quite complex, it can be treated as a ‘black box’ that interprets a small number of high-level commands and returns a correspondingly small set of data types.

For example, there is a command to read all the engineering ADC channels, which is an “M” followed by a carriage return. The response is a string of ASCII characters starting with “m” containing 16 channels of ADC data. Similarly, there are commands to read the status word, to start an integration cycle, move the scan system, and so forth.

Because of their “Flash-based” memory, the micro-controllers on the MTP-H Controller PCB are “in-circuit programmable,” meaning that by connecting a programmer to a small header on the PCB, the program in any of the micro-controllers may be replaced without removing them.

14.2 Sheet 2 - PIC Control & IO

A pair of 75176 differential transceivers, U1 & U2, convert between the RS-422 received and transmitted signals to and from the *MTP Cabin Computer* and the TTL levels used in UC1, a Microchip PIC16F876 flash-based micro-controller. UC1 acts as the gateway to the various circuits in the controller that perform the control/data acquisition functions via the Serial Peripheral Bus (SPI).

While the SPI bus handles almost all of the data traffic on the *Controller Board*, certain time-critical events (such as the ITG_BSY line that indicates whether the Integration Counter is busy or done), are read directly by UC1 on an I/O port to avoid delay in transmission on the SPI bus. For similar reasons, other lines controlled directly by UC1 turn on/off the Noise Diode, or flash an LED, for instance.

The SPI bus is organized as three lines (SDO, SDI, and SCLK) that are common to all peripheral devices, and several “Chip Selects” (CS0-9). Only one CS line is active at a time to select to which circuit the communication is directed.

MTPH controller Chip Select (CS) assignments:

- CS0: Integrator (UC2)
- CS1: Engineering Mux (ADC1)
- CS2: Engineering Mux (ADC2)
- CS3: Platinum RTD (ADC3)
- CS4: Platinum RTD MUX (SW1, SW2, SW3)
- CS5: Accelerometer Processor (UC3)
- CS6: Frequency Synthesizer (CTI SLS-1403, Off-board)
- CS7: Stepper Motor (UART1, Lin Engineering Silverpak 23CE off-board))
- CS8: Auxiliary UART (UART2)
- CS9: Spare CS

The control program in the PIC16F876 is called MTPH_Control.C and is described in Section X.

14.3 Sheet 3 - VFC and Integration Counter

The basic data produced by the MTP-H is a DC voltage proportional to the brightness temperature in front of the antenna. This voltage is converted into a pulse train whose frequency is proportional to the input signal by VFC1, an Analog Devices AD654. IA2 and OP3A provide for gain and offset adjustments during the initial setup of the MTP.

This pulse train, in turn, is counted for a known time, typically 200 mS by UC2, a Microchip 16F88 micro-controller, programmed to do the communications, timing and counting functions that perform the integration. It also signals via the ITG_BSY line when an integration is in progress and then answers a request to send the resulting values back to UC1 for transmission to the *MTP Cabin Computer*.

The integration time is controlled by a command on the SPI bus to UC2, which sets values from 1 to 256 increments of 20ms each, or from 20ms to 5.12 s. The value chosen is determined by a trade-off between receiver noise figure, receiver 1/f noise, and the time it takes to complete one scan cycle.

The integration program in the PIC16F88 is called “F88_integ_IRQ.ASM” and is listed in Section X.

14.4 Sheet 4 - Engineering Mux and ADCs

Sixteen (16) channels of engineering analog-to-digital conversion are provided by ADC1 and ADC2, both MAX186 low-power serial 8-channel analog-to-digital converters. Certain of these voltages require a scaling and/or polarity change to fit into the ADC range of 0 to +4.096V. In the case of measuring engineering temperatures by thermistor, a resistor to the reference voltage VTREF is used to provide bias. Typically, this resistor has a value near the thermistor resistance at the expected operating temperature of the device being monitored, so that mid-scale on the ADC represents the normal operating point. In practice, these resistors are set to a “typical” mid-scale value of 34.8 K, which corresponds to a temperature of +22 C. Thermistors are highly non-linear (actually exponential), so a linearization algorithm is used in the data analysis to produce the corresponding temperature value.

The MAX186's generate an internal reference voltage, which is accessible externally. The reference from ADC2 is buffered by OP3B and used for the thermistor bias mentioned previously.

14.5 Sheet 5 - Platinum Multiplexer and ADCs

Radiometric measurements are generally made by measuring the difference in radiometer output between a known “Reference” and an unknown temperature such as, in the case of the MTP, the air temperature. This comparison cancels out most of the variability in the

receiver itself, and simplifies several independent variables down to a single parameter: the physical temperature of the reference, which can be directly measured. Conversely, this means that the accuracy of the radiometric observation literally hinges on the determination of this one parameter.

All physical temperatures in the MTPH, which are used in the radiometric calculations, are determined from platinum Resistance Temperature Devices (RTDs), which provide excellent long-term stability. One of the penalties of the platinum sensors, however, is a low resistance (500 ohms at 0 C for the ones used here), which requires a relatively high measurement current (about 1 mA) and causes vulnerability to resistance in the leads and connectors (1 ohm ~ 0.5C).

In the MTP-H, a more-or-less standard 4-wire technique is used to remove the sensitivity to conductor resistance, and an internal calibration method borrowed from space-flight designs provides very high confidence levels, as well as a way to monitor the changes in the circuits without having to do frequent calibrations.

The circuitry used to make these measurements is comprised of:

The current source, which generates a voltage across the selected RTD or calibration resistor, comprised of OP1A, OP1B, and OP2A.

The current multiplexer (SW3, a MAX349 8-channel switch), which sends the current source to one of the six RTDs, or two calibration resistors.

The differential voltage multiplexer (SW1 and SW2, both MAX349s), which sample the voltage across the selected resistor or RTD and send it to:

An instrumentation amplifier (IA1, an Analog Devices AD620), which converts the differential voltage from the resistor or RTD to a single-ended input for:

A 12-bit A-to-D Converter (a MAX1272), which makes the A/D conversion and sends it to the controller (UC1).

The overall gain of the measurement circuit can be set with the gain resistor RG, on IA1, and the scale offset is set by the resistors associated with OP2B.

By use of this 4-wire circuit, resistance of 100 ohms or more in any or all conductors to the RTD can be tolerated without causing measurable error.

14.6 Sheet 6 - Stepper and Synthesizer Communications

The local oscillator frequency synthesizer -- a CTI SLS-1403 -- is tuned by sending the desired channel number directly to it over the SPI bus at CS6.

The stepper motor -- a Lin Engineering SilverPak 23CE -- has an intelligent controller built in, and needs only high-level commands to be sent to it on an RS-485 half-duplex

(sending and receiving at separate times) bus. A MAX3100 UART and a 75176 transceiver convert the commands and responses to and from the SPI bus using CS7.

Another UART/Transceiver circuit provides a second RS-485 bus for future expansion, at SPI address CS8.

14.7 Sheet 7 - Accelerometer

An accelerometer measuring aircraft vertical acceleration has traditionally been included in MTP designs as a means of studying the relation between the shape of the temperature profile and air turbulence. An MMA1270D MEMS accelerometer converts the acceleration to a voltage which is sent to the engineering mux.

More refined acceleration monitoring may be added later by the use of UC3, a PIC16F88 microcontroller, addressed on the SPI bus as CS5.

14.8 Sheet 8 - Power Distribution

All DC power used on the *Controller Board* comes in on J106 and passes through simple capacitive filters before distribution. Two voltage regulators drop the +/- 15 V to +/- 8 V for use in the RTD measurement circuit on **Sheet 5**. R/C decoupling circuits prevent cross-coupling through the power supply between several op-amps on the board.

HALO MTP Design Package
 JPL/Caltech PROPRIETARY —Not for Public Release or Redistribution

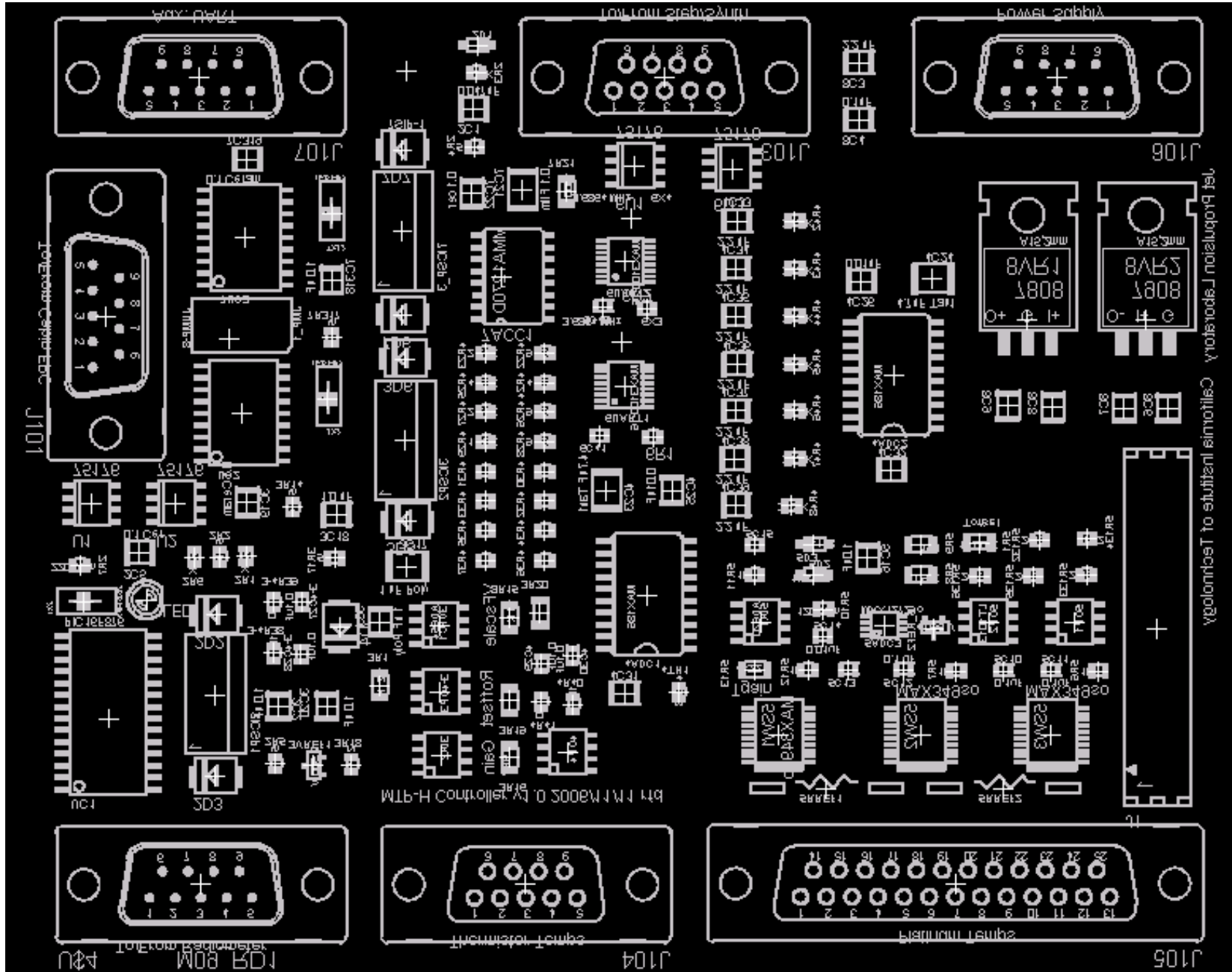

HALO MTP Design Package
 JPL/Caltech PROPRIETARY —Not for Public Release or Redistribution

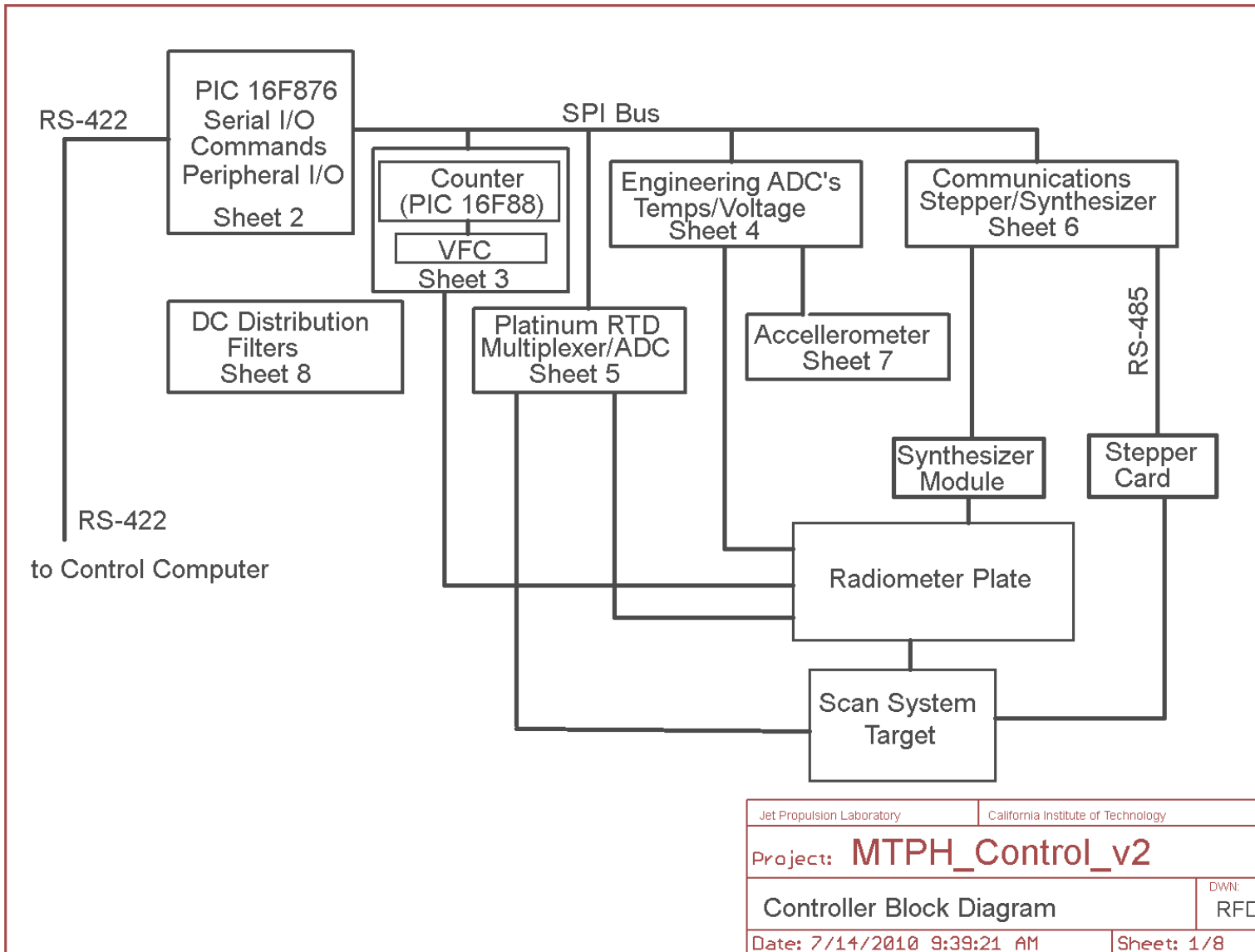

HALO MTP Design Package
JPL/Caltech PROPRIETARY —Not for Public Release or Redistribution

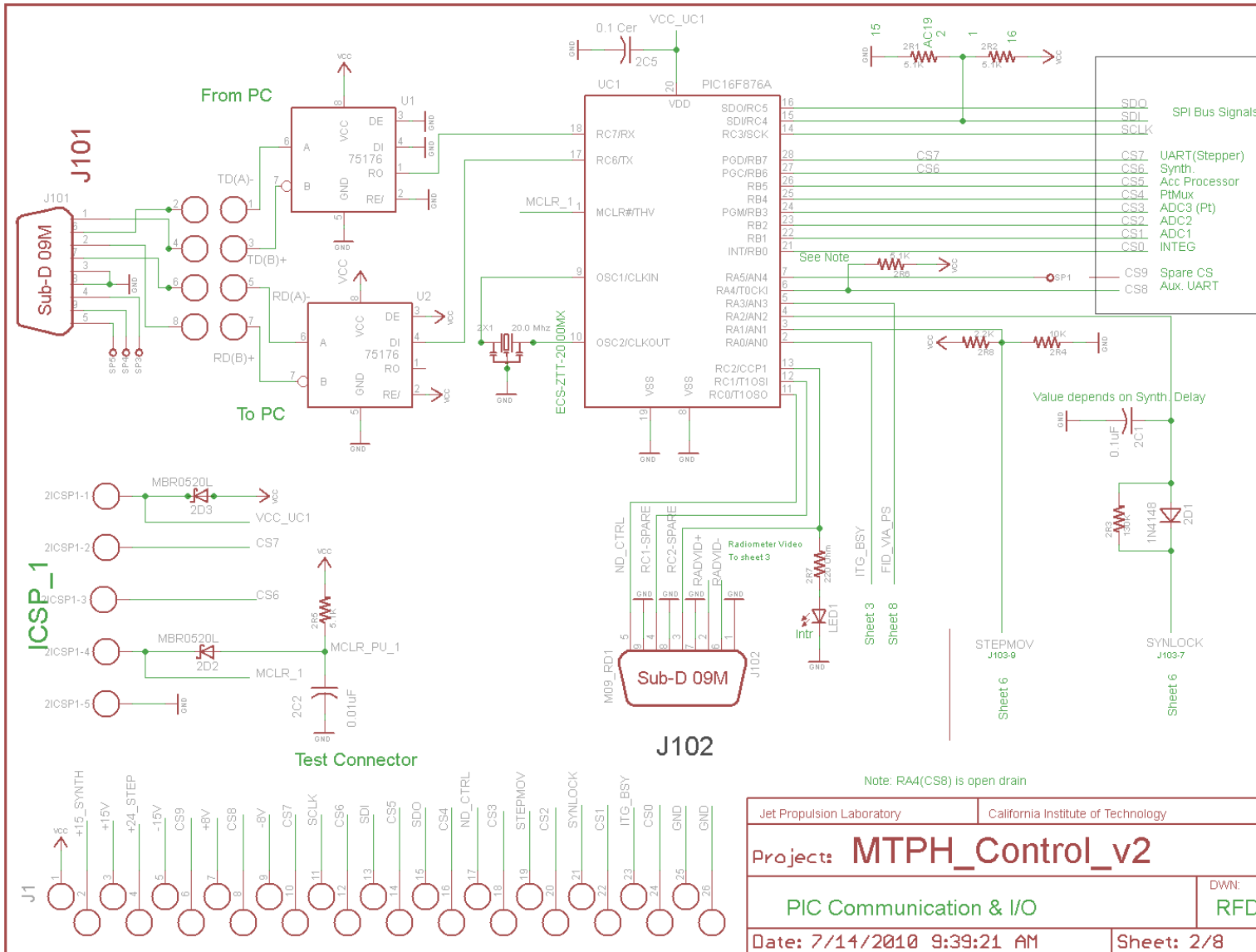

HALO MTP Design Package
 JPL/Caltech PROPRIETARY —Not for Public Release or Redistribution

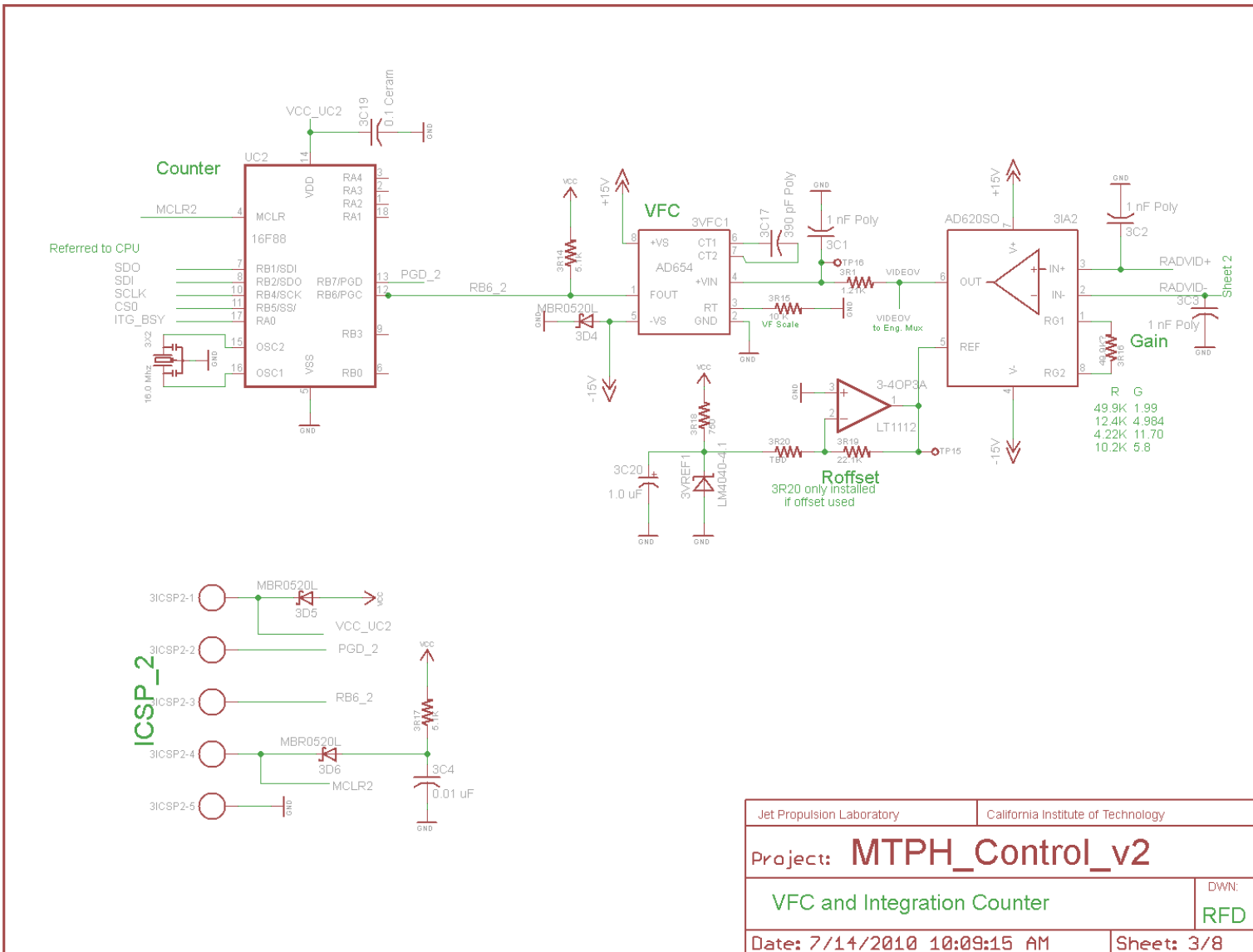

Jet Propulsion Laboratory	California Institute of Technology
Project: MTPH_Control_v2	
VFC and Integration Counter	DWN: RFD
Date: 7/14/2010 10:09:15 AM	Sheet: 3/8

HALO MTP Design Package
 JPL/Caltech PROPRIETARY —Not for Public Release or Redistribution

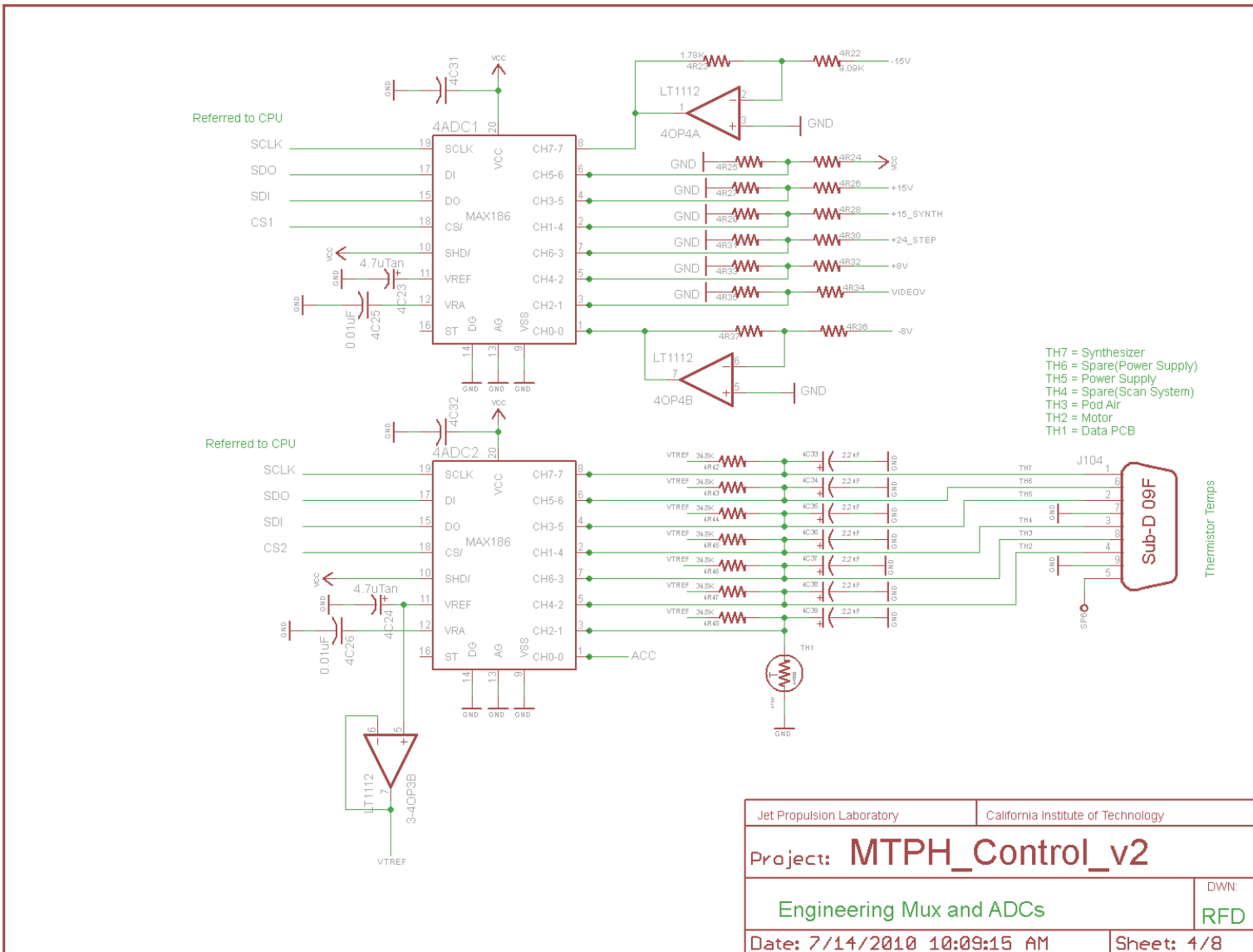

HALO MTP Design Package
JPL/Caltech PROPRIETARY —Not for Public Release or Redistribution

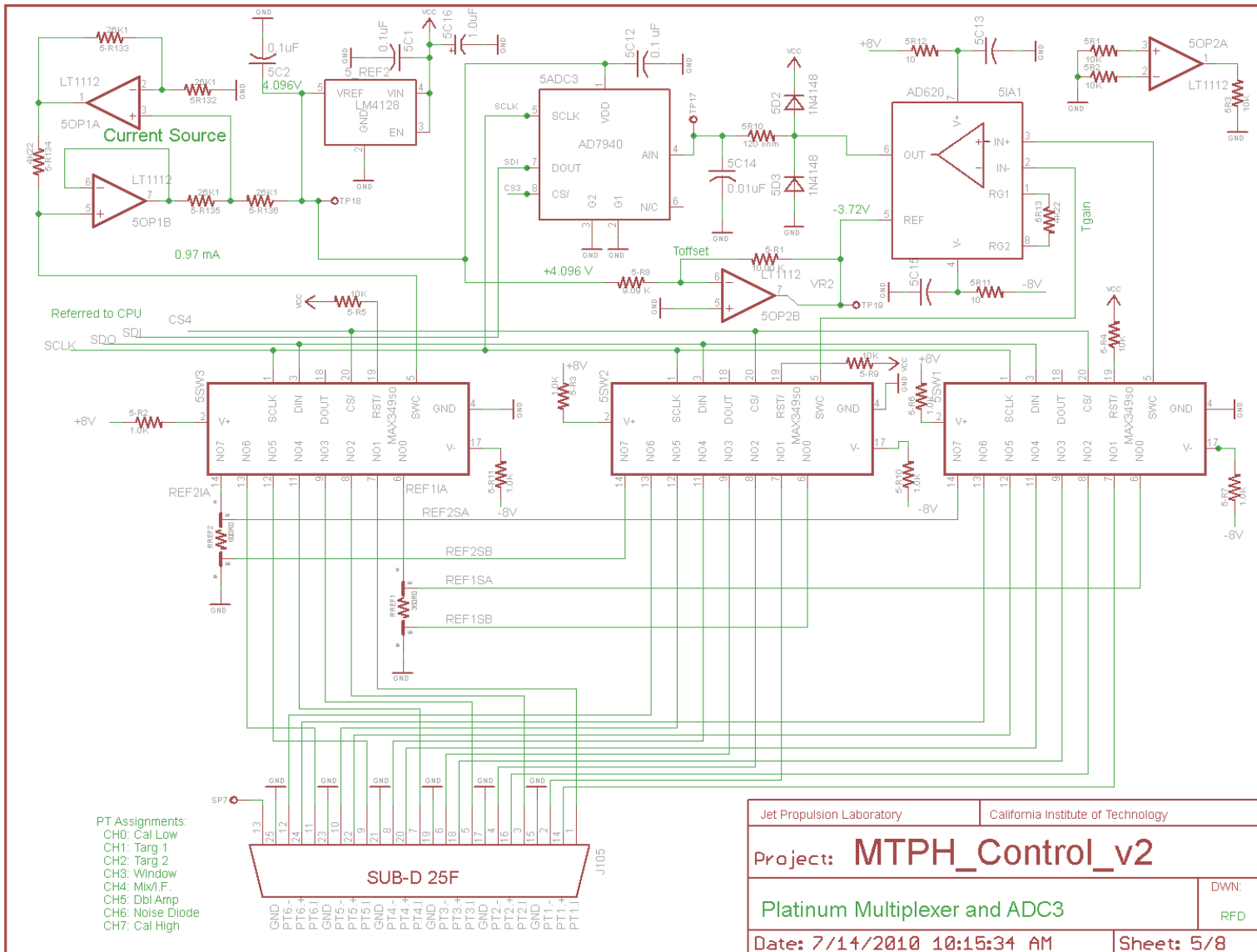

HALO MTP Design Package
 JPL/Caltech PROPRIETARY —Not for Public Release or Redistribution

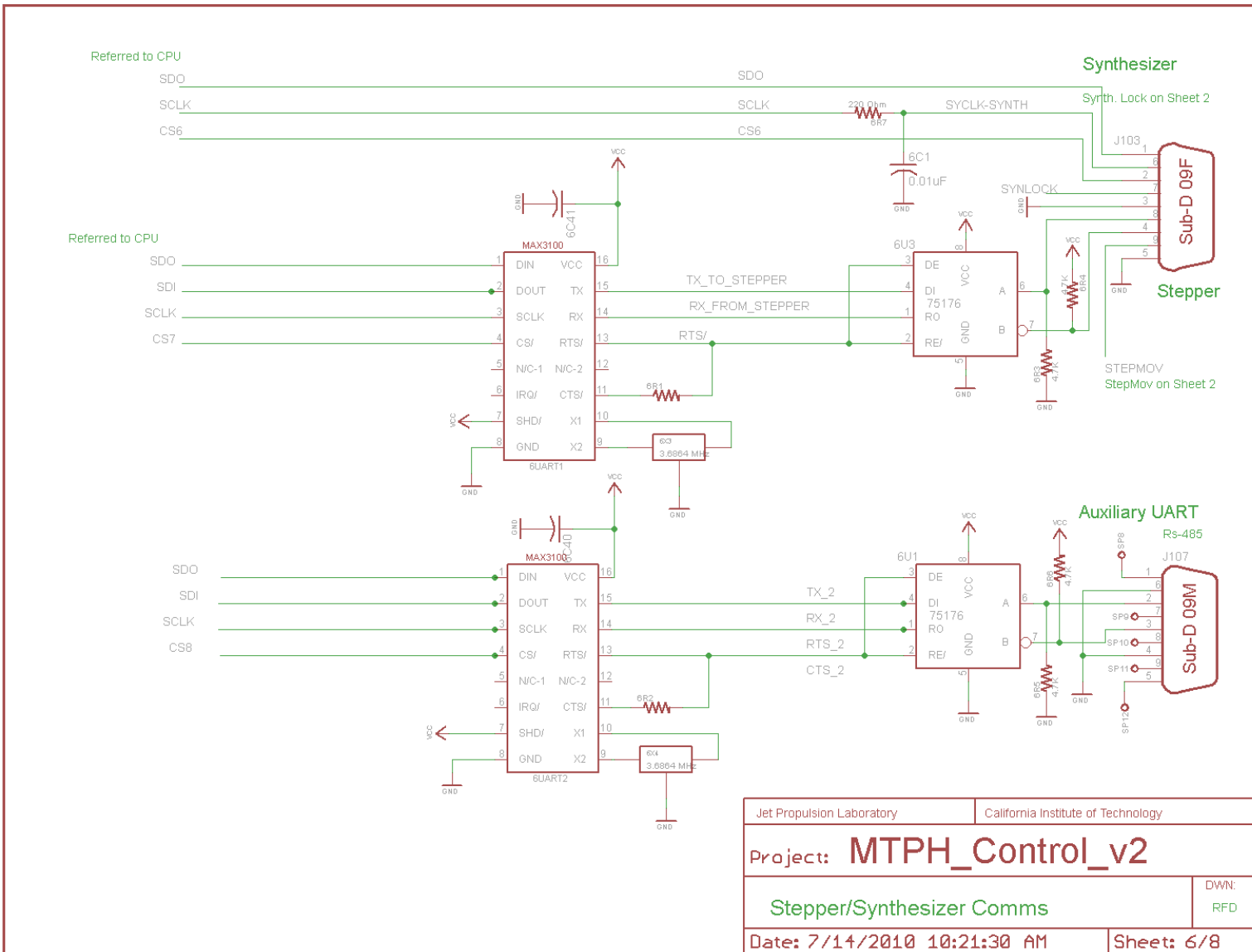

HALO MTP Design Package
 JPL/Caltech PROPRIETARY —Not for Public Release or Redistribution

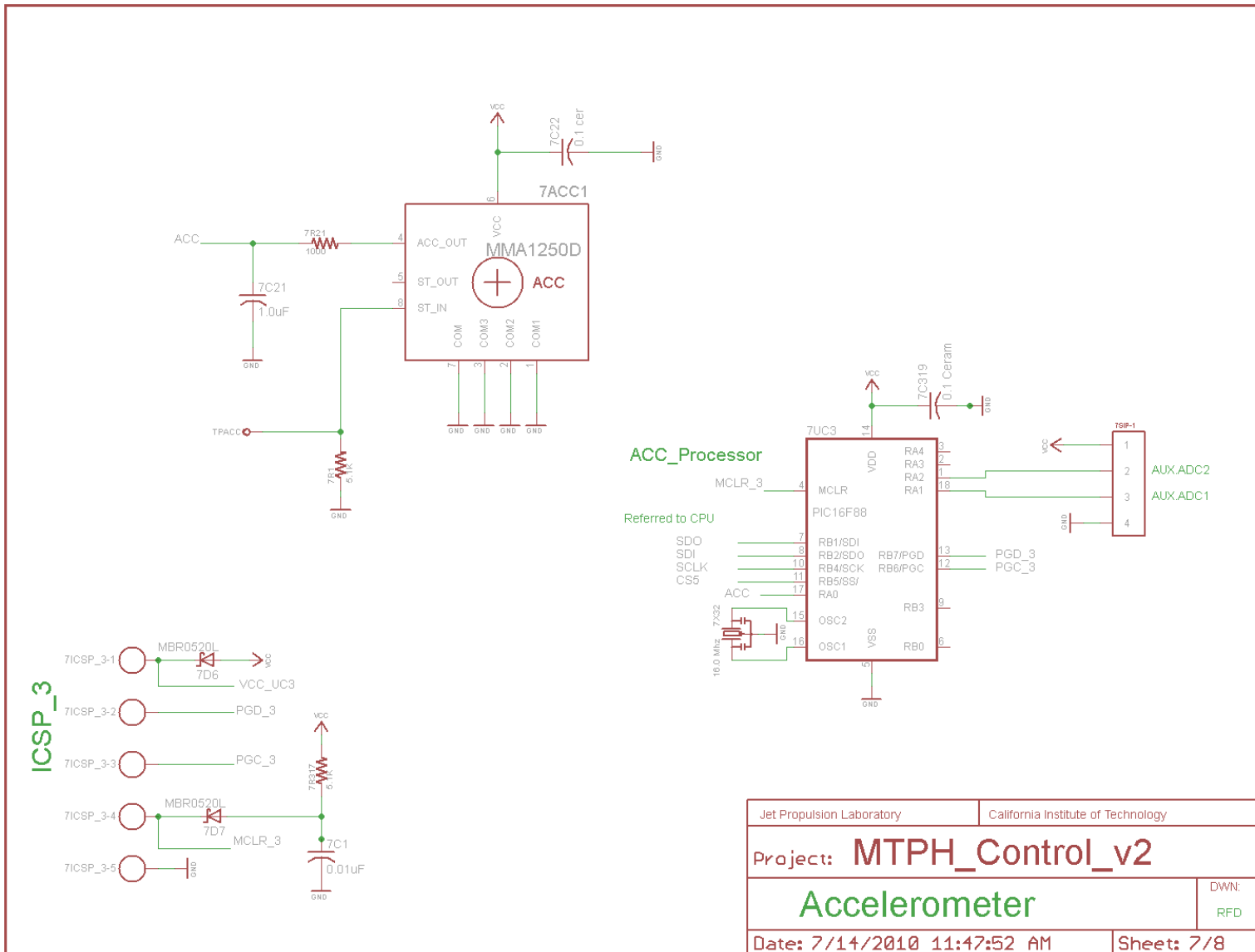

HALO MTP Design Package
 JPL/Caltech PROPRIETARY —Not for Public Release or Redistribution

2006/11/09 Rationalized the power conn. to match ribbon

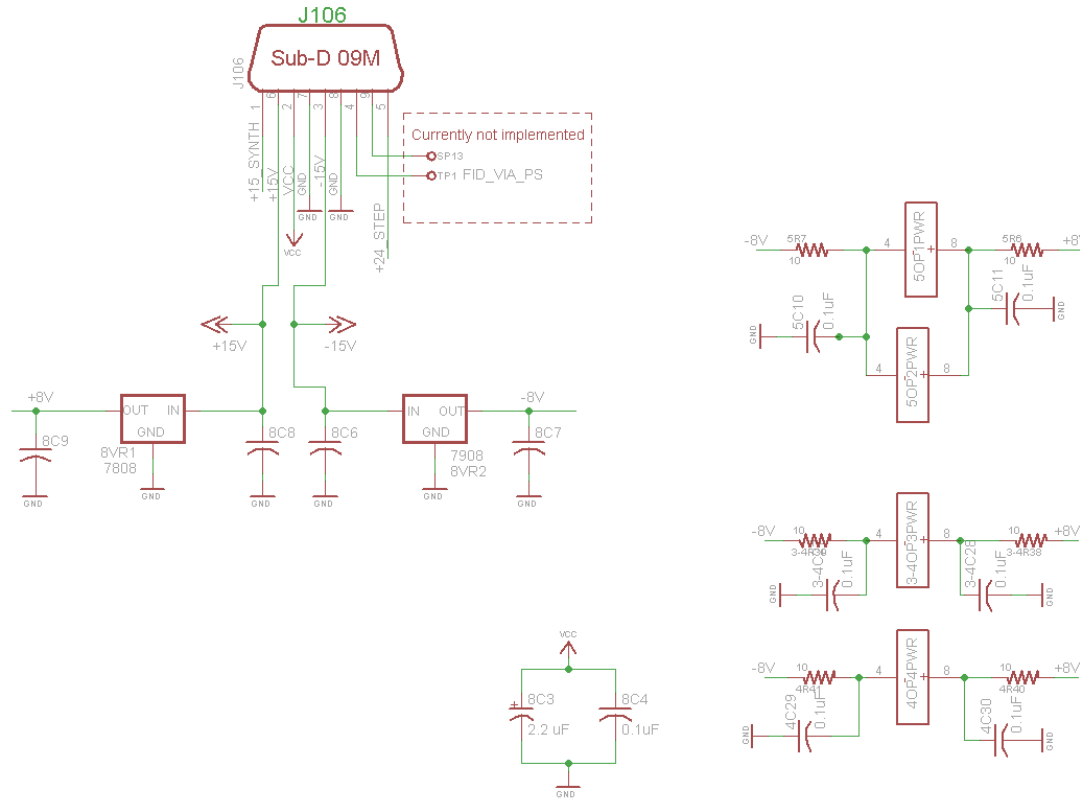

Jet Propulsion Laboratory	California Institute of Technology
Project: MTPH_Control_v2	
Power Distribution	
DWN: RFD	
Date: 7/14/2010 10:25:51 AM	Sheet: 8/8

15 MTP-H Wiring

The first figure below shows the cable drawing for all signals between the *MTP Power and Status Panel* in the cabin and the connector on the back of the DMT canister. The cabin portion of the cable will be long enough (45 feet) so that any rack location in the cabin can be reached via underfloor and crossover conduits from the Wing Connector #4.

The next drawing shows a schematic of the major wiring blocks: 100 Block for the *Controller Board*, 200 Block for the *Power Supply and Synthesizer Plate*, 300 Block for the *Radiometer Plate*, and 400 Block for the *Scan Area*.

The third drawing shows the 200 Block wiring for the *Power Supply and Synthesizer Plate*. There are three classes of wiring in the MTP canister: 115 VAC 60 Hz power, low-voltage DC power, and control/data signals.

115 VAC power from the wing store passes directly from the connector through a 5 A breaker to a terminal strip (TB1). An Acopian power supply (PS6) operates from the protected AC line at TB1 to generate 12 VDC to power the temperature control circuits. The temperature control heater power is from the same protected 115 VAC line. A Teledyne 602-1W relay (RLY1), switches the AC power from TB1 to the remaining 5 Acopian power supplies on a signal from the cabin *MTP Power and Status Panel*. When this relay is **On**, the instrument is in **Operate** mode, and can receive and execute commands from the MCC.

Low-voltage DC power is distributed to the various subsystems from another terminal strip (TB2). The synthesizer, being on the same plate as the power supplies, is wired directly to TB2 through connectors P203/J203. The *Temperature Control* subsystems are powered from TB1 and TB2 via J210 (Radiometer, Target, Controller enclosure) and P204 (*Power Supply/Synthesizer Plate*). All other subsystems receive DC power from TB2 via J202/P202 and the Main Wiring Harness (see last figure in this section).

The controller PCB is connected to all other subsystems by the Main Wiring Harness (Sheet 5 of MTP-H Wiring below). Through the Main Harness, commands are sent to the stepper controller, the radiometer and the synthesizer, and data (temperatures, voltages, radiometer output) is read back from all parts of the instrument.

Drawings for the 300 Block (Radiometer plate) and 400 Block (Scan Area) can also be found below.

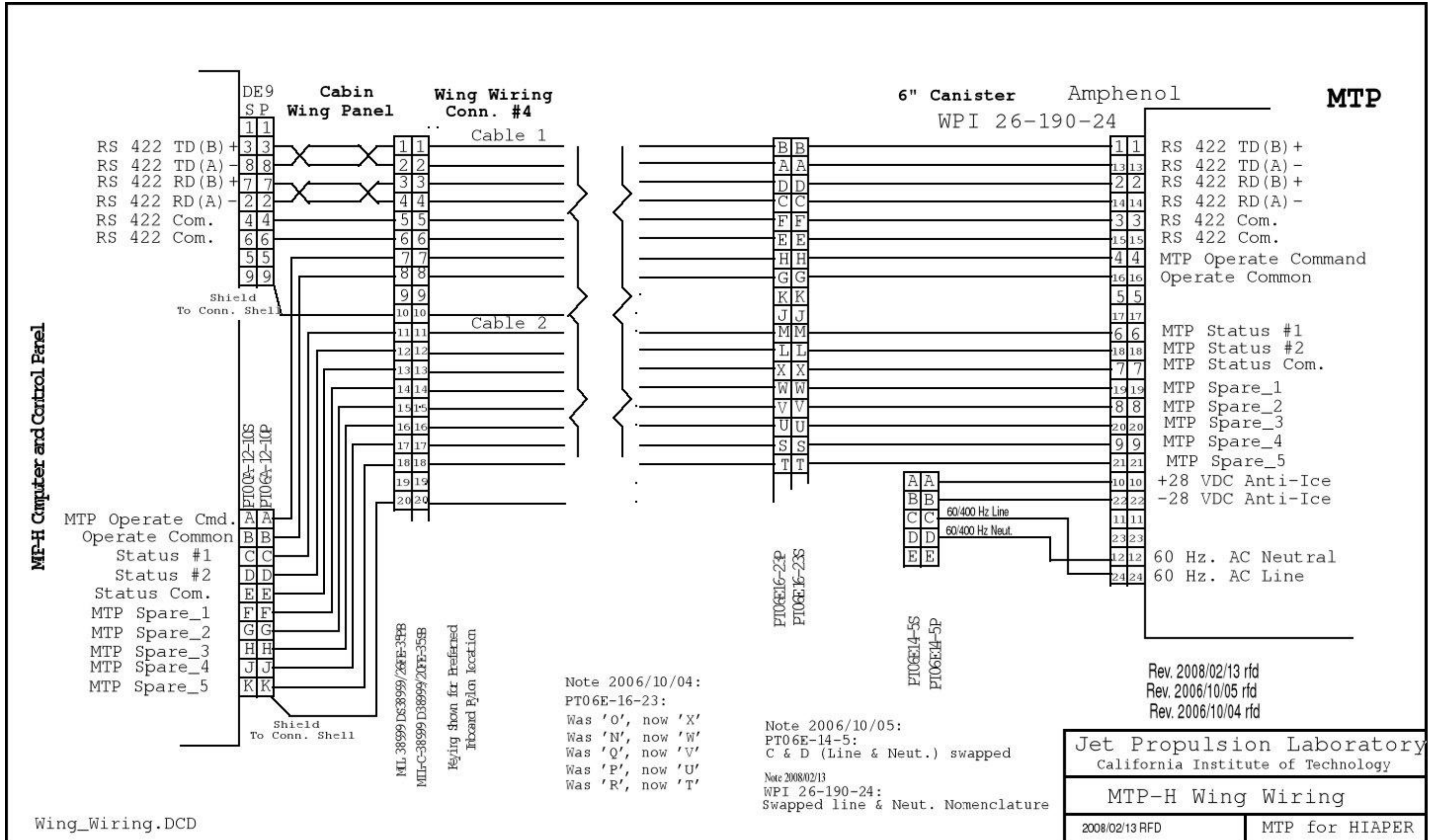

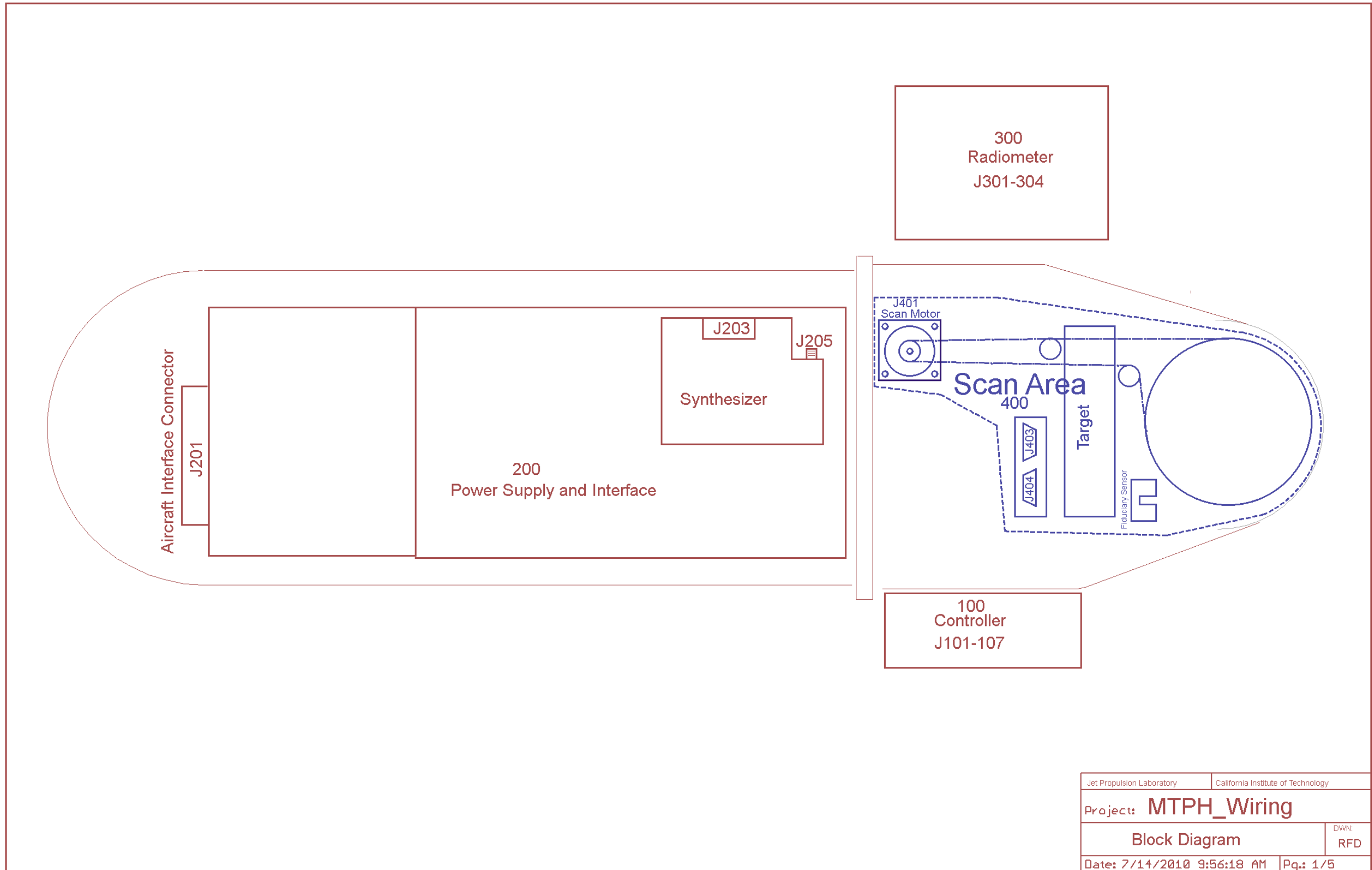

Jet Propulsion Laboratory	California Institute of Technology
Project: MTPH_Wiring	
Block Diagram	DWN: RFD
Date: 7/14/2010 9:56:18 AM	Pg.: 1/5

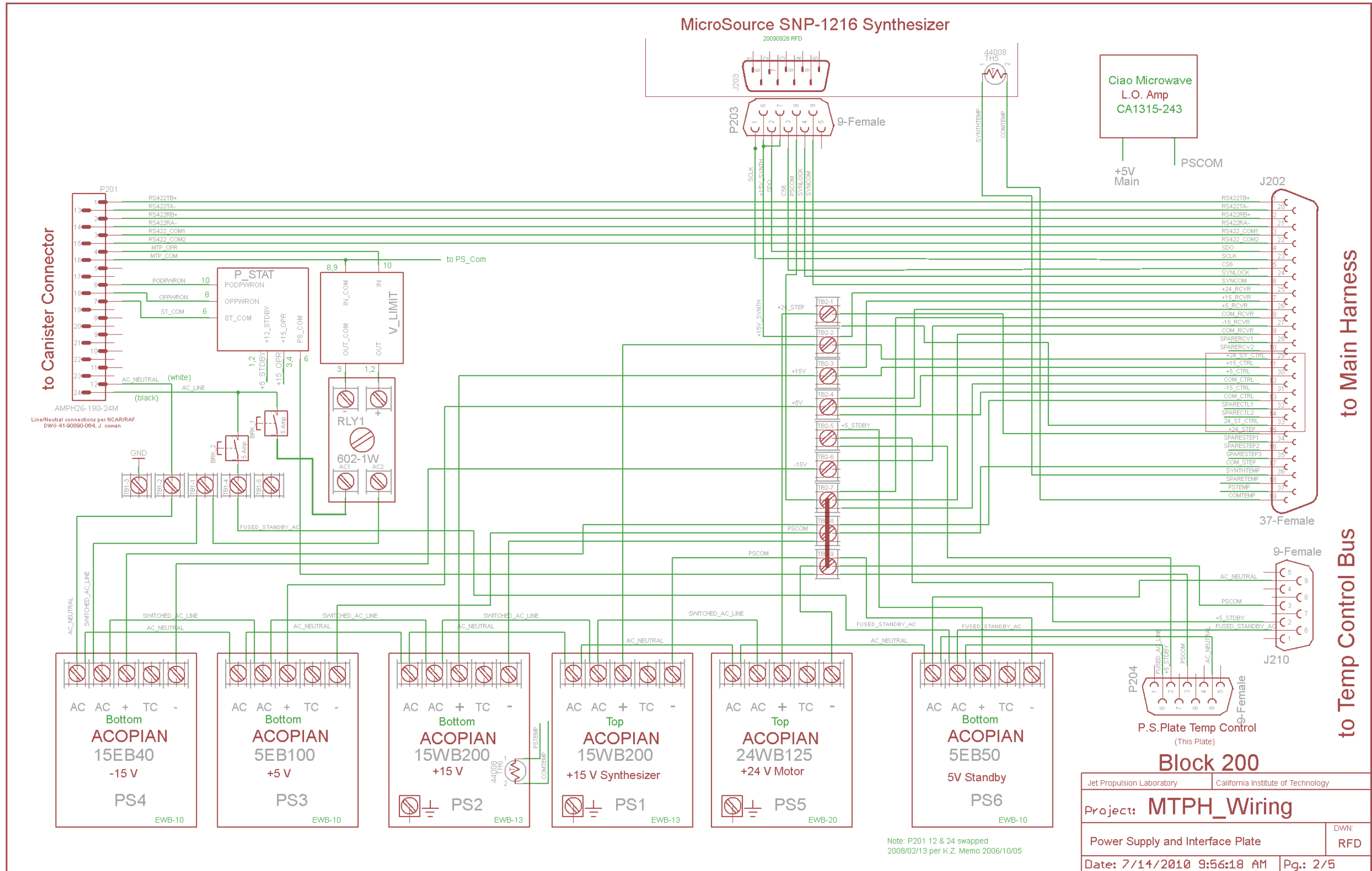

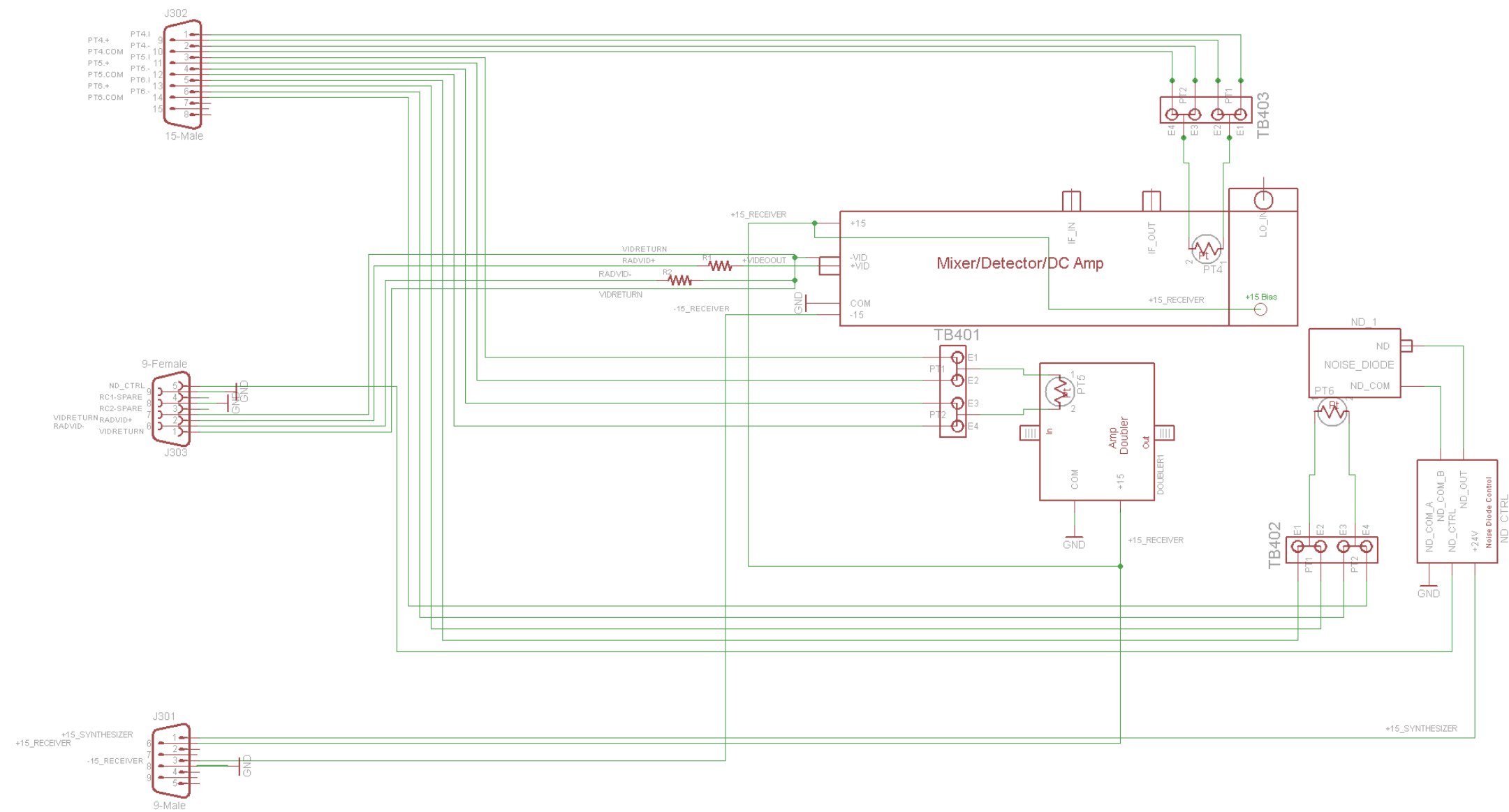

Block 300

Jet Propulsion Laboratory	California Institute of Technology
Project: MTPH_Wiring	
Radiometer Plate Wiring	
DWN: RFD	
Date: 7/14/2010 9:56:18 AM	Pg.: 3/5

To Main Harness

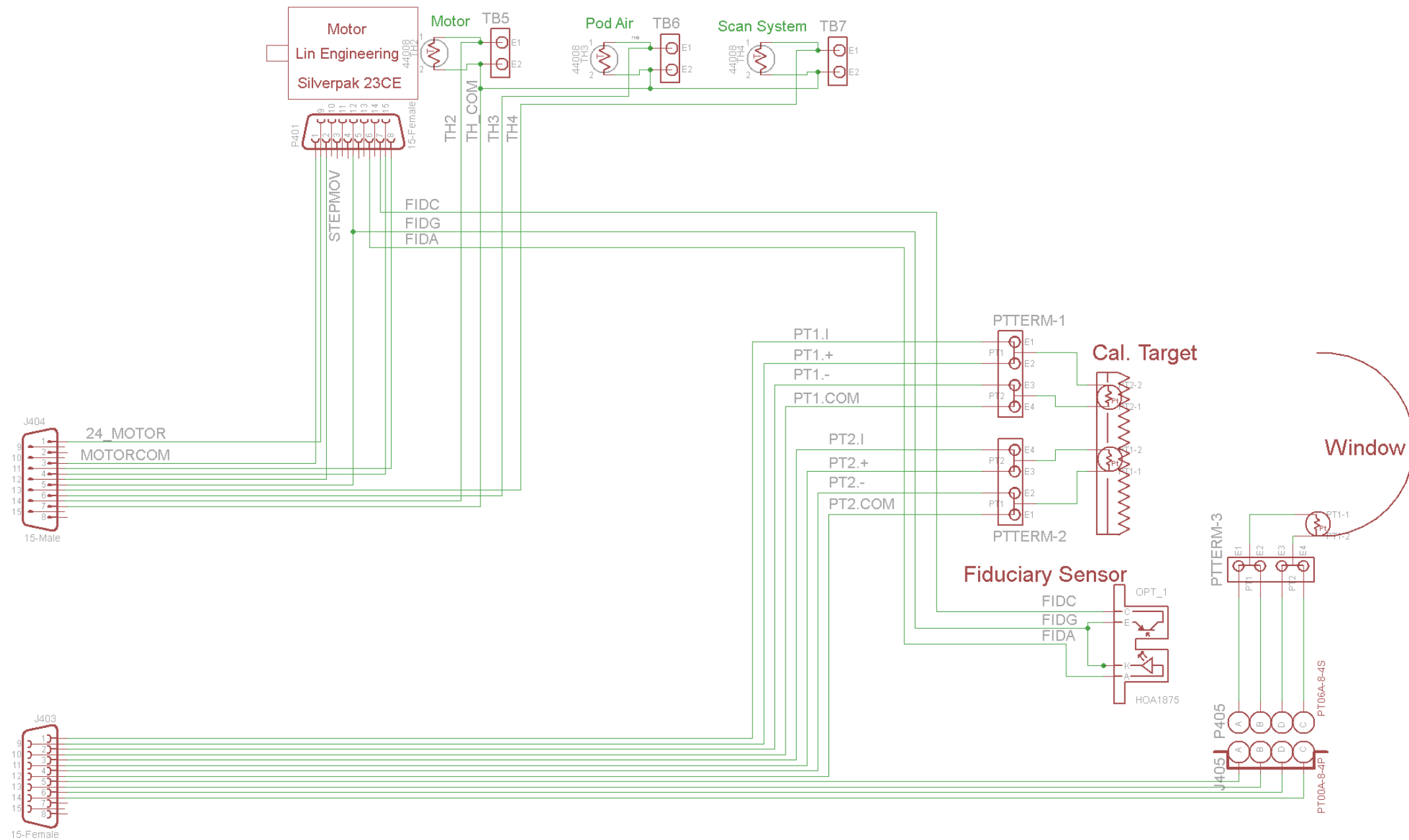

Block 400

Jet Propulsion Laboratory	California Institute of Technology
Project: MTPH_Wiring	
Scan Area Wiring	DWN: RFD
Date: 7/14/2010 9:56:18 AM	Pg.: 4/5

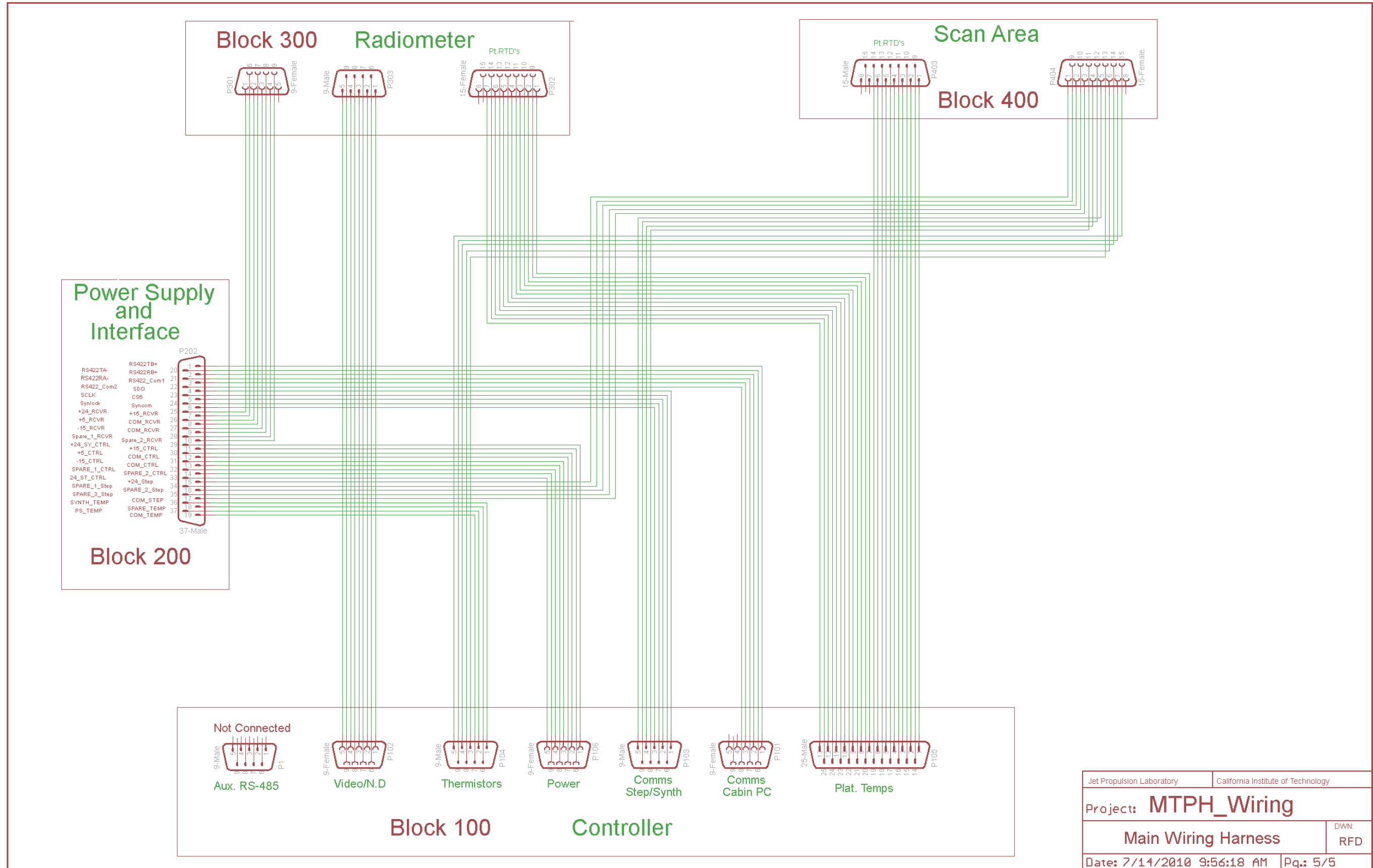

Jet Propulsion Laboratory	California Institute of Technology
Project: MTPH_Wiring	
Main Wiring Harness	
DWN: RFD	
Date: 7/14/2010 9:56:18 AM	Pg.: 5/5

16 Temperature Controller PIC Software Listing

Beginning on the next page is the C code used to program the PIC on the *Temperature Controller Boards*.

HALO MTP Design Package
JPL/Caltech PROPRIETARY —Not for Public Release or Redistribution

```
// California Institute of Technology
// Jet Propulsion Laboratory
// Richard F. Denning
// TCPI_C.C
//
// Temperature controller in PICC Lite for 12F675 with P, I terms
// This version used for WAC-II temp control for AVE/Houston '05
// 03.03.24 - Translated from TCPID.asm - RFD
// 03.04.09 - Working version archived
//
// Hardware Notes:
// PIC12F675 uses internal 4 MHz oscillator
// no External _MCLR connection required
//
#include <pic.h> // code in pic.h gets the pic type from the configure
dialog // and includes, in this case,
'pic12F6x.h'
//
// Configuration Fuses
    __CONFIG(0x11C4); // Configuration Fuses:
                        // - INTIO Oscillator
                        // - 70 msecs Power Up Timer On
                        // - Watchdog Timer Off
                        // - Code Protection Off
                        // - MCLR internal , I/O
                        // - 70 msecs Power Up Timer On
                        // - Watchdog Timer Off
                        // - Code Protection Off
                        // - BODEN Enabled
// -----
// -----Global Variables-----
volatile unsigned int RTC = 0; // Real Time Clock Counter
volatile unsigned int ADC0; // space for ADC readings
volatile unsigned int ADC1;
volatile unsigned int ADC3;
volatile unsigned char adtmp;
volatile unsigned char adstart;
//
signed int P;
signed int Pc;
signed int I;
signed int D;
signed int Ton = 0; // these are the PWM vars
signed int Toff = 0x200;
//
// these are used in the Serial out routines
unsigned char bitimr ;
unsigned int charout;
unsigned char charhi;
unsigned char charlo;
signed int sbcnt;
volatile char bval;
signed char tmp;

//
```

```
volatile char zz;
volatile int xx;
volatile int yy;
// const char version[17] = "TCPIC 041129rfd\0";
//
// -----
// -----Convert Byte to ascii hex-----
void cvb2asc(char cvbin)
{
    charlo = cvbin & 0x0f;
    charhi = ((cvbin & 0xf0)/16);
//
    if (charhi > 9)
        charhi =charhi + 55;
    else
        charhi= charhi + 48;

    if (charlo > 9)
        charlo =charlo + 55;
    else
        charlo= charlo + 48;

} // end cvb2asc
// -----
// -----Bit-Bang Serial Output-----
void bittime(char bloops)
{
    bitimr = bloops;
    {
        #asm
            decfsz    _bitimr, f ; must be a global
            goto $-1
        #endasm
    }
} // end bittime
//
// Emit
void emit(unsigned char emasc) // sends emasc out on GPIO2 as RS-
232
{
    charout = emasc ;
    GPIO2 = 1; // generate start bit
    bittime(22);
    bval=1;

    for (sbcnt = 0; sbcnt <= 7; sbcnt++ )
    {
        {
            if (charout & bval)
                GPIO2 = 0; // note inversion for RS-232...
            else
                GPIO2 = 1;
        }
        bval=bval*2;
    }
}
```

HALO MTP Design Package
 JPL/Caltech PROPRIETARY —Not for Public Release or Redistribution

```

    bittime(22);

    }      // end for

    GPIO2 = 0; // generate 2 stop bits
    bittime(22);
    bittime(22);
} // End Emit
//
// -----Bit-Bang Serial Output-----
// -----
// -----version out-----
void vout(void)
{
    char version[] = "TCPIC 050413rfd\0";
    char i;
    while (version[i] != '\0')
    {
        emit(version[i]);
        i++;
    }
    emit(0x0d);
    emit(0x0a);
}
// -----End of version out-----
// -----
// -----INITIO-----
void initio (void)
{
    CMCON = 0b00000111; // Comparators off
    ADCON0 = 0b10000001; // ADC right justify, ADC enabled
    ANSEL = 0b00001011; // ADC Clk= Fosc/2, CH0, CH1, CH3 = ADC
    TRISIO = 0b00011011; // GPIO bits 2, 5 = output
    GPIO = 0b00000000; // Startup value for GPIO
}
//
// -----INITIO-----
// -----
// -----ADC read-----
int unsigned ADC(unsigned char adch)
{
    adtmp = (adch << 2) ;
    adstart = (adtmp | 0b10000001); // | = OR
    ADCON0 = adstart; // this selects the channel, but doesn't start
adc
    // put some settling time here for internal multiplexer
    bittime(3);
    adstart = adstart | 2; // this starts it
    ADCON0 = adstart;

    while(ADCON0 & 2); // wait for /done bit

    return ((ADRESH << 8)+ ADRESL);
}

```

```

}

// -----ADC read-----
// -----
// -----Send out 16 bit int-----
void send16( unsigned int s16, unsigned char s16t)
{
    cvb2asc(s16 >> 8);
    emit(charhi);
    emit(charlo);
    cvb2asc(s16 & 0xff);
    emit(charhi);
    emit(charlo);
    emit(s16t);
}

// -----Send out 16 bit int as ascii-----
// -----
// -----Long delays-----
void ldelay (unsigned int ldt)
{
    yy = 0;
    while (yy <= ldt)
    {
        bittime(0xCC);
        bittime(0x66);
        yy++;
    }
}

// -----Long delays-----
// -----
// -----ADC-----
void readADC(void)
{
    ADC0 = ADC(0);
    ADC1 = ADC(1);
    ADC3 = ADC(3);
}

// -----ADC-----
// -----
// -----Report-----
void report(void)
{
    send16(ADC0, 0x20);
    send16(ADC1, 0x20);
    send16(ADC3, 0x20);
    send16(P, 0x20);
    send16(I, 0x20);
    send16(D, 0x20);
    send16(Ton, 0x0d); // cr to end the line
}

// -----Report-----
// -----
// -----PWM Calc-----

```

HALO MTP Design Package
 JPL/Caltech PROPRIETARY —Not for Public Release or Redistribution

```

void pwmcalc(void)
{
    signed int ptemp;

    // Calc the current P value
    P = (ADC0 - 0x200);
    P = P * 16; // left shift 4, retain sign bit
    P = P + 0x100;
    // integrate the error, check limits, then add in the Integration
    if ((ADC0 > 0x1F0) & (ADC0 < 0x210)) // don't do anything
with I
    {
        // if
far from null
        if (ADC0 > 0x200) // increment or decrement I as needed
            I = I + 1;
        if (ADC0 < 0x200)
            I = I - 1;
    //
        I = I + (ADC0 - 0x200); // This should increase the
response

        if (I > 0xFF) // limit I to +/- 0xFF
            I = 0xFF;
        if (I < -0xFF)
            I = -0xFF;
    }
    else
        I = 0; // sets I to zero if far from home
        // avoids wrap-up of I

    //

    //

    ptemp = P + Pc + I;

    if (ptemp < 0)
        ptemp = 0;
    if (ptemp > 0x200)
        ptemp = 0x200;
    //
    Set the PWM times
    Ton = ptemp;
    Toff = 0x200 - Ton;
    // for diagnosis, will put out GPIO state as 'D' term which isn't used
now
    D = GPIO;
}
// -----PWM Calc-----
// -----
// -----Cycle-----
void cycle(void)
{
    GPIO5 = 1;
    ldelay(Ton);
    GPIO5 = 0;
    if (Ton == 0x200) // ensure max time for full scale
        GPIO5 = 1;
}

```

HALO MTP Design Package
JPL/Caltech PROPRIETARY —Not for Public Release or Redistribution

```
    ldelay(Toff);  
  }  
// -----Cycle-----  
// -----  
// -----MAIN-----  
// Mainline  
void main(void)           // Mainline  
{  
  // hardware initialization  
  initio();  
  vout(); // sends out the version string on sign-on  
//  
  while (1)  
  {  
    readADC();  
    pwmcalc();  
    report();  
    cycle();  
  }  
} // End of Main  
// -----MAIN-----  
// -----
```

17 Integration Timer and Counter PIC Software Listing

Beginning on the next page is the assembly language code used to program the PIC on the Controller Board that operates the integration timer and counter.

HALO MTP Design Package
JPL/Caltech PROPRIETARY —Not for Public Release or Redistribution

```
; California Institute of Technology
; Jet Propulsion Laboratory
; Richard F. Denning
; Originally for Breadboard
;
; Integration timer and counter for HIAPER MTP
;
; F88_Integ_IRQ.asm v. 20061023 rfd
; SPI i/o version of integrator/timer from Phoenix MTP
; "I" followed by byte (20mS increments) starts integrator and
; sets 'busy' hi, then low when done.
; "R 0 0 0 0" sends out "R" + 3 bytes of last counter value
;
; from 628Count.asm
; 7/24/02 added command "I" to implement integration timer/counter
;
    list P=16F88, R=DEC
    INCLUDE "p16f88.inc"
;
    CBLOCK 0x020
;
; integration timer/counter registers
;
dlylo
dlymd
dlyhi
tlo
tmid
thi
;
char_lo
char_hi
;
counterlo ;    lo byte, counter store
countermid
counterhi ;    3rd byte
;
inchar
ochar

xx          ; general purpose temporary
YY
ZZ

w_save          ; for interrupt service routine
status_save

    ENDC
;*****
    PAGE

    __CONFIG    __CONFIG1, __CP_OFF & __CCP1_RB0 & __DEBUG_OFF &
__WRT_ENABLE_OFF & __CPD_OFF & __LVP_OFF & __BODEN_ON & __MCLR_OFF &
__PWRTE_ON & __WDT_OFF & __XT_OSC
    __CONFIG    __CONFIG2, __IESO_OFF & __FCMEN_OFF
```

HALO MTP Design Package
JPL/Caltech PROPRIETARY —Not for Public Release or Redistribution

```
ORG 000H
goto main

ORG 004H
goto int_serv

;
; Main line
main
;
;-----
;   disable ADC's on Porta
banksel ADCON0      ;bank 0
clrf  ADCON0

banksel    ANSEL
movlw 0x00
movwf ANSEL

;   turn off comparators
banksel    CMCON ; bank 1
movlw 0x07
movwf CMCON

;-----
; SPI Setup
movlw 0x40
movwf SSPSTAT      ; still bank 1

banksel SSPCON      ; bank 0
movlw 0x24          ; CKP=0
movwf SSPCON

;
; Set PORTA, B i/o state
banksel TRISA
movlw 0x10          ; Busy line = PORTA, 0 ... 1-3 outs for
diagnostic

movwf        TRISA          ; 6, 7 don't exist
                        ; bank 1

movlw 0xFB          ; all IN except RB2/SDO
movwf TRISB          ; bank 1

;
;-----
; serial setup (disable uart)
bsf  STATUS, RP0      ; set to bank 1 for tx status reg
bcf  TXSTA, TXEN      ; disable transmit

;
bcf  STATUS, RP0      ; set to bank 0 for rc status reg
bcf  RCSTA, CREN      ; disable reception
bcf  RCSTA, SPEN      ; disable Serial Port(USART) (bank
0)
;
;-----
bcf  STATUS, RP0 ; back to bank 0
;-----
; Setup default registers for counter/integrator
```

HALO MTP Design Package
 JPL/Caltech PROPRIETARY —Not for Public Release or Redistribution

```

    movlw 0
    movwf dlylo      ;these numbers yield an overall time of ~20ms
per dlyhi
    movlw 26
    movwf dlymd
    movlw 10        ; 10=200 mS
    movwf dlyhi
    goto  Chk4Dat

;
;*****
; Set up interrupt for timer 1 overflow
    banksel PIE1
    movlw 0x00 | (1 << TMR1IE) ; enable T1 int.
    iorwf PIE1, f
    banksel INTCON
    bsf          INTCON, GIE

;
;*****
;   Wait here for next command
Chk4Dat
    banksel      SSPSTAT
    btfss SSPSTAT, BF
    goto  Chk4Dat

;
;   ;if here, cmd chr is waiting in SSPBUF
    call  rcv

;
;-----
; Command interpreter
;   ; rcv returns here with cmd byte in inchar
    movfw inchar
    sublw 'I'
    btfsc STATUS, Z   ; if = 'I' then
    call  integ
;
;                                     else
    movfw inchar
    sublw 'R'
    btfsc STATUS, Z
    call  report

;
cixit
    goto  Chk4Dat
;   wait for next command
;   end of main
;-----
;   common routines
on
    banksel      PORTA
    bsf  PORTA, 0
    return

;
off
    banksel      PORTA
    bcf  PORTA, 0
    return

```

HALO MTP Design Package
 JPL/Caltech PROPRIETARY —Not for Public Release or Redistribution

```

;
;|||||
|
; SPI rcv/send routines
rcv
    ; on entry here, SSPSTAT, BF = chr ready, or wait for new
char
    banksel SSPSTAT          ; bank 1
    btfss SSPSTAT, BF
    goto rcv

    banksel SSPBUF          ; Sw to bank 0
    movf SSPBUF, w          ; rcv returns with chr in w as well as inchar
    movwf inchar

    return ; from rcv
; end of rcv
;-----
;
send2 ; sends ochar out on SPI
    banksel SSPSTAT          ; bank1
sloop2
    btfsc SSPSTAT, BF        ; check if buffer empty
    goto sloop2              ; no, loop back
    banksel SSPBUF          ; yes, load chr.
    movf ochar, w
    movwf SSPBUF            ; ready for transmission
    banksel SSPSTAT
sloop3
    btfss SSPSTAT, BF        ; check if buffer empty
    goto sloop3              ; no, loop back

    banksel SSPBUF
    movf SSPBUF, w
    movwf xx                ; get rid of dummy input chr.
    ;
    return ; from send2
; end send2
;-----
; Do an integration...
integ
    call on                  ; set bsy hi, leave in bank 0
    call rcv                 ; get next byte (ascii= number of 20mS
increments)
    movwf dlyhi ; rcv returns with number in inchar and w
    call count
    call off                  ;bsy lite off

    return ; from integ to command interpret
;*****
; Integration timer/counter
;
; ~200mS DELAY SUBROUTINE WITH 4 MHz CLOCK- dlyhi=10, dlymd
;

```

HALO MTP Design Package
JPL/Caltech PROPRIETARY —Not for Public Release or Redistribution

```
count
    banksel dlylo                ; Everything in sub is on bank 0
    movf dlylo, w                ; init. the delay loops
    movwf tlo
    movf dlymd, w
    movwf tmid
    movf dlyhi, w                ;#instructions*.25(instruction      time,
uS)*12*256*256
    movwf thi
;
    clrf counterhi                ;Reset the count registers
    clrf countermid
    clrf counterlo
;
; make sure tmr1 is off and in correct mode: ext clk, async, t1on=0
    banksel TMR1H                ;TMR1H, L bank 0, INTCON all banks
    movlw 06
    movwf T1CON
    movlw 0
    movwf TMR1H                ;set counter to zero
    movwf TMR1L

    movlw 0xC1
    movwf INTCON
    ;bsf INTCON, PEIE            ; enable interrupt
    banksel PIE1
    movlw 0x01
    movwf PIE1
    banksel T1CON

;
; Start the counter
    bsf T1CON, TMR1ON            ; start T1 counter
    banksel TMR1H                ; back to bank 0
;
cloop000
    movf dlyhi, w                ; init. the delay loops
    movwf thi
cloop00
    movf dlymd, w
    movwf tmid
cloop0
    movf dlylo, w
    movwf tlo
;
cloop
    decfsz tlo, F                ; basic timing loops
    goto cloop
;
    decfsz tmid, F
    goto cloop0
;
    decfsz thi, F
    goto cloop00
;
    ; done counting; tmr1 off , store counter values
```

18 Control and IO PIC Software Listing

Beginning below is a listing of the C code used by the PIC on the Controller Board that performs all the control functions including IO with the MTP Cabin Computer.

HALO MTP Design Package
JPL/Caltech PROPRIETARY —Not for Public Release or Redistribution

```
// MTP_H Controller
//   Use TMR0, 1 msec interrupt as base for RTC ticks by Myke Predko
// Hardware Notes:
// PIC16F876 running at 20 MHz uses HS oscillator
// External _MCLR connection required (16F876 always has MCLR/)
//
//   2006/11/27 Baud Rate increased to 19200, saving ~0.9 sec/cycle
//   2006/11/29 Added 'N' command for noise diode
//   2008/11/24 Converted "F" command to use the MVSR type synthesizers
//   2009/09/10 Converting 'F' Command for the SNP1216 Synthesizer
//             SNP1216 requires 'F 12345.6' for example, decimal always
required
//   2010/09/30 Slowed down SCLK for Synthesizer
//
=====
// Command List:
// F dddd.d Sets frequency for synthesizer, in MHz -
//   7 digits, decimal always required
// I dd = integrate for dd * 20mS
// R = Read results of last integration from counter
//
// M 1 = read all 8 channels of multiplexer 1
// M 2 = read all 8 channels of multiplexer 2
// P = read all 8 platinum RTD channels
//
// S = read status byte:
//       Bit 0 = integrator busy
//       Bit 1 = Stepper moving
//       Bit 2 = Synthesizer out of lock
//       Bit 3 = spare
//
// U/1$$$$$$$ = send string $ to stepper #1 (only one now)
//   See Linn Engineering manual for 23-CE controller for command list
// V = return version date, etc. for this program
// X ss dd ff gg etc.... sends bytes directly to SPI bus for diagnostic
purposes
// Control-C (ascii 3) is caught in interrupt routine and restarts this
program.
//
// -----
// |||
#include <pic.h>

#include "c:\ht-pic\include\stdlib.h"
#include "c:\ht-pic\include\delay.h"      // need both for Ms delays
#include "c:\ht-pic\include\delay.C"      // need both for Ms delays
#include <string.h>
// -----
// Configuration Fuses
#if defined (_16F876A)
#warning PIC16F876A selected
//   __CONFIG(0x03F72);      // PIC16F876A Configuration Word:
//   __CONFIG(0x03B72);      // PIC16F876A Configuration Word:
// If the config stements are commented out, check config bits in MPLab
// before programming!
```

HALO MTP Design Package
 JPL/Caltech PROPRIETARY —Not for Public Release or Redistribution

```

// - HS Oscillator
// - Power Up Timer On
// - Watchdog Timer Off
// - Code Protection Off

#else
#error Unsupported PICmicro MCU selected
#endif

// -----
// ||||||||||||||||||||||||||||||||||||||||||||||||||||||||||||
// -----

// Global Variables
bank1 volatile unsigned int RTC = 0; // Real Time Clock Counter
bank1 static char charry[16];
bank1 volatile bit trisLED1 @ (unsigned) &TRISC*8+1; // LED Physical
Bits
bank1 volatile bit LED1 @ (unsigned) &PORTC*8+1;
bank1 volatile bit trisLED2 @ (unsigned) &TRISC*8+2; // LED Physical
Bits
bank1 volatile bit LED2 @ (unsigned) &PORTC*8+2;

const int LEDon = 1; // Declare values for LED ON/off
const int LEDoff = 0;
char pa, pal, pb, pc; // ram copy of ports value

unsigned char itemp, temp, temp2, temp3[2];
bank1 int iarg[6];
bank1 int inttemp;

char n;
char CharInIndex = 0;
char CmdString[24];
volatile char cmdRdy;
char txchar;
char CharOutIndex = 0;
char cmdi, mi;
char tsi;
unsigned int csmask = 0x3FF; // represents the value for NO chip
selects active; digitizer is act. hi

//int *pt;
static bank2 char spin[8], spout[9], hex[8], nbytes;
bank1 static char StringOut[48];
bank2 char StringIn[16], itsave;
//bank2 char Stemp[32];
bank2 int adcint, adcinth, adcintl; //digtemp[4];
//bank2 char mi;
bank3 int mux[16];

const char version[32] = "MTPH_Control.c-091103>100818\r\n";
// 12345678901234567890123456789 0 12
// -----
// ||||||||||||||||||||||||||||||||||||||||||||||||||||||||||||
// -----

```

HALO MTP Design Package
 JPL/Caltech PROPRIETARY —Not for Public Release or Redistribution

```

// isr send chr
//+++++
char ntox();
void btox();
void lntox();
void itox();
void SPX();
void report();
//+++++
void iputch(unsigned char byte)
{
    while(!TXIF)      /* set when register is empty */
        continue;
    TXREG = byte;

    return;
}
//-----
// Serial I/O primitives
void putch(unsigned char byte)
{
    while(!TXIF)      /* set when register is empty */
        continue;
    TXREG = byte;

    return;
}

unsigned char getch(void)
{
    while(!RCIF)      /* set when register is not empty */
        continue;

    return RCREG;     /* RXD9 and FERR are gone now */
}
// -----
----

void xmit(void)      // transmit a null-terminated string in StringOut to
console
{
    char temp, i;
    i = 0;
    while((temp = StringOut[i++]) != 0)
        putch(temp);
}
// -----
--
//
.....
.
//
// Interrupt Handler
void interrupt intrAll_int(void)      // All sources Interrupt
Handler

```

HALO MTP Design Package
 JPL/Caltech PROPRIETARY —Not for Public Release or Redistribution

```

{

  if (TOIF) {

      TOIF = 0;           // Reset Interrupt Flag

      RTC++;             // Increment the Clock

// Put additional interface code for 1 msec interrupt here

      if ((RTC % 512) == 0)
      {

          pc= (pc ^ 4); // XOR...Toggle LED Bit every 1024
msecs
          PORTC= pc;

      }

  } // endif

// end t0 services
//
.....
// uart rx services this is the 16F876 UART, not the MAX3100

  if (RCIF)           // Serial Character Received
  {
      itemp = RCREG;
      switch (itemp)
      {
          case (0x03):           // CTRL-C?
              asm("goto 0x00"); // Yes, jump to reset vector
              break;
          case (0x08):           // BackSpace?
              if (CharInIndex > 0) // Yes, and Something to
Backspace
                  {
                      iputch(itemp);
                      iputch(' ');
                      iputch(itemp);
                      CharInIndex--;
                  }
              break;
          case (0x0A):           // line feed, ignore
              break;
          case 0x0d:
and Print
              {
                  // "Enter", End String
input
                  // iputch(CharInIndex + 64); // to report len of

                  CharInIndex = 0;
                  cmdRdy = 1;
              }
              break;
          default:
              //if ((itemp >= 'a') && (itemp <= 'z'))
  
```

HALO MTP Design Package
 JPL/Caltech PROPRIETARY —Not for Public Release or Redistribution

```

        //      itemp -= ('a' - 'A');    // make caps

        StringIn[CharInIndex] = itemp;
        CharInIndex++;
        StringIn[CharInIndex] = '\0';
        iputch(itemp);
        //TXREG = itemp;
    }
    RCIF = 0;                // Reset Interrupt Request
} // endif rcif
    RCIF = 0;                // Reset Interrupt Request

} // End Interrupt Handler
// -----
// |||
// -----
char ntox(nx)                // converts nibble to asc hex 0-f
    char nx;
{
    char hx [17] = "0123456789ABCDEF";
    return hx[nx];
}
// -----
// |||
// -----
void btox(bx)                // converts byte to 2 asc digs in hex[]
    char bx;
{
    hex[0] = ntox((bx >> 4) & 0x0f);
    hex[1] = ntox(bx & 0x0f);
    hex[2] = '\0';          // terminate the string
} // end btox
// -----
void lntox(bx)                // converts lo nibble of byte to 1 asc dig in
hex[]
    char bx;
{
    hex[0] = ntox(bx & 0x0f);
    hex[1] = '\0';          // terminate the string
} // end btox
// // |||
// -----
void itox(ix)                // converts integer to 4 asc
digs(0) in hex[]
    int ix;
{
    char bl, bh;
    bl = ix & 0xff;          // low byte
    bh = ((ix >> 8) & 0xff); // high byte

    hex[0] = ntox((bh >> 4) & 0x0f);
    hex[1] = ntox(bh & 0x0f);
    hex[2] = ntox((bl >> 4) & 0x0f);
    hex[3] = ntox(bl & 0x0f);
    hex[4] = '\0';          // terminate the string
}

```

```

} // end itox

// -----
// |||||||||||||||||||||||||||||||||||||||||||||||||||||||||||||||||||||||||||||||||||||||
// -----
void chr2bin(char schr)
{
    char i, j;
    static char ts[11];
    ts[0] = '\0';
    j = 128;
    ts[0] = 'B';
    for (i = 1; i < 9; i++)
    {
        if (schr & j)
            ts[i] = '1';
        else
            ts[i] = '0';

        j = j >> 1;
    }
    ts[i+1] = ' ';
    strcpy(charry, ts);
    return;
}

// -----
// |||||||||||||||||||||||||||||||||||||||||||||||||||||||||||||||||||||||||||||||||||||||
// -----
void enableLED() // Set "eLED" according to
{
    LED1 = LEDoff; // Start with LEDs off
    LED2 = LEDoff;

    trisLED1 = 0; // Make LED1 Bit Output
    trisLED2 = 0; // Make LED2 Bit Output
} // End enableLED

// -----
// |||||||||||||||||||||||||||||||||||||||||||||||||||||||||||||||||||||||||||||||||||||||
// -----
// UART Initialise
void initUART(void)
{
    // Enable the USART
    TXSTA = 0x26;
    RCSTA = 0x96;
    SPBRG = 129; // 9600 bps @ 20 MHz
    // SPBRG = 51; // 9600 bps @ 8 MHz

    temp = RCREG; // clears RCIF
}

```

HALO MTP Design Package
JPL/Caltech PROPRIETARY —Not for Public Release or Redistribution

```
RCIE = 1;           // Enable Receive Interrupt
TXIE = 0;           // Disable Transmit Interrupt
PEIE = 1;           // Enable PIE Interrupt Sources
CharInIndex = 3;
return;
} // end initUART
// -----
// |-----|
// -----
// Send spnb bytes to SPI @ SPADD from spout[]
void SPX(spadd, spnb) // data is passed by globals spin[], spout[]
char spadd, spnb;
{
char i;
int spmask;
--spnb; // need to fix this in several places

PORTA = PORTA | 0x30; // Set all CS's High
PORTB = 0xFF;
spmask = csmask ^ ( 1 << spadd ); // exclusive or: active low
if (spadd <= 7)
{
PORTB = spmask & 0xFF; // low byte, cs
0-7
PORTA = PORTA | 0x30;
}

if (spadd == 8)
{
PORTB = 0xFF;
PORTA = PORTA & 0xEF;
}

if (spadd == 9)
{
PORTB = 0xFF;
PORTA = PORTA & 0xDF;
}

//if (spadd == 6) // Synthesizer needs 1mS setup time after CS6
goes low
// {
// DelayMs (2); // actually ~1.5 mS
// }

for (i = 1; i <= spnb; i++)
{
SSPIF = 0; // clear flag
SSPBUF = spout[i]; // set data to be sent
while(!SSPIF) continue; // wait for buffer to be emptied
while (!STAT_BF) continue;
spin[i - 1] = SSPBUF; // get received data

// 16F88 seems to need CS to rise after each chr
if (spadd == 0)
{
```

HALO MTP Design Package
 JPL/Caltech PROPRIETARY —Not for Public Release or Redistribution

```

                                // returns number of args found
{
  char cmdlen, i, j; // loc in cmd$, substr #
  cmdlen = strlen(CmdString);
  for(i=0; i< cmdlen; i++)
  {
    if(CmdString[i] < '0') // first terminate sub-strings
      CmdString[i] = 0;
  }
  j = 0;
  for(i=0; i < cmdlen; i++)
  {
    if(CmdString[i] == 0) // evaluate the sub-strings
    {
      iarg[j] = atoi(CmdString + i + 1);
      j++;
    }
  }
  return j;
} // end parscmd
//-----
char uartst(char ust)
{
  spout[1] = 0x40;
  spout[2] = 0;
  SPX(7,3); // input goes to spin[0] and

[1]

  return spin[0] & 0x80;
}
// -----
//-----
// toSYNTH
//void toSYNTH() // sends cmdstring(after init chr) to MVSR
Synthesizer on SPI 6
//{
//  char tsi;
//  spout[0] = 'F'; // manually install the leading F that's
stripped in spx
//  SPX(6,2); // Sends the "F"
//  spout[6] = 0; // null to terminate the string if used
later by C
//  strcpy(spout, CmdString);
//  for(tsi = 1; tsi <= 5; tsi++) // Send remaing 5 chars
//  {
//      spout[tsi] = CmdString[tsi];
//  }
//  SPX(6, 7); //SPX(6, 6); need to fix these
several places
//
//  strcpy(StringOut, spout); // test only
//  strcat(StringOut, "\r\n"); // test only
//  xmit(); // test only
//
//} // end of toSYNTH
//-----

```

HALO MTP Design Package
JPL/Caltech PROPRIETARY —Not for Public Release or Redistribution

```
// toUART
void toUART()      // sends cmdstring(after init chr) to Stepper UART
{
    char tui;

    spout[1] = 0xC4;      // irq on rcv for diagnostic (this is in
UART)
    //spout[2] = 0x0A;      // config. baud =9600 w/1.8342
xtal, 1 stop bit
    spout[2] = 0x0B;      // config. baud =9600 w/3.6864 xtal, 1
stop bit
    SPX(7, 3);           // spadd, spnb
    DelayMs(3);

    spout[1] = 0x84;      // set RTS, no transmission yet
    spout[2] = 0x00;
    SPX(7, 3);           // spadd, spnb
    DelayMs(3);

    spout[1] = 0x80;
    for(tui = 1; tui <= (strlen(CmdString)-1); tui++) // skip leading
chr. ('U')
    {
        spout[2] = CmdString[tui];
        SPX(7, 3);      //SPX(7, 2); need to fix these
several places
        DelayMs(4);      // wait for rs485 transmission
        //DelayMs(10);      // wait for rs485
transmission
    }
    spout[2]=13;          //add CR
    SPX(7, 3);
    DelayMs(7);          // 15 was worse -was 10 (wait for rs485
transmission)

    // spout[2]=10;      //add LF
    // SPX(7, 3);
    // DelayMs(10);      // wait for rs485 transmission
    // DelayMs(10);      // diagnostic

    spout[1] = 0x86;      // Release RTS
    spout[2] = 0;
    SPX(7, 3);

    spout[1] = 0xC4;      // irq bit on rcv chr.
    //spout[2] = 0x0A;      // config. baud =9600 w/1.8342
xtal, 1 stop bit
    spout[2] = 0x0B;      // config. baud =9600 w/3.6864 xtal, 1
stop bit
    SPX(7, 3);           // spadd, spnb
    DelayMs(3);          // actually ~3 mS

} // end of toUART
//-----
// frUART
```

HALO MTP Design Package
JPL/Caltech PROPRIETARY —Not for Public Release or Redistribution

```
void frUART()      // gets UART string from Stepper UART
{
    char ust, eos, frdx, di;

    // .....set up UART.....
    // spout[1] = 0xC4;      // irq bit on rcv chr.
    // spout[2] = 0x0A;      // config. baud =9600 w/1.8342 xtal
    // spout[2] = 0x0B;      // config. baud =9600 w/3.6864 xtal
    // SPX(7, 3);           // spadd, spnb
    // DelayMs(15);
    // spout[1] = 0x86;      // clear RTS
    // spout[2] = 0x00;
    // SPX(7, 3);           // spadd, spnb
    // ''''''''''check UART status''''''''''
    eos = 0;
    //StringOut has been started with "\r\nstep:" in cmd decoder
    frdx = strlen(StringOut);
    while(eos == 0)      // until end of string
    {
        while(ust == 0) // wait for rcv chr
        {
            ust = uartst(ust);
            DelayUs(10); //
        } // end of while(ust == 0)

        // get chr
        spout[1] = 0;
        spout[2] = 0;
        SPX(7, 3);

        //20100930 rfd PORTC = PORTC | 1; // found commented on
code from 20090217
        //      DelayMs(1);           // actually ~.3 mS

        //for(di = 0; di < 7; di++)
        //DelayUs(214); // estimated best for n = 7 = 0.96 mS
        DelayMs(1); // estimated best for n = 7 = 0.96 mS
        //      DelayUs(200);           // 7 of these = 0.9 mS
2006/10/04
                                           // 6 bad, 7, 8 good, 9
        bad

        //PORTC = PORTC & 0xFE;// found commented on code from
20090217

        switch(spin[1]) // Allmotion controller sends 'ETX' (=
chr$(3)) at end
        {
            case 3:
                eos = 1;
                break;
            case 0x0D:
                //eos = 1;
                break;
            case 0x0A:
                break;
        }
    }
}
```

HALO MTP Design Package
 JPL/Caltech PROPRIETARY —Not for Public Release or Redistribution

```

        //eos = 1;
        break;
    default:
        StringOut[frdx] = spin[1];
        frdx++;
        if(frdx > 45) frdx = 45;
        break;
    } // end of switch

} // end of while(eos == 0)
spout[1] = 0xC4; // irq bit on rcv chr.
spout[2] = 0x0A; // config. baud =9600 w/1.8342 xtal
SPX(7, 3); // spadd, spnb
//DelayMs(15);
DelayMs(5);

// got complete string now
StringOut[frdx] = 0; // terminate string
}
// end of frUART
// -----
// ustat
void ustat(void)
{
    // get Stepper UART status
    strcpy(StringOut, "\r\nS:");
    spout[1] = 0x40;
    spout[2]= 00;
    SPX(7, 3);
    btox(spin[0]);
    strcat(StringOut, hex);
    btox(spin[1]);
    strcat(StringOut, hex);

    strcat(StringOut, "\r\n");
    xmit();
}
// end of ustat
// -----
// reverse bit order in an integer
int reverse(unsigned int x)
{
    unsigned int h = 0;
    int i = 0;

    for(h = i = 0; i < 16; i++)
    {
        h = (h<<1)+ (x & 1);
        x >>= 1;
    }

    return h;
}
// end of reverse
// -----
// |||
// |||

```

HALO MTP Design Package
 JPL/Caltech PROPRIETARY —Not for Public Release or Redistribution

```

// |
// Mainline
void main(void) // Template Mainline

{

// hardware interface initialization
// ADCON1 = 0x06; // pg. 29 16F876 manual
// TRISA = 0b00001111; // 4, 5 are chip selects 8, 9, 0-3
// flags inputs, 6,7 don't exist
// TRISB = 0; // PB all outputs
// TRISC = 0xD0; // 0=N.D. out , 1, 2 spare (LED or
// ??)
// // 6,7 UART bits (pg 85)
// PORTA = 0x3F; // CS's hi
// PORTB = 0xFF;

// TMR0 = 0; // Reset the Timer for Start
// OPTION = 0xD1; // Assign Prescaler to TMR0
// OPTION = 0x02; // Assign Prescaler to TMR0
// // Prescaler is /8
// TOIE = 1; // Enable Timer Interrupts
// TOCS = 0; // Enable Timer
// // TOIE = 0; // Disable Timer Interrupts
// // TOCS = 1; // Disable Timer
////
// initUART();
// CCP1CON = 0;

//
// ADCON0 = 0; // Disable ADC's
// ADCON1 = 0x06;

// Setup Timer2 for use as SPI clk
// T2CON = 0x05; // on, prescale = 4
// PR2 = 0x01; // normal SPI rate ~ 330
// KHz/1.5uS
// // PR2 = 0x10; // 16 clocks = 3.125 uS
// // = 160 KHz
// // PR2 = 0x40; // 64 clocks = 50 uS high/low = 10
// KHz Synth. only(see 'F' cmd)
// // PR2 = 0x80; // 128 clocks = 20 KHz

// Setup the SSP for SPI
// SSPCON2 = 0; // these are all IIC bits
// SSPEN = 0; // turn port off til set-up
// SSPSTAT = 0x40; // 0xC0;
// // SSPCON = 0b00100010; // 0010 = ckp=0,sspen=1,master, 1/64 clk
// // SSPCON = 0b00100001; // 0010 = ckp=0,sspen=1,master, 1/16 clk
// // SSPCON = 0b00100011; // 0011 = " " " " ,
// tmr2 clk
//

// GIE = 1; // Enable Interrupts
// // GIE = 0; // Disable Interrupts

//*****
// |

```

HALO MTP Design Package
 JPL/Caltech PROPRIETARY —Not for Public Release or Redistribution

```

//*****
strcpy(StringOut, version); // send version as logon
xmit();
StringIn[0] = '0';
CharInIndex = 0;

while (1 == 1) // Loop forever
{
// Command interpreter
if (cmdRdy)
{
strcpy(CmdString, StringIn);
StringIn[0] = '\0'; // effectively
Erase StringIn

switch (CmdString[0]) // Should be first chr of cmd
{
case 'A': // development diagnostic

strcpy(StringOut, "\r\nA:"); // start the
return string
n = parscmd(); // parses input$
into as many #'s as it finds
pb = (char) iarg[0]; // first number after
"A"
btox(pb); // conv to hex$
strcat(StringOut, hex);
strcat(StringOut, " ");
PORTB = pb; // Stick all 8
bits into PB

n = (char) iarg[1]; // second number
after "A"
btox(n); // conv to hex$
strcat(StringOut, hex);
strcat(StringOut, " ");
n = n & 0x03; // mask off
unused bits
pa = PORTA; // get current
PORTA value

pa = pa & 0xFC; // mask off our bits
pa = pa | n; // or it in
PORTA = pa;

strcat(StringOut, "\r\n");
xmit();
break;

// case 'F': // MVSR version
// //2008/11/24 changes to just pass the string to
// the mvsr synth.
// //
// // spout[1] = 'F';
// // for(tsi = 2; tsi <= 6; tsi++) // Send remaining
// 5 chars
// //
// // {
// // spout[tsi] = CmdString[tsi - 1];

```

HALO MTP Design Package
 JPL/Caltech PROPRIETARY —Not for Public Release or Redistribution

```

//          }
//          spout[7] = 0;          // null to terminate
the string if used later by C
//          SPX(6,7);          // ,7 means ,6.. fix
later
//
//          strcpy(StringOut, "\r\n"); // build up a string
to echo
//          strcat(StringOut, CmdString);
//          strcat(StringOut, "\r\n");
//
//          xmit(); // echo back
//
//          //toSYNTH(); // send cmdstring to synth via SPI
//          //frSYNTH(); // Response not currently
implemented
//          break;
//
//          case 'F': //SNP1216 Version
//          //2008/11/24 changes to just pass the string to
the SNP synth.
//          // Assumes 'F' command followed by 7 digits
("Fxxxxx.x")
//          PR2 = 0x20; //0x18; //0x28; // = baud rate
slow for synth.
//          SSPSTAT = 0; // Change SPI sequence for
synth. this works for SNP if ~5uS delay added
//          // in sclk to synth
only. (tried 1k/.0082 first, worked).
//          spout[1] = 'F';
//          for(tsi = 2; tsi <= 8; tsi++) // Send remaining
7 chars
//          {
//          spout[tsi] = CmdString[tsi - 1];
//          }
//          spout[9] = 0;          // null to terminate
the string if used later by C
//          SPX(6,9);          // ,9 means ,8... fix
later (terminating null is not to be sent)
//          // SPX transmits
to SPI bus
//          PR2 = 0x01;          // Back to normal Baud,
~ 660 kHz/1.5 uS
//          SSPSTAT = 0x40; // Change SPI sequence back to
normal
//          strcpy(StringOut, "\r\n"); // build up a string
to echo
//          strcat(StringOut, CmdString);
//          strcat(StringOut, "\r\n");
//
//          xmit(); // echo back to PC

```

HALO MTP Design Package
 JPL/Caltech PROPRIETARY —Not for Public Release or Redistribution

```

    break;

    case 'I': // "I 10" sends integration cmd to 16F88
integ.
    strcpy(StringOut, "\r\nI");
    n = parscmd(); // parses input$ into
as many #'s as it finds
    n = 3;
    spout[1] = 'I'; // out spi to 16f88
    spout[2] = (char) iarg[0];
    itsave = (char) iarg[0]; // save to put in 'R'
response

    nbytes = n;
    SPX(0, n); // spadd = 0

    btox(iarg[0]);
    strcat(StringOut, hex);
    strcat(StringOut, "\r\n");
    xmit();
    //report(nbytes);
    break;

    case 'M': // read eng. mux iarg[0]

    strcpy(StringOut, "\r\nM");
    n = parscmd(); // parses input$ into
as many #'s as it finds
    btox(iarg[0]);
    strcat(StringOut, hex);
    strcat(StringOut, ":");

    for(mi = 0; mi<8; mi++)
    {
    //select channel
    spout[1] = 0b10001111;
    spout[1] = spout[1] | (mi << 4); // max186
cntrl word includes ch. no.
    // spx goes from spout[1] to...
    spout[2] = 0;
    spout[3] = 0;
    nbytes = 4; //
currently needs nbytes+1
    SPX(iarg[0], nbytes);
    // now right justify to 12 bits
    adcint = spin[1] * 256;
    adcint1 = spin[2];
    adcint = (adcint | adcint1)/8;
    spin[2] = (char) adcint & 0xff;
    adcint = adcint/256;
    spin[1] = (char) adcint & 0x0f;

    lntox(spin[1]); // just the low nibble
is significant

    strcat(StringOut, hex);
    btox(spin[2]);
    strcat(StringOut, hex);

```

HALO MTP Design Package
 JPL/Caltech PROPRIETARY —Not for Public Release or Redistribution

```

    strcat(StringOut, " ");
  }
  strcat(StringOut, "\r\n");
  xmit();
  break;

  case 'N': // Set Noise Diode
On/Off
    strcpy(StringOut, "\r\nND:"); // made "ND" to
dif. from Echo string
    n = parscmd(); // parses input$ into
as many #'s as it finds
    if (iarg[0] == 0)
to zero
        pc= (pc & 0xfe); // Mask portc.0
    else
portc.0 to 1
        pc= (pc | 1); // OR

    PORTC= pc;

    btoc(iarg[0]);
    strcat(StringOut, hex);
    strcat(StringOut, "\r\n");
    xmit();
    break;

  case 'P': // read all 8 Pt mux
mux
    strcpy(StringOut, "\r\nPt:"); // Return full pt
    for(mi = 0; mi<8; mi++)
    {
//select channel
eight addressing
      spout[1] = (1 << mi); // max349 uses one-of-
from spout[1] to...
// spx goes

nbytes = 2; // currently needs nbytes+1
SPX(4, nbytes); // CS 4 = pt mux

// read adc
DelayUs(10);
// read adc
//spout[1] = 144; these 3 for ADC=MAX1272
//spout[2] = 0;
//spout[3] = 0;
ADC MAX1272
      spout[1] = 0; // these 2 for ADC=AD7940
      spout[2] = 0;
ADC AD7940
//SPX(3, 4); // conversion goes into spin[1,2]
      SPX(3, 3); // conversion goes into spin[0,1]

// now right justify to 12 bits (ADC MAX1272)
//adcint = spin[1] * 256;

```

HALO MTP Design Package
 JPL/Caltech PROPRIETARY —Not for Public Release or Redistribution

```

//adcint1 = spin[2] ;
//adcint = (adcinth | adcint1)/8;
//spin[2] = (char) adcint & 0xff;
//adcint= adcint/256;
//spin[1] = (char) adcint & 0x0f;

// now right justify to 14 bits (ADC AD7940)
adcinth = spin[0] * 256;           //      00mb
bbbb

adcint1 = spin[1] ;                //

bbbb bbb1

adcint = (adcinth | adcint1);     // /2;
spin[1] = (char) adcint & 0xff;   // lsb
adcint= adcint/256;
spin[0] = (char) adcint & 0x3f; // msb

btox(spin[0]);                    //

msb first

strcat(StringOut, hex);
btox(spin[1]);                    //

lsb second

strcat(StringOut, hex);
strcat(StringOut, " ");
}
strcat(StringOut, "\r\n");
xmit();
break;

case 'R': // return Integration count, "Rii:" + 3
bytes msb first

strcpy(StringOut, "\r\nR"); // Return Count
n = parscmd(); // get SPI addr into iarg[0]
n = 6; // this is the number

to return incl. "R"

btox(itsave); // get the integration time

last used

strcat(StringOut, hex);
strcat(StringOut, ":");

spout[1] = 'R';
for (cmdi=2; cmdi < n; cmdi++) // for loop
builds up spout[] string
{
  spout[cmdi] = 0; // these are dummy bytes
to push data out of itg.
}
nbytes = n;
SPX(0, n);
for (cmdi = 2; cmdi < (nbytes-1); cmdi++)
{
  btox(spin[cmdi]);
  strcat(StringOut, hex);
}
strcat(StringOut, "\r\n");
xmit();

```

HALO MTP Design Package
JPL/Caltech PROPRIETARY —Not for Public Release or Redistribution

```
break;

case 'S': // return status; rc0 =
datardy rc2 = bias enable
strcpy(StringOut, "\r\nST:"); // made "ST" to
dif. from Echo string
btoc(PORTA & 0b00000111); // was portc til
06/10/16 rfd
strcat(StringOut, hex);
strcat(StringOut, "\r\n");
xmit();
break;

case 'U': // String to Stepper
UART
strcpy(StringOut, "\r\nU:");
strcat(StringOut, CmdString);
strcat(StringOut, "\r\n");
xmit(); // send echo etc. to PC
//
strcpy(StringOut, "Step:");
toUART(); // send cmdstring to Stepper UART
//xmit(); // diagnostic
frUART(); // Get Stepper response strcat'd to
StringOut
//strcat(StringOut, "!"); //diagnostic
//xmit();
strcat(StringOut, "\r\n");
xmit();
break;

case 'V': // version date
strcpy(StringOut, "\r\nVersion:");
strcat(StringOut, version);
xmit();
break;

case 'X': // "X 01 dd ddd d" sends dec. numbers
byte by byte to SPI 1
n = parscmd(); // parses
input$ into as many #'s asit finds
for (cmdi=1; cmdi < n; cmdi++) // for loop
builds up spout[] string
{
spout[cmdi] =(char) iarg[cmdi];
btoc(spout[cmdi]);
// conv to hex$
}
nbytes = n;
SPX(iarg[0], n); // first number after "X" =
spadd

report(nbytes);

break;
```

HALO MTP Design Package
JPL/Caltech PROPRIETARY —Not for Public Release or Redistribution

```
        default:
            strcpy(StringOut, "\r\nUnknown cmd\r\n");
            xmit();
            break;
    }

    cmdRdy = 0;
    //while(strlen(StringOut) > 4); // wait here for
buffer to be sent
    strcat(StringOut, CmdString); // this prints out the
last command
    }

} // endwhile
//*****
} // End of Mainline
// |
```

19 MTP Mechanical Drawings

The following mechanical drawings provide the dimension and materials used for manufacturing most of the MTP-H parts. However, many small parts, such as connector mounting brackets, are not provided, as they were made on an ad hoc basis. The drawings are numbered 67708MTP-01 through 67708MTP-53, but only 39 drawings are provided; that is, there were no drawings corresponding to some numbers, for example, 67708MTP-34 through -39. All of the aluminum parts are 6061-T6 except for part number 67708MTP-10, the Electronics Base Plate, which is 7075-T7351. All parts have a protective iridite finish meeting Mil-C 5541, Type 1A. A list of part numbers and part description (in the form of the SolidWorks filename) is provided on the following page. It is recognized that it may not be possible to read the dimension and other details on some of the drawings. In that case the reader should use of free viewer program such as eDrawings Viewer:

<http://www.solidworks.com/sw/products/free-cad-software-downloads.htm>

so that they can zoom in on the relevant information in the SolidWorks files, which are available separately. Note that the SolidWorks files are UCAR and JPL/Caltech proprietary. The main reason for showing the drawings here is so that the reader will know what is available.

HALO MTP Design Package
JPL/Caltech PROPRIETARY —Not for Public Release or Redistribution

Part No	File Name
67708MTP-01	Scanner Cover
67708MTP-02	Attach Fitting.SLDDRW (Guess)
67708MTP-03	Window.SLDDRW
67708MTP-04	Base Plate-C.SLDDRW
67708MTP-05	Interface Plate.SLDDRW
67708MTP-06	Upper Brace
67708MTP-07	Lower Brace
67708MTP-08	Fairing Half.SLDDRW
67708MTP-09	Attach Block.SLDDRW
67708MTP-10	Electronic Base Plate
67708MTP-11	Electronic Enclosure Bottom Plate.SLDDRW
67708MTP-12	Electronic Enclosure Top Plate.SLDDRW
67708MTP-13	Electronics Pack.SLDDRW
67708MTP-14	Idler Spacer, Thick.SLDDRW
67708MTP-15	Idler Spacer, Thin.SLDDRW
67708MTP-16	Idler Spacer, Thin, Small Hole.SLDDRW
67708MTP-17	Sprocket, Modified EM5-20 Idler.SLDDRW
67708MTP-18	Modified .25 x .125 Shoulder Screw.SLDDRW
67708MTP-19	Tensioner Arm.SLDDRW
67708MTP-20	RF Plate, MTP-H-11000-ASSY.SLDDRW
67708MTP-21	Bulkhead Support.SLDDRW
67708MTP-22	Connecting Plate.SLDDRW
67708MTP-23	Electronics Box Insulator.SLDDRW
67708MTP-24	Electronics Shelf Insulator.SLDDRW
67708MTP-25	Forward Compartment Standoff.SLDDRW
67708MTP-26	Idler Spacer, Upper.SLDDRW
67708MTP-27	Idler Spacer.SLDDRW
67708MTP-28	Motor Mounting Block.SLDDRW (Guess)
67708MTP-29	Position Sensor Bracket.SLDDRW
67708MTP-30	Power Supply Sub-Plate.SLDDRW
67708MTP-31	Rear Compartment Rod.SLDDRW (4)
67708MTP-32	Sensor Flag.SLDDRW
67708MTP-33	Source Bracket, Single.SLDDRW
	PMS Rear Bulkhead.SLDPRT
67708MTP-40	PMS Rear Bulkhead.SLDDRW
	Stepper Base.SLDPRT
67708MTP-41	Stepper Base.SLDDRW
	RF Enclosure Assembly.SLDASM
67708MTP-50	MTP-H-10008-PRT-1.SLDDRW
67708MTP-51	RF Enclosure Rear End Plate V2-1.SLDDRW
67708MTP-52	RF Enclosure Front End Plate V2-1.SLDDRW

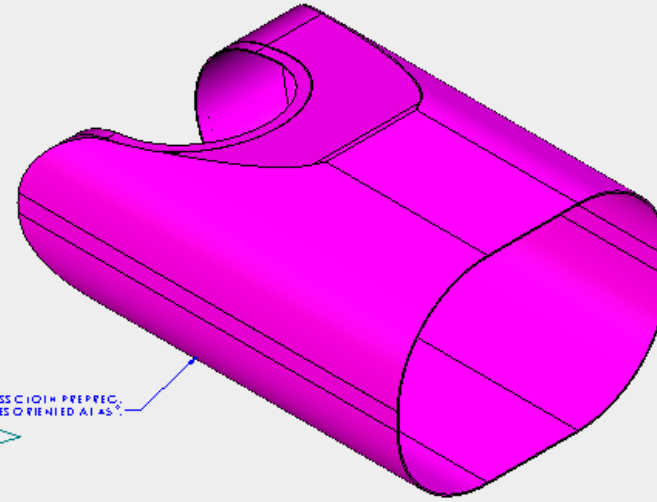
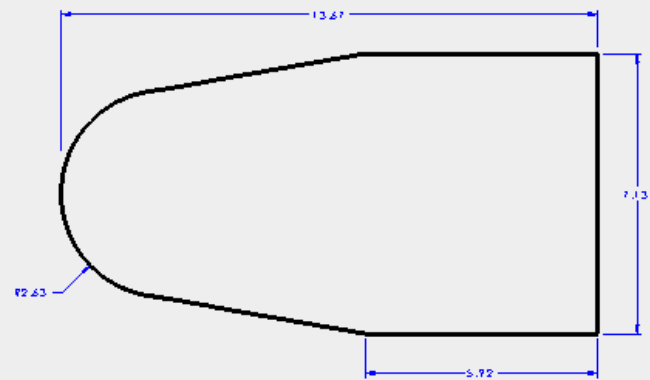
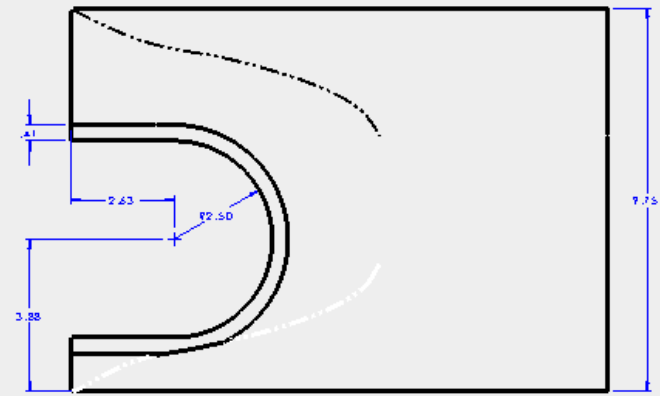

11M22/C101 D3 HB EFC CLASS C101H PREPREG,
 7 FILLS ORIENTED AT 45°

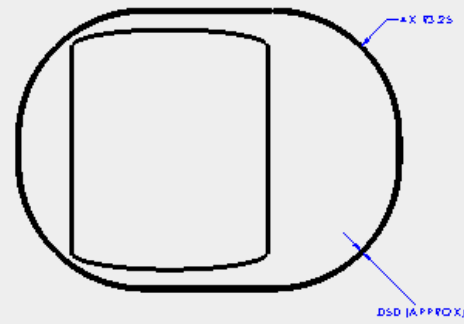

NOTES:

1. PRODUCTION: ADVANCED COMPOSITES GROUP 1815A 067413A

PROPRIETARY AND CONFIDENTIAL
 THIS DRAWING IS THE PROPERTY OF CALTECH AND JPL. IT IS TO BE USED ONLY FOR THE PURPOSES SPECIFIED HEREIN. NO PART OF THIS DRAWING IS TO BE REPRODUCED OR TRANSMITTED IN ANY FORM OR BY ANY MEANS, ELECTRONIC OR MECHANICAL, INCLUDING PHOTOCOPYING, RECORDING, OR BY ANY INFORMATION STORAGE AND RETRIEVAL SYSTEM, WITHOUT THE EXPRESS WRITTEN PERMISSION OF CALTECH AND JPL. THIS DRAWING IS UNCLASSIFIED.

ITEM	PART NO.	DESCRIPTION	MATERIAL	SPECIFICATION	WT.
	-01	COVER	SEE F/D		
<p>APPROVALS</p> <p>DR. <i>[Signature]</i> DATE 010808</p> <p>ENR. J HOX DSDSE</p> <p>CHK. <i>[Signature]</i></p> <p>APPD.</p> <p>EFFEKTIV</p>					
<p>DO NOT SCALE DRAWING</p> <p>NEXT ASSEMBLY</p>					
<p>SCALE 1:2</p>			<p>SHEET 1 OF 1</p>	<p>REV. A</p>	<p>DATE 05EF8</p>
<p>67708MTP-01</p>					

HIAPER

SCANNER COVER

MTP-H

67708MTP-01

1 OF 1

C

B

A

4

3

2

1

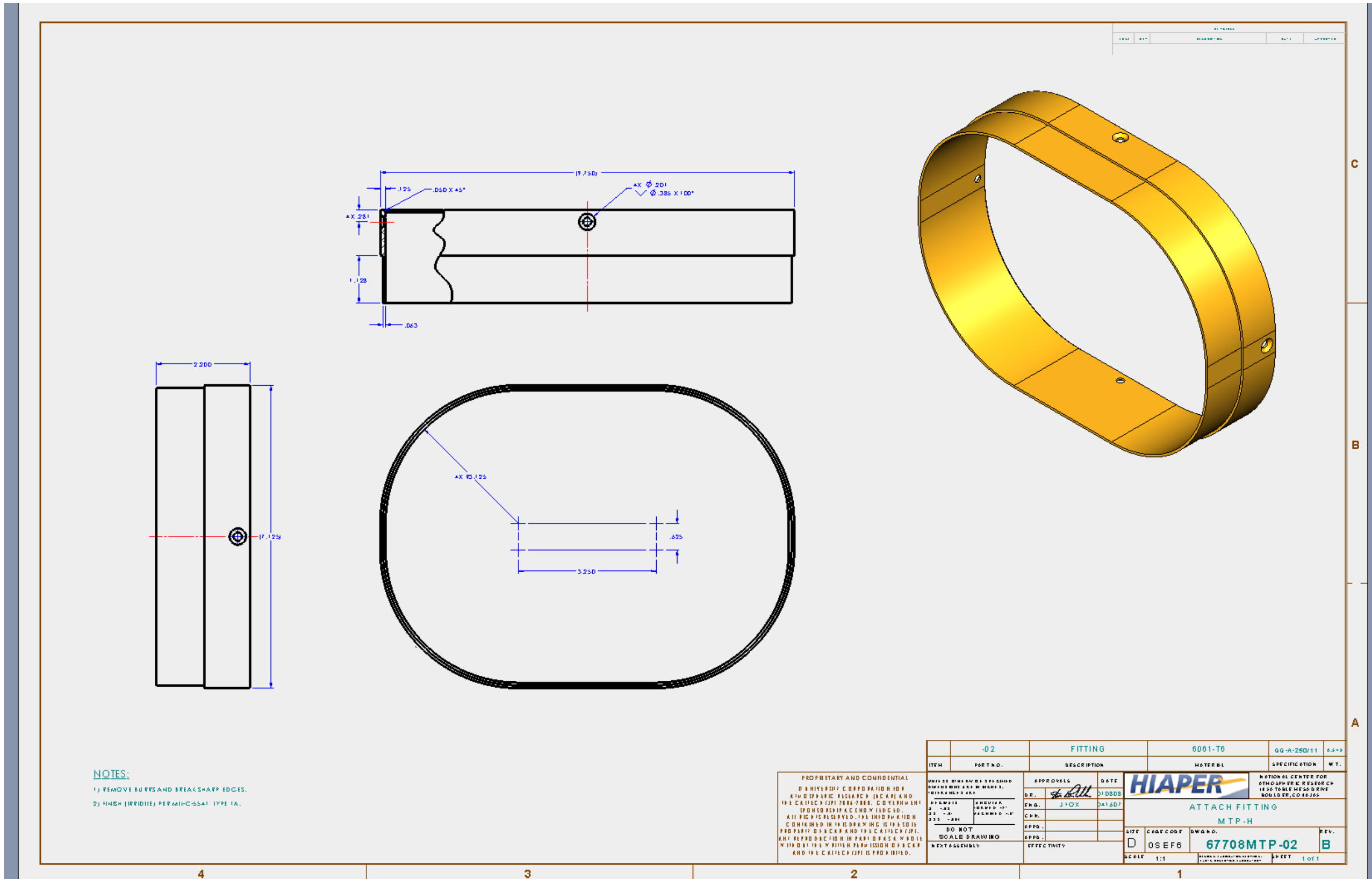

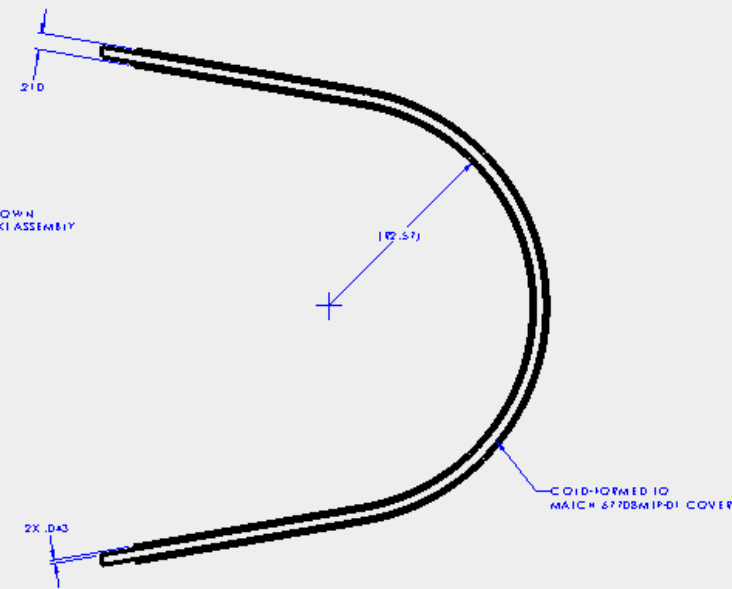
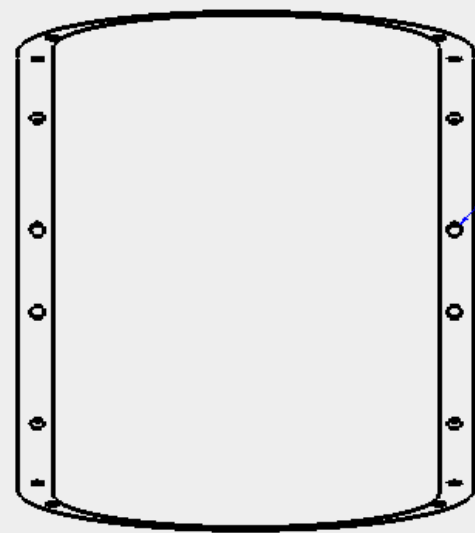
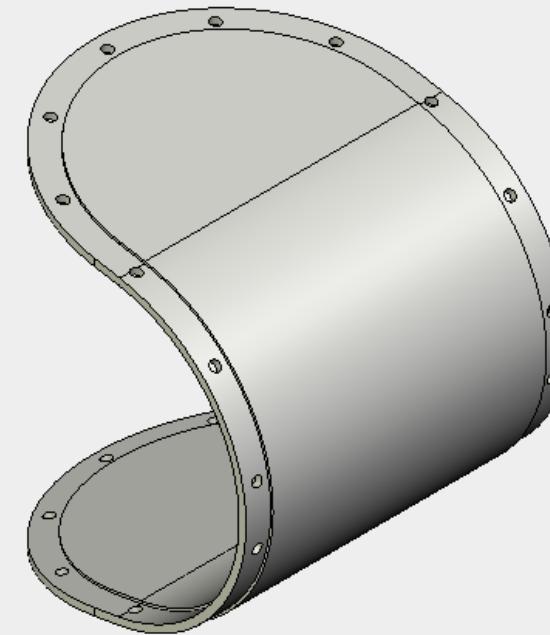
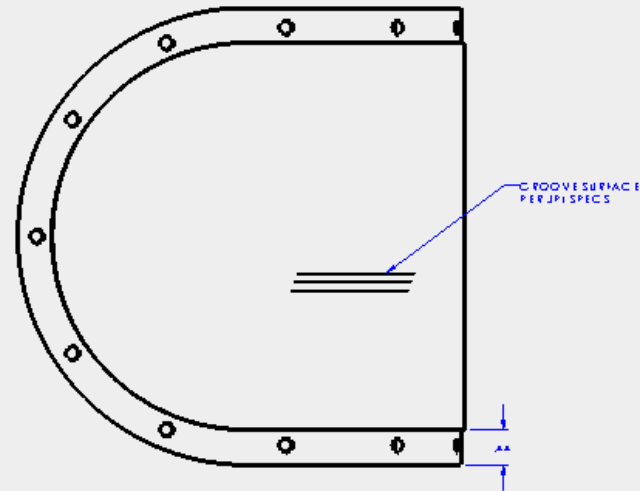
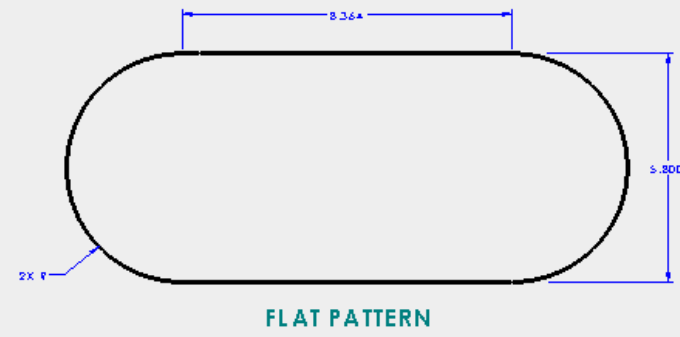

-03		WINDOW	PE High Density	6.561
REV	PART NO.	DESCRIPTION	MATERIAL	SPECIFICATION
PROPRIETARY AND CONFIDENTIAL		APPROVALS	DATE	NETIONAL CENTER FOR
DRAWING		DR.	010808	ATMOSPHERIC RESEARCH
REV. 01		ENG. JHX	031606	1550 TOWNSEND DRIVE
REV. 02		CPR.		SOLEDER, CA 94035
REV. 03		APPD.		
REV. 04		EFFECTIVE		
DO NOT SCALE DRAWING		SITE CASE CODE		REV.
EXT ASSEMBLY		0SEF8		B
		DRAWING NO. 67708MTP-03		
		SCALE 1:1		SHEET 1 OF 1

4

3

2

1

C

B

A

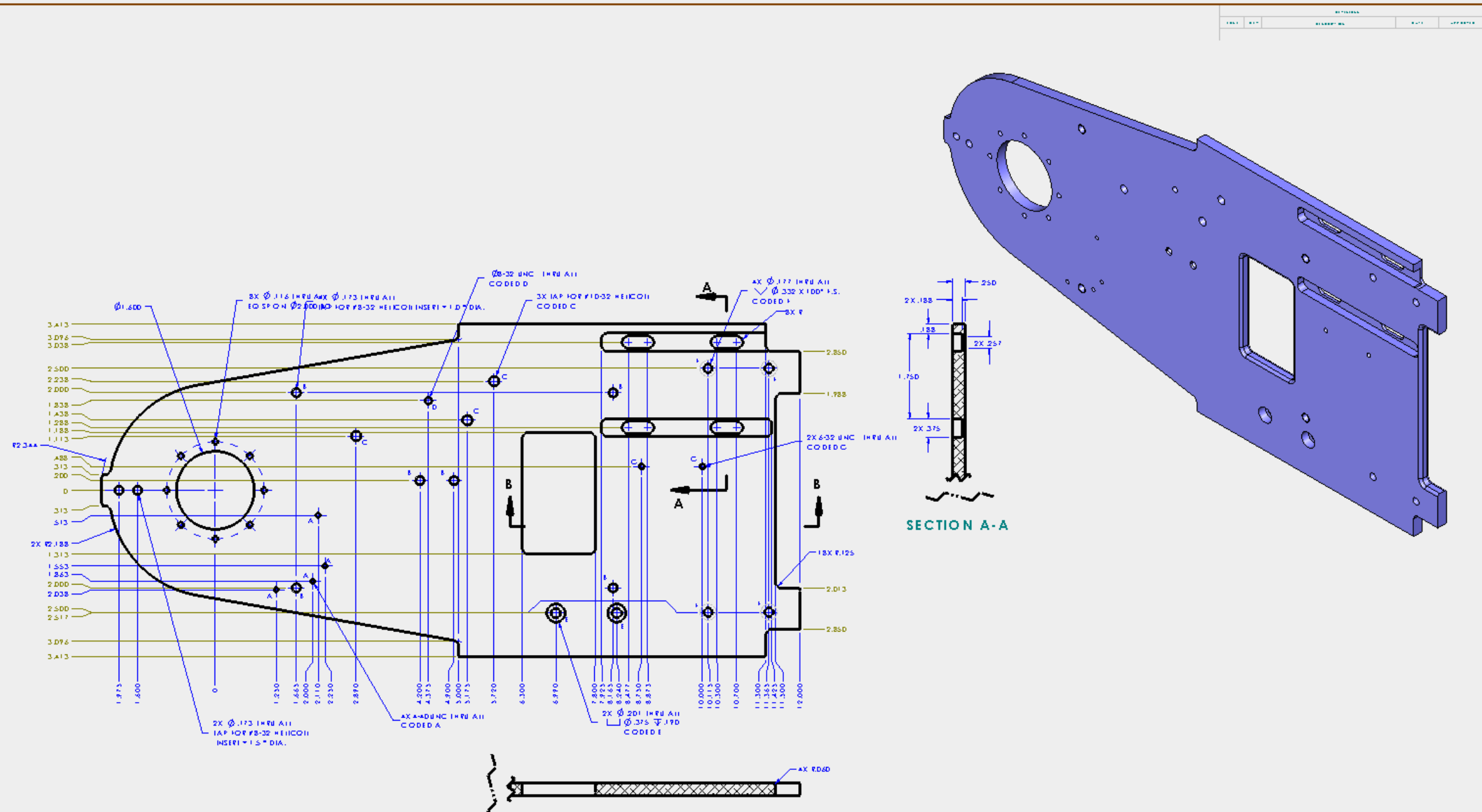

- NOTES:**
- 1) REMOVE BURRS AND BREAK SHARP EDGES.
 - 2) FINISH (IF APPLICABLE) PER MIL-C-5541 TYPE 1A.

PROPRIETARY AND CONFIDENTIAL
 THIS DRAWING IS THE PROPERTY OF JPL/Caltech PROPRIETARY AND NOT FOR PUBLIC RELEASE OR REDISTRIBUTION. ALL RIGHTS ARE RESERVED. THE INFORMATION CONTAINED HEREIN IS UNCLASSIFIED EXCEPT WHERE SHOWN OTHERWISE. THE INFORMATION CONTAINED HEREIN IS UNCLASSIFIED EXCEPT WHERE SHOWN OTHERWISE.

REV	DATE	DESCRIPTION	BY	CHKD
04		PLATE		
		6061-T6		
		Q0-A-250111		
		1.729		
PROPRIETARY AND CONFIDENTIAL THIS DRAWING IS THE PROPERTY OF JPL/Caltech PROPRIETARY AND NOT FOR PUBLIC RELEASE OR REDISTRIBUTION. ALL RIGHTS ARE RESERVED. THE INFORMATION CONTAINED HEREIN IS UNCLASSIFIED EXCEPT WHERE SHOWN OTHERWISE. THE INFORMATION CONTAINED HEREIN IS UNCLASSIFIED EXCEPT WHERE SHOWN OTHERWISE.		DATE: 010908 D.W.: JHX D31606		HIAPER BASE PLATE-C MTP-H
DO NOT SCALE DRAWING	REV	DATE	DESCRIPTION	BY
	D	05EF8	67708MTP-04	C
		1:1		1:012

IAC	XIQC	YIQC	SEE
A1	1.25D	-2.037	ØA-ADUNC IHRU
A2	2.00D	-1.862	ØA-ADUNC IHRU
A3	2.11D	-.812	ØA-ADUNC IHRU
A4	2.25D	-1.552	ØA-ADUNC IHRU
E1	1.665	-2.00D	Ø1/2-28UNF IHRU
E2	1.665	2.00D	Ø1/2-28UNF IHRU
E3	4.50D	2DD	Ø1/2-28UNF IHRU
E4	4.70D	2DD	Ø1/2-28UNF IHRU
E5	3.165	-2.00D	Ø1/2-28UNF IHRU
E6	3.165	2.00D	Ø1/2-28UNF IHRU
C1	2.39D	1.113	IAP IOT F1D-32 HEICOH
C2	5.175	1.438	IAP IOT F1D-32 HEICOH
C3	5.72D	2.238	IAP IOT F1D-32 HEICOH
D1	4.375	1.838	Ø-32UNC IHRU
E1	4.72D	-2.517	Ø2DI IHRU I Ø37D Φ.17D
E2	3.24D	-2.517	Ø2DI IHRU I Ø37D Φ.17D
H	1D.115	-2.50D	Ø.177 Ø.332 X10D*15
I2	1D.115	2.50D	Ø.177 Ø.332 X10D*15
I3	11.465	-2.50D	Ø.177 Ø.332 X10D*15
I4	11.37	2.50D	Ø.177 Ø.332 X10D*15
C1	8.75	47	Ø-32UNC IHRU
C2	1D.0D	47	Ø-32UNC IHRU

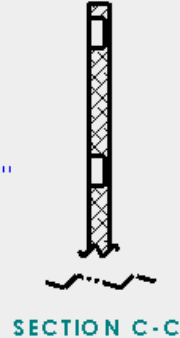
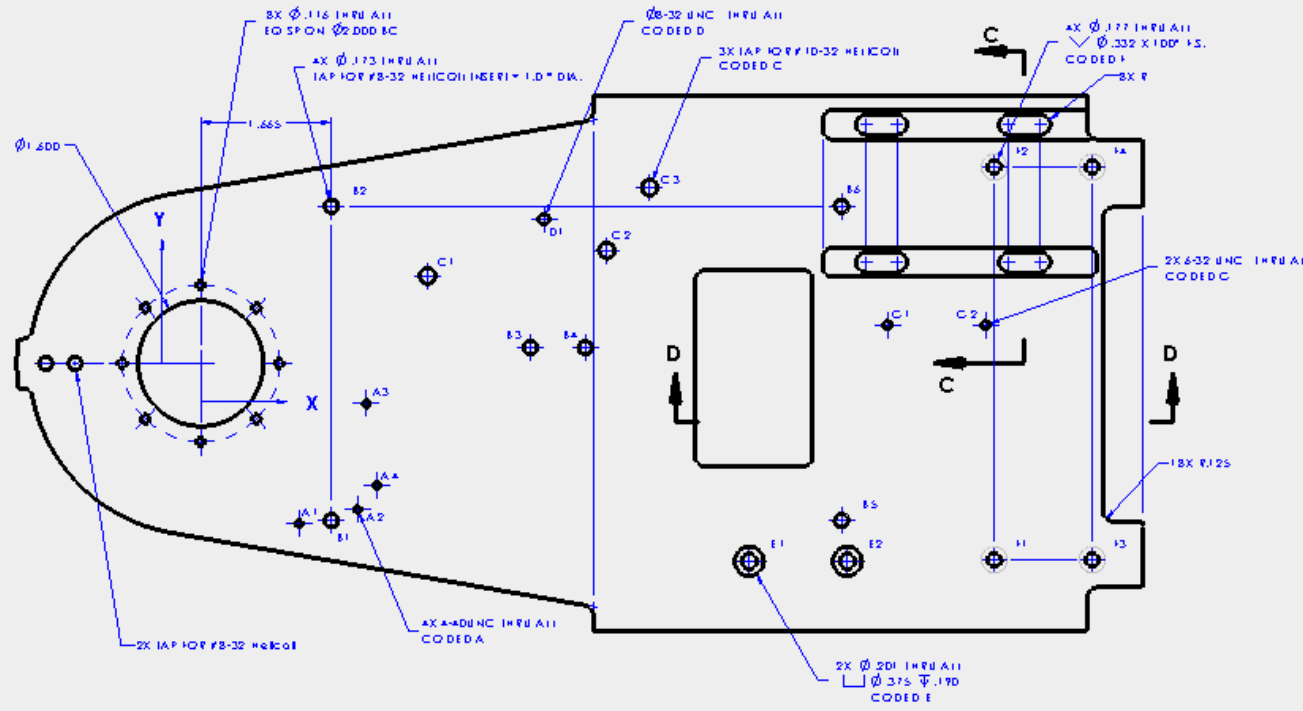

ALL DIMENSIONS FOR REFERENCE ONLY

ALL

REV	DATE	DESCRIPTION	BY	APPR
1				

REV	DATE	DESCRIPTION	BY	APPR
D	05EF6	67708MTP-10		C
SCALE	1:1	TOTAL NUMBER OF SHEETS	REV	2 of 2

4

3

2

1

C
B
A

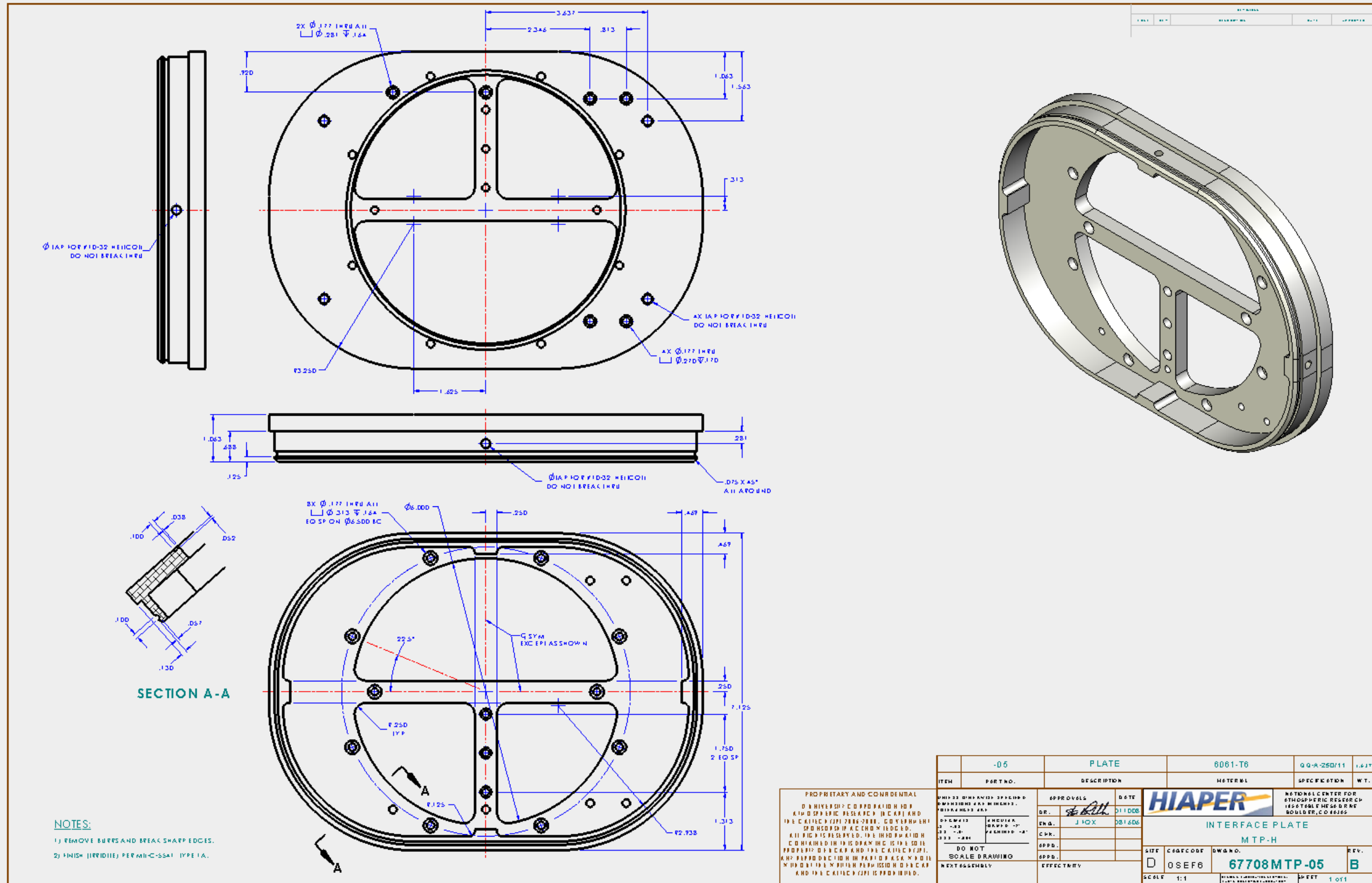

ITEM	PART NO.	DESCRIPTION	MATERIAL	SPECIFICATION	WT.
	-05	PLATE	6061-T6	QQ-A-250/11	1.637

APPROVALS	DATE
DR. <i>[Signature]</i>	01/08
ENR. J. H. OX	08/16/06
CHK. [Signature]	
OPFD. [Signature]	
EFFECTIVE	

SUPP.	CAGE CODE	DWG. NO.	REV.
D	0SEF6	67708MTP-05	B

SCALE 1:1

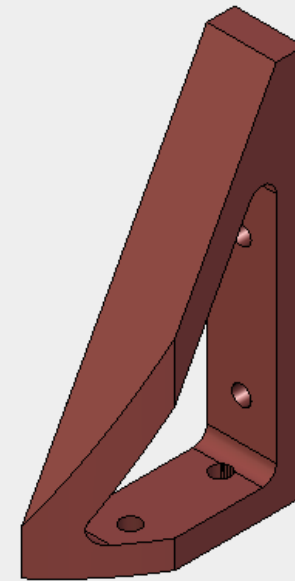
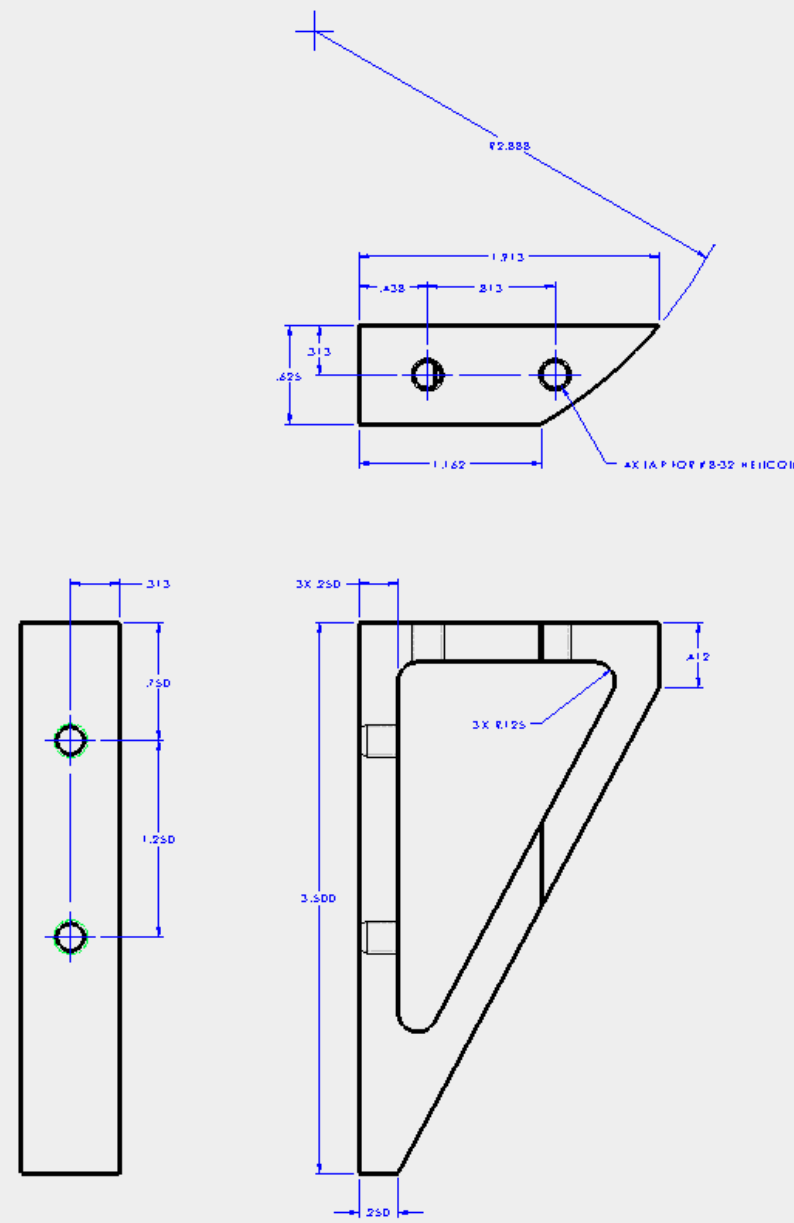

NOTES:
 1) REMOVE BURRS AND BREAK SHARP EDGES.
 2) FINISH (FRTDIE) PER MIL-C-8841 TYPE 1A.

ITEM	PART NO.	DESCRIPTION	MATERIAL	SPECIFICATION	WT.
	-06	BRACE	Material <not specified>	QQ-A-250/11	6.117

PROPRIETARY AND CONFIDENTIAL THIS DRAWING IS THE PROPERTY OF CALTECH AND IS NOT TO BE REPRODUCED OR TRANSMITTED IN ANY FORM OR BY ANY MEANS, ELECTRONIC OR MECHANICAL, INCLUDING PHOTOCOPYING, RECORDING, OR BY ANY INFORMATION STORAGE AND RETRIEVAL SYSTEM.		APPROVALS DR. <i>[Signature]</i> ENGR. J. HOX CDR. <i>[Signature]</i>	DATE 01/10/06 00206		NATIONAL CENTER FOR OPTICALLY ASSISTED RESEARCH BOULDER, CO 80506
DO NOT SCALE DRAWING NEXT ASSEMBLY EFFECTIVE		UPPER BRACE MTP-H		D 0SEF6 67708MTP-06 A	
SCALE 2:1		SHEET 1 OF 1			

4

3

2

1

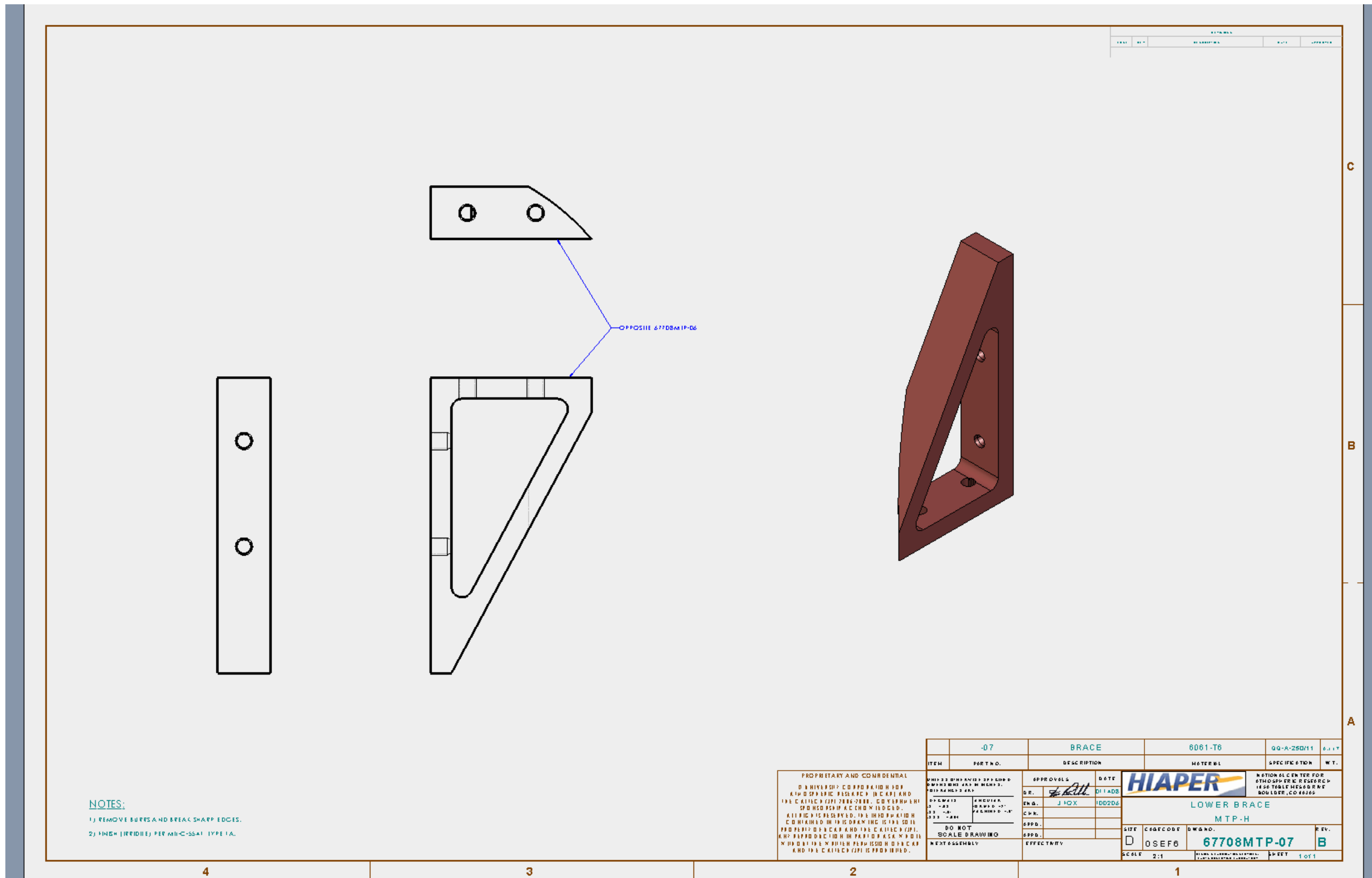

NOTES:
 1) REMOVE BURRS AND BREAK SHARP EDGES.
 2) FINISH (FRRDIE) PER MIL-C-8831 TYPE 1A.

PROPRIETARY AND CONFIDENTIAL
 THIS DRAWING IS THE PROPERTY OF CALTECH AND JPL. IT IS TO BE USED ONLY FOR THE PURPOSES SPECIFIED IN THE DRAWING. IT IS NOT TO BE REPRODUCED, COPIED, OR TRANSMITTED IN ANY FORM OR BY ANY MEANS, ELECTRONIC OR MECHANICAL, INCLUDING PHOTOCOPYING, RECORDING, OR BY ANY INFORMATION STORAGE AND RETRIEVAL SYSTEM. ANY UNAUTHORIZED REPRODUCTION OR USE OF THIS DRAWING IS PROHIBITED.

ITEM	PART NO.	DESCRIPTION	MATERIAL	SPECIFICATION	WT.
	-07	BRACE	6061-T6	QQ-A-250/11	0.117

APPROVALS	DATE	 JPL/Caltech Center for High Power Laser Research Boulder, CO 80506
DR. <i>[Signature]</i>	01/14/08	
ENR. J. HOX	00206	
CHK. [Signature]		
APPD.		
DO NOT SCALE DRAWING		
NEXT ASSEMBLY		
EFFECTIVE		

SHEET	CASE CODE	DWG NO.	REV.
D	0SEF6	67708MTP-07	B
SCALE	2:1	SHEET	1 of 1

4

3

2

1

C

B

A

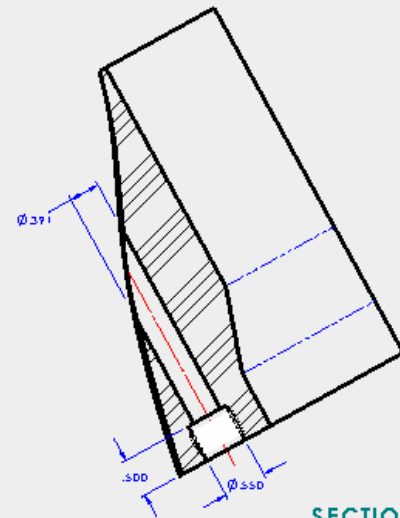
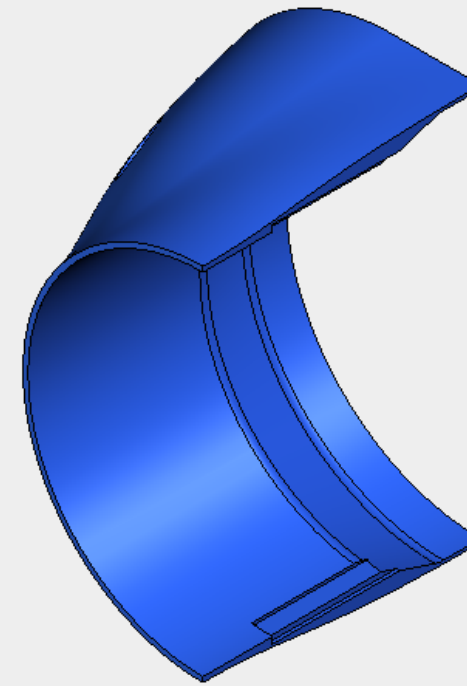
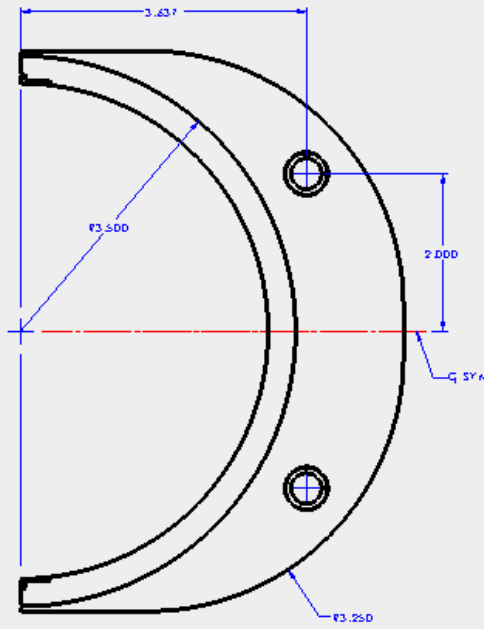
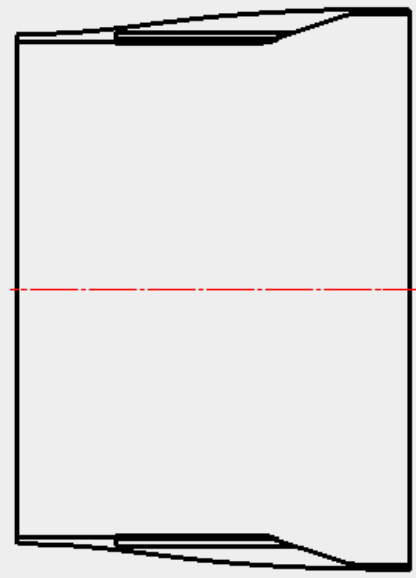
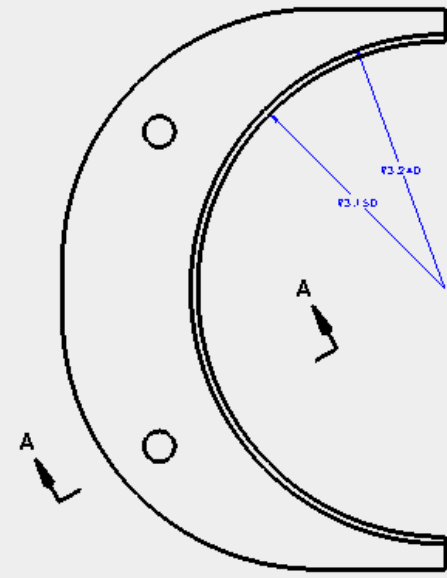

NOTE:
 DIMENSIONS SHOWN ARE FOR REFERENCE ONLY.
 PART TO BE MANUFACTURED BY RAPID PROTOTYPE
 USED DEPOSITION METHOD. SPARSE IF AVAILABLE
 IN 30% ABS MATERIAL. PART TO BE CREATED USING
 CAD FILE TP FAIRING - A11510.PRT

NOTES:

- 1) REMOVE BURRS AND BREAK SHARP EDGES.
- 2) FINISH (IRRIDITE) PER MIL-C-5541 TYPE I.A.

SECTION A-A

PROPRIETARY AND CONFIDENTIAL
 THIS DOCUMENT CONTAINS INFORMATION FOR
 THE CALTECH/JPL 2000-2001. CONFIDENTIALITY
 IS MAINTAINED IN THIS DRAWING. IT IS TO BE
 USED ONLY FOR THE PURPOSES SPECIFIED IN THE
 DRAWING. IT IS NOT TO BE REPRODUCED OR
 TRANSMITTED IN ANY FORM OR BY ANY MEANS
 WITHOUT THE EXPRESS PERMISSION OF JPL AND
 THE CALTECH/JPL IS PROHIBITED.

ITEM	PART NO.	DESCRIPTION	MATERIAL	SPECIFICATION	WT.
	-08	FAIRING	ABS		
<p>APPROVALS: <i>[Signature]</i> DATE: 01/14/08</p> <p>ENG: SJR 082007</p> <p>CHK: []</p> <p>APPD: []</p> <p>EFFE: []</p>					
<p>DO NOT SCALE DRAWING</p> <p>NEXT ASSEMBLY</p>			<p>SCALE: 1:1</p>		
<p>SIFF: D</p> <p>CASE CODE: 0SEF6</p>		<p>DWG NO: 67708MTP-08</p>		<p>REV: A</p>	
<p>SCALE: 1:1</p> <p>DATE: 01/14/08</p> <p>BY: SJR</p> <p>CHK: []</p> <p>APPD: []</p> <p>EFFE: []</p>					

4

3

2

1

HALO MTP Design Package
 JPL/Caltech PROPRIETARY —Not for Public Release or Redistribution

REVISIONS			
NO.	DATE	DESCRIPTION	BY

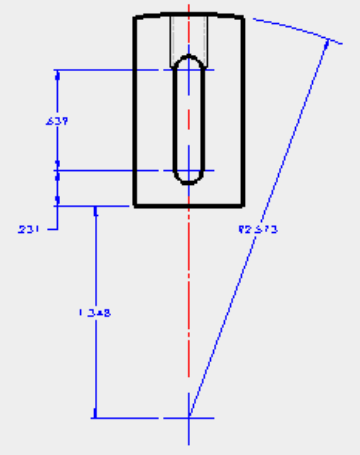
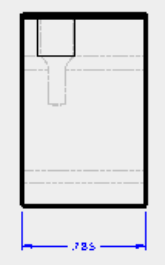
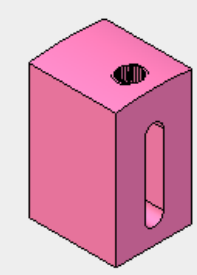
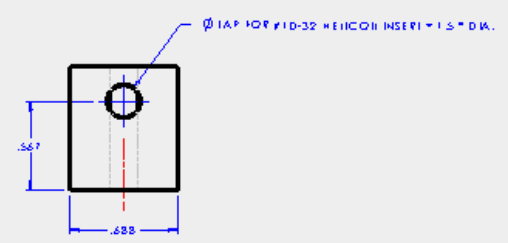

NOTES:
 1) REMOVE BURRS AND BREAK SHARP EDGES.
 2) FINISH (FRTDIE) PER MIL-C-8831 TYPE 1A.

-09		BLOCK	8061-T6	QQ-A-250/11	4.663
ITEM	PART NO.	DESCRIPTION	MATERIAL	SPECIFICATION	WT.
<p>PROPRIETARY AND CONFIDENTIAL THIS DRAWING IS THE PROPERTY OF CALTECH AND JPL. IT IS TO BE USED ONLY FOR THE PURPOSES SPECIFIED HEREIN. IT IS NOT TO BE REPRODUCED, COPIED, OR TRANSMITTED IN ANY FORM OR BY ANY MEANS, ELECTRONIC OR MECHANICAL, INCLUDING PHOTOCOPYING, RECORDING, OR BY ANY INFORMATION STORAGE AND RETRIEVAL SYSTEM, WITHOUT THE EXPRESS WRITTEN PERMISSION OF CALTECH AND JPL.</p>					
APPROVALS DR. <i>[Signature]</i> ENGR. J. HOX CHK. <i>[Signature]</i>		DATE 01/15/08 11/26/07			
ATTACH BLOCK MTP-H					
DO NOT SCALE DRAWING NEXT ASSEMBLY EFFECTIVE		D 0SEF6 SCALE 2:1		DWG NO. 67708MTP-09 SHEET 1 of 1	

4

3

2

1

C

B

A

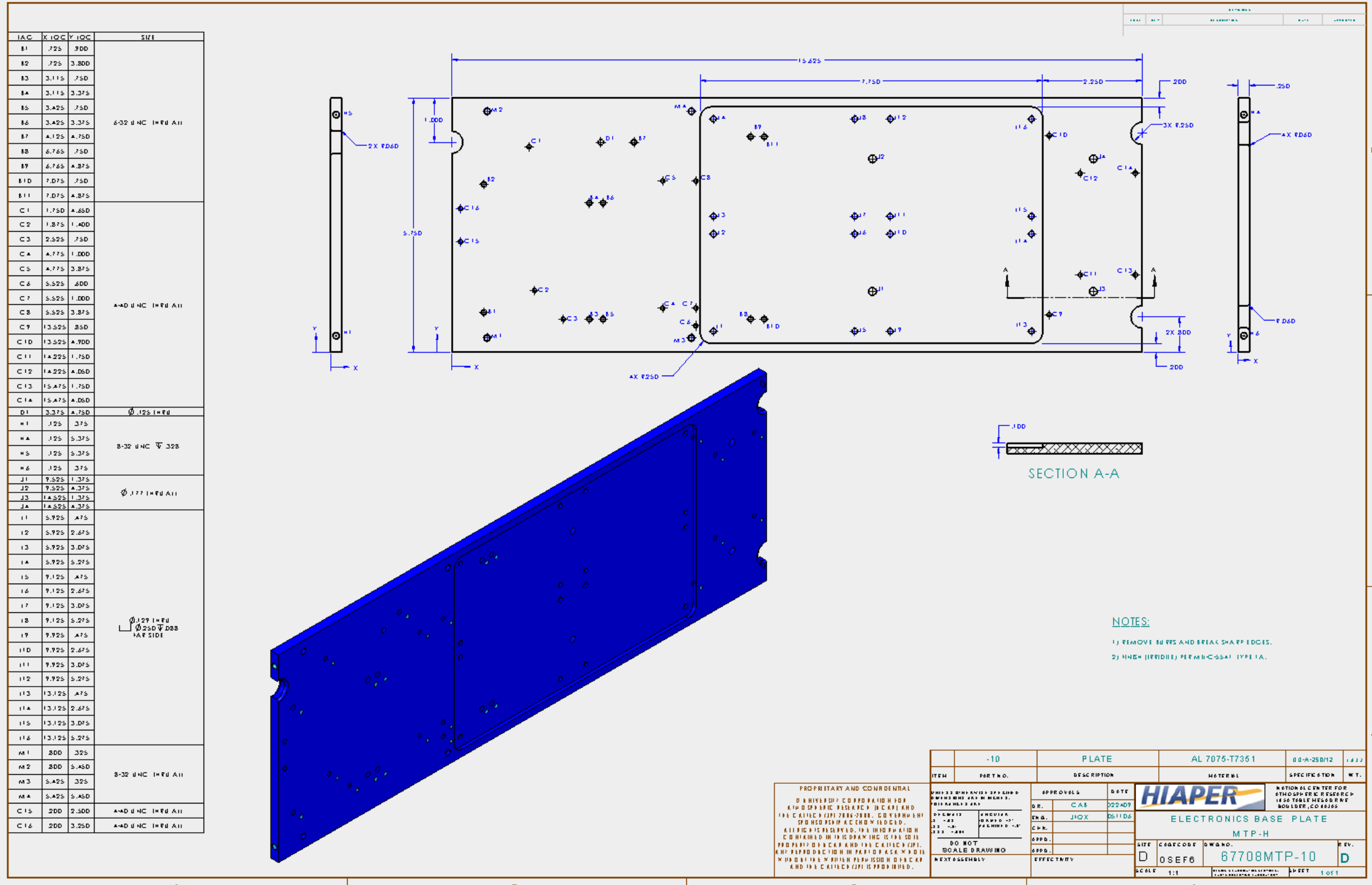

IAC	X IOC	Y IOC	SIZE	
B1	.725	.900	6-32 UNC 1HRU A11	
B2	.725	3.800		
B3	3.115	.750		
B4	3.115	3.375		
B5	3.425	.750		
B6	3.425	3.375		
B7	4.125	4.750		
B8	6.765	.750		
B9	6.765	4.875		
B10	7.075	.750		
B11	7.075	4.875		
C1	1.750	4.650	4-40 UNC 1HRU A11	
C2	1.875	1.400		
C3	2.525	.750		
C4	4.775	1.000		
C5	4.775	3.875		
C6	5.525	.600		
C7	5.525	1.000		
C8	5.525	3.875		
C9	13.525	.850		
C10	13.525	4.700		
C11	14.225	1.750		
C12	14.225	4.050		
C13	15.475	1.750		
C14	15.475	4.050		
D1	3.375	4.750	Ø .125 1HRU	
H1	.125	.375	8-32 UNC 328	
H4	.125	5.375		
H5	.125	5.375		
H6	.125	.375		
J1	9.525	1.375		Ø .177 1HRU A11
J2	9.525	4.375		
J3	14.525	1.375		
J4	14.525	4.375		
I1	5.925	.475	Ø .129 1HRU Ø .250 328 DBS 1/8" SIDE	
I2	5.925	2.675		
I3	5.925	3.075		
I4	5.925	5.275		
I5	9.125	.475		
I6	9.125	2.675		
I7	9.125	3.075		
I8	9.125	5.275		
I9	9.925	.475		
I10	9.925	2.675		
I11	9.925	3.075		
I12	9.925	5.275		
I13	13.125	.475		
I14	13.125	2.675		
I15	13.125	3.075		
I16	13.125	5.275		
M1	.800	.325	8-32 UNC 1HRU A11	
M2	.800	5.450		
M3	5.425	.325		
M4	5.425	5.450	4-40 UNC 1HRU A11	
C15	.200	2.500		
C16	.200	3.250		

NOTES:
 1) REMOVE BURRS AND BREAK SHARP EDGES.
 2) HNEH (IRRIDIE) PER MIL-C-5541 TYPE 1A.



ITEM	PART NO.	DESCRIPTION	MATERIAL	SPECIFICATION	WT.
	-10	PLATE	AL 7075-T7351	80-A-250/12	1.432

PROPRIETARY AND CONFIDENTIAL JPL/Caltech Research in California and the California State University System is hereby acknowledged.		APPROVALS DR. CAE ENR. JHOX CWR.	DATE 022409 051106	ELECTRONICS BASE PLATE MTP-H	ACTION CENTER FOR OTHER CALTECH RESEARCH 1550 TABLE MESA BLVD BERKELEY, CA 94720
DO NOT SCALE DRAWING NEXT ASSEMBLY		EFFECTIVE	DIFF. CASE CODE D 0SEF6		DWG NO. 67708MTP-10

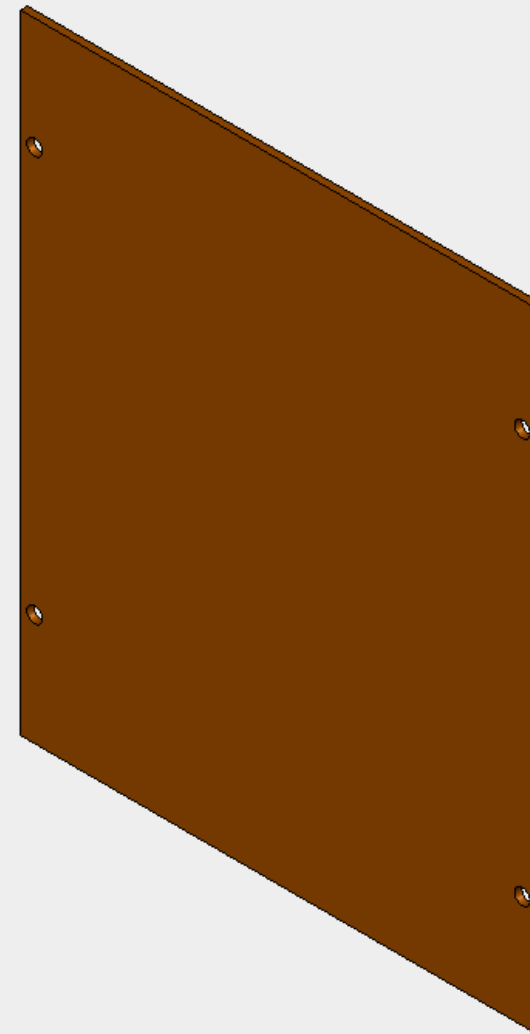
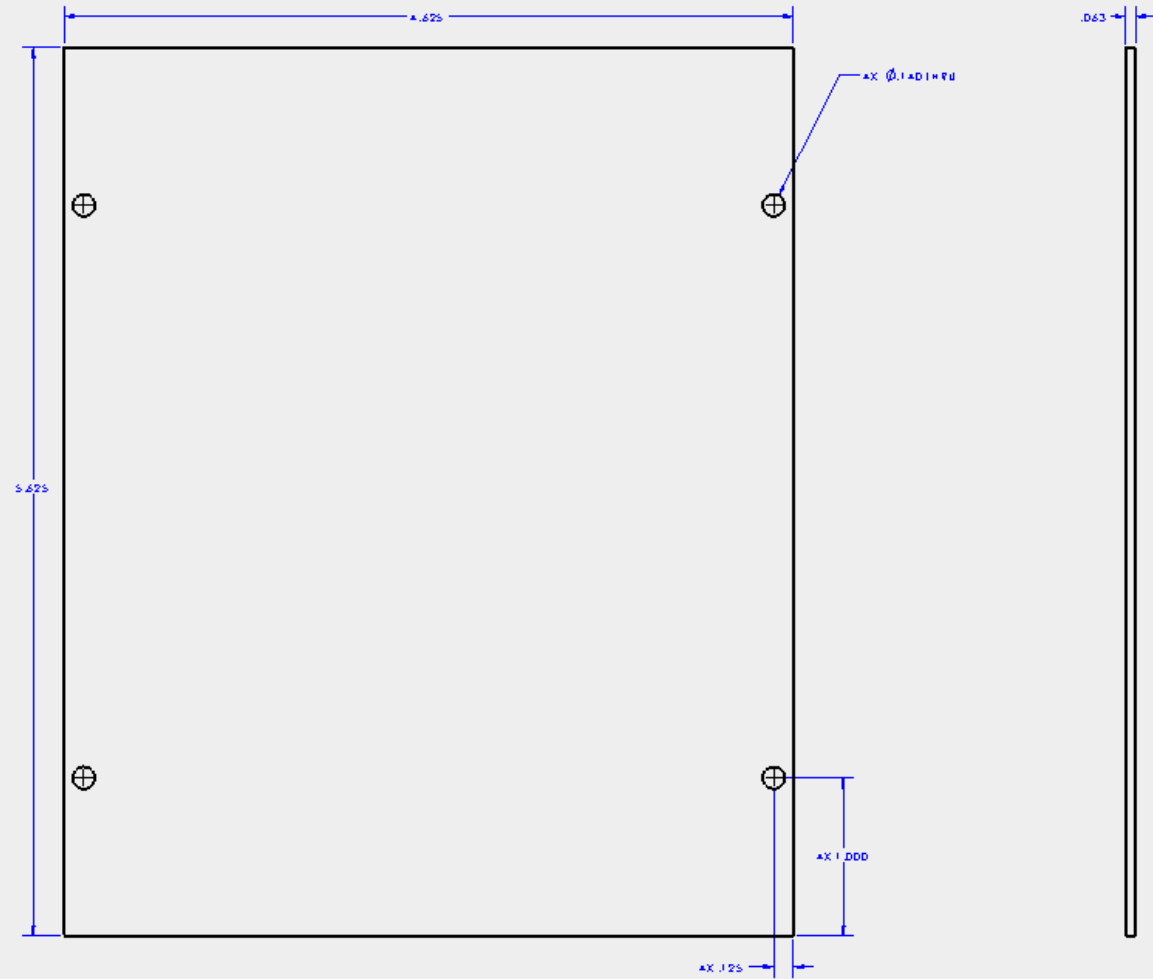

NOTES:

- 1) REMOVE BURRS AND BREAK SHARP EDGES
- 2) FINISH/HEAT TREAT

PROPRIETARY AND CONFIDENTIAL
 UNIVERSITY OF CALIFORNIA
 JPL/Caltech PROPRIETARY —Not for Public Release or Redistribution

ITEM	PART NO.	DESCRIPTION	MATERIAL	SPECIFICATION	W.T.
-11		PLATE, ELECTRONIC ENCLOSURE BOTTOM			
APPROVALS DR: CAE 022407 ENR: JHX 031307 CHK: APPD: EFFECTIVE		DATE 022407 031307		H I A P E R ELECTRIC ENCLOSURE BOTTOM PLATE MTP-H	
DO NOT SCALE DRAWING NEXT ASSEMBLY		SIZE: D CODE CODE: 0SEF6 SCALE: 2:1	DWG NO.: 67708MTP-11	REV: A SHEET 1 OF 1	

4

3

2

1

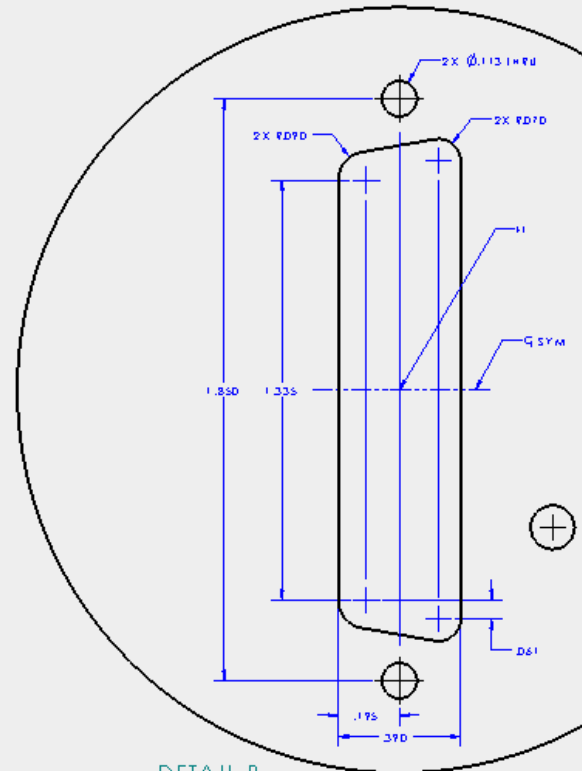
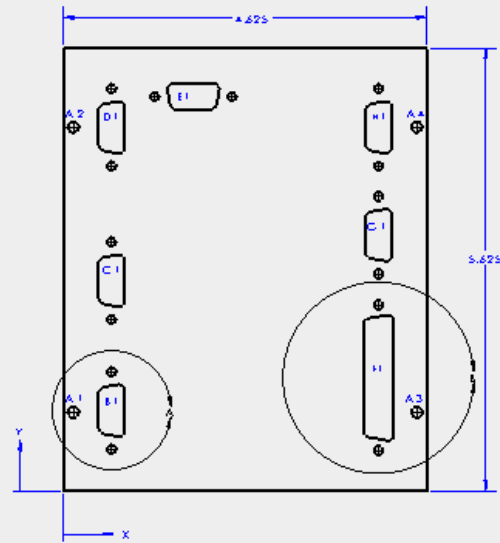

DETAIL B
SCALE 4 : 1

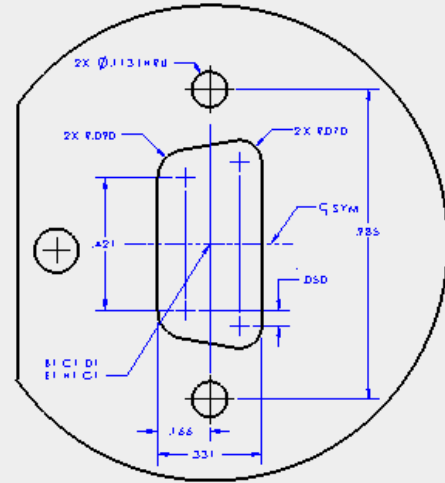

DETAIL A
SCALE 4 : 1
6 LOCATIONS

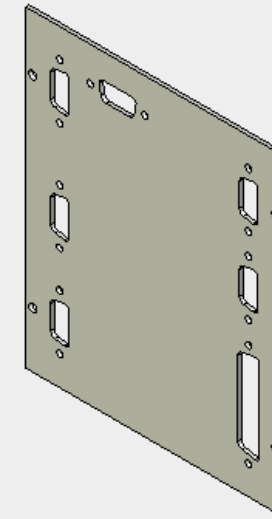

- NOTES:
 1) REMOVE BURRS AND BREAK SHARP EDGES
 2) HANG/HEAT TREAT

IAC	X IOC	Y IOC	SIZE
A1	.125	1.000	Ø.1131H98
A2	.125	4.625	
A3	4.500	1.000	
A4	4.500	4.625	
B1	.613	1.021	SEE DETAIL A
C1	.613	2.671	SEE DETAIL A
D1	.613	4.620	SEE DETAIL A
E1	1.655	5.013	SEE DETAIL A
H1	4.013	1.437	SEE DETAIL B
C1	4.013	3.251	SEE DETAIL A
H1	4.013	4.621	SEE DETAIL A

4

3

PROPRIETARY AND CONFIDENTIAL
 THIS DRAWING IS THE PROPERTY OF JPL/CALTECH AND IS NOT TO BE REPRODUCED OR TRANSMITTED IN ANY FORM OR BY ANY MEANS, ELECTRONIC OR MECHANICAL, WITHOUT PERMISSION IN WRITING FROM JPL/CALTECH.

ITEM	PART NO.	DESCRIPTION	MATERIAL	SPECIFICATION	WT.
	-12	PLATE			
APPROVALS		DATE			
DR.	CAB	022409	ELECTRONIC ENCLOSURE, TOP PLATE MTP-H		
ENR.	JQX	031307	JPL/CALTECH CENTER FOR OPTO-ELECTRONIC RESEARCH 1050 TULLY HESBURN BLVD BOULDER, CO 80506		
CHK.			SCALE 1:1		
APPD.			CASE CODE 0SEF6	DWG NO. 67708MTP-12	REV. A
EFFECTIVE			SHEET 1 of 1		

2

1

HALO MTP Design Package
 JPL/Caltech PROPRIETARY —Not for Public Release or Redistribution

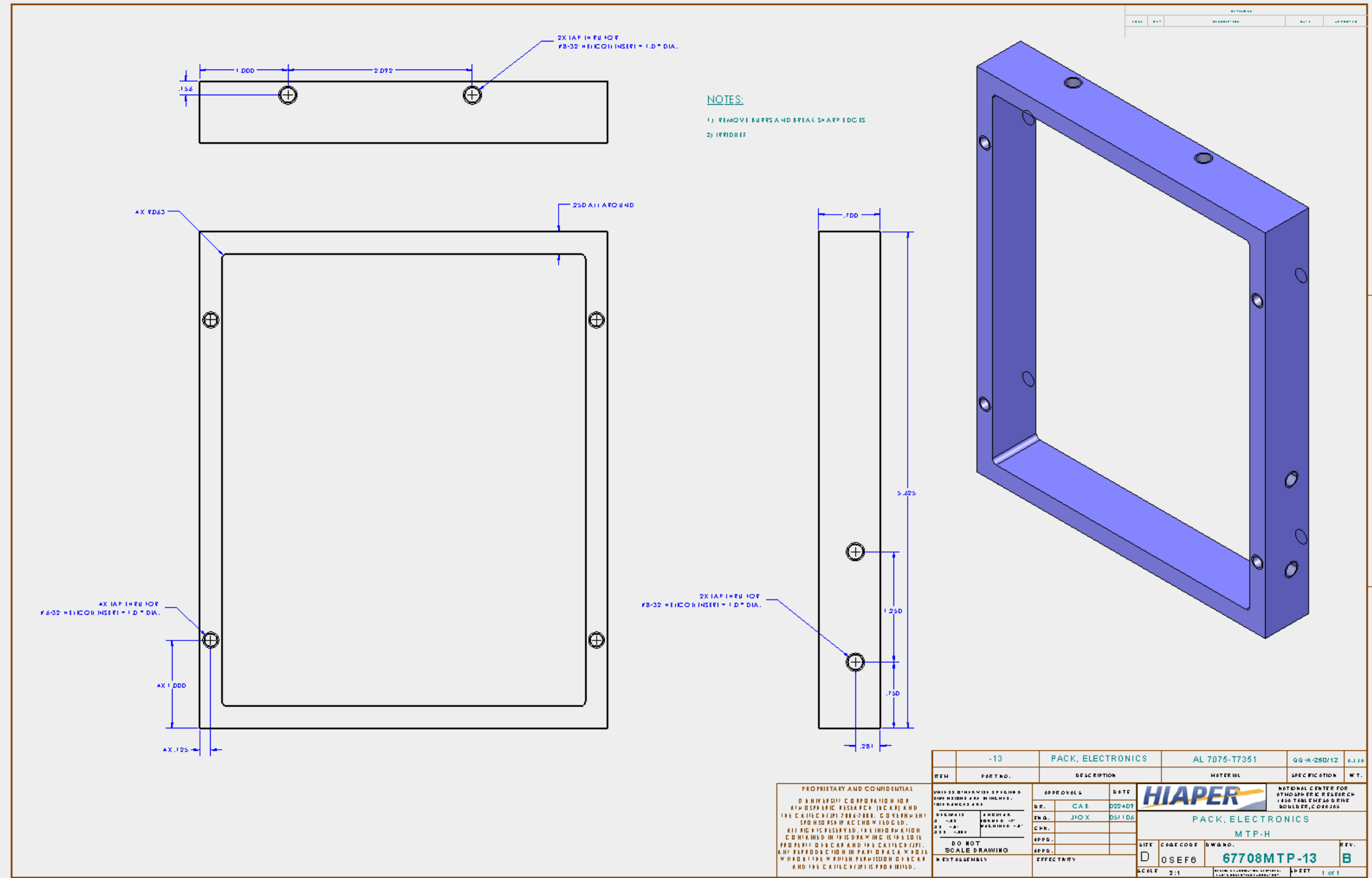

-13		PACK, ELECTRONICS	AL 7075-T7351	QQ-A-250/12	6.1.19
REV	PART NO.	DESCRIPTION	MATERIAL	SPECIFICATION	W.T.
PROPRIETARY AND CONFIDENTIAL DRAWING IS THE PROPERTY OF CALTECH AND JPL. IT IS TO BE USED ONLY FOR THE PURPOSES SPECIFIED HEREIN. NO PART OF THIS DRAWING IS TO BE REPRODUCED OR TRANSMITTED IN ANY FORM OR BY ANY MEANS, ELECTRONIC OR MECHANICAL, INCLUDING PHOTOCOPYING, RECORDING, OR BY ANY INFORMATION STORAGE AND RETRIEVAL SYSTEM, WITHOUT THE EXPRESS WRITTEN PERMISSION OF CALTECH AND JPL.		APPROVALS DR. CAE 022409 ENG. JHO X 051106 CDR.	DATE 022409 051106	NATIONAL CENTER FOR OPTOELECTRONIC RESEARCH 1550 TOWNSEND DRIVE SOLEDAD, CA 95068	
DO NOT SCALE DRAWING EXT ASSEMBLY		HIAPER PACK, ELECTRONICS MTP-H		REV. B	
SCALE 2:1		CASE CODE 0SEF8 DWG NO. 67708MTP-13		SHEET 1 OF 1	

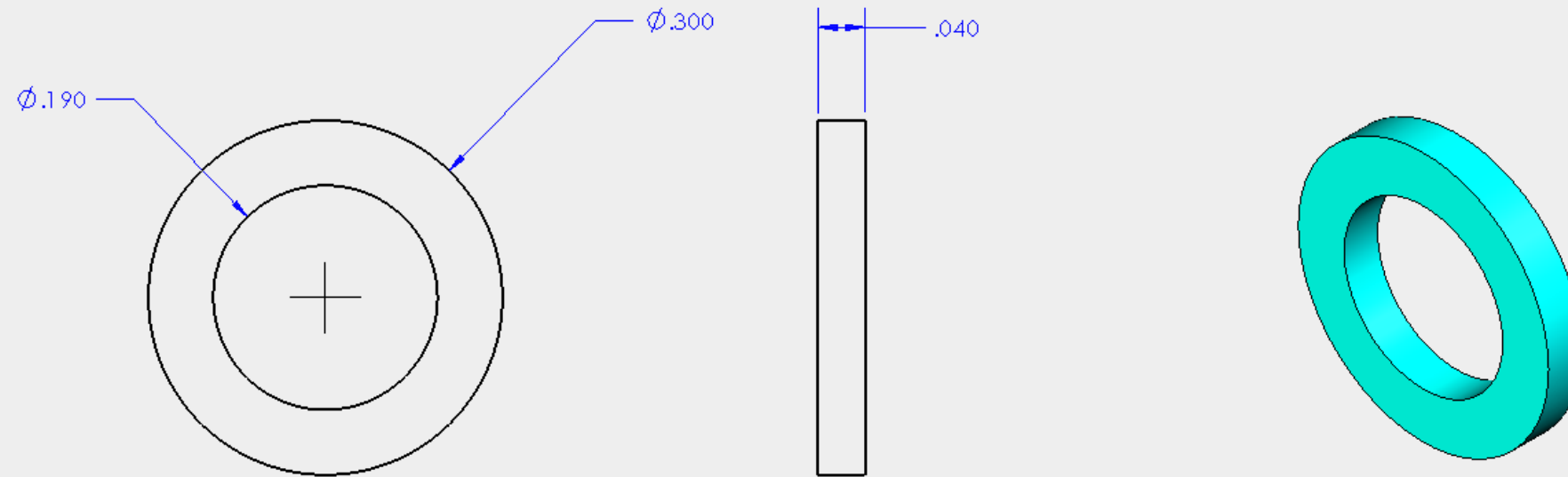

REVISIONS				
ZONE	REV	DESCRIPTION	DATE	APPROVED

NOTES:

??

	-14	SPACER, IDLER THICK			
ITEM	PART NO.	DESCRIPTION	MATERIAL	SPECIFICATION	WT.

PROPRIETARY AND CONFIDENTIAL
 © UNIVERSITY CORPORATION FOR ATMOSPHERIC RESEARCH (UCAR) AND THE CALTECH/JPL 2006-2008. GOVERNMENT SPONSORSHIP ACKNOWLEDGED. ALL RIGHTS RESERVED. THE INFORMATION CONTAINED IN THIS DRAWING IS THE SOLE PROPERTY OF UCAR AND THE CALTECH/JPL. ANY REPRODUCTION IN PART OR AS A WHOLE WITHOUT THE WRITTEN PERMISSION OF UCAR AND THE CALTECH/JPL IS PROHIBITED.

UNLESS OTHERWISE SPECIFIED DIMENSIONS ARE IN INCHES. TOLERANCES ARE:
 DECIMALS: X = ±.03, XX = ±.01, XXX = ±.004
 ANGULAR: FORMED = ±2°, MACHINED = ±.5°
 DO NOT SCALE DRAWING
 NEXT ASSEMBLY

APPROVALS		DATE
DR.	CAB	022409
ENG.	JFOX	010807
CHK.		
APPD.		
APPD.		
EFFECTIVITY		

		NATIONAL CENTER FOR ATMOSPHERIC RESEARCH 1850 TABLE MESA DRIVE BOULDER, CO 80305	
SPACER, IDLER THICK			
MTP-H			
SIZE	CAGE CODE	DWG NO.	REV.
B	0SEF6	67708MTP-14	NC
SCALE	8:1	DESIGN & FABRICATION SERVICES, EARTH OBSERVING LABORATORY	SHEET 1 of 1

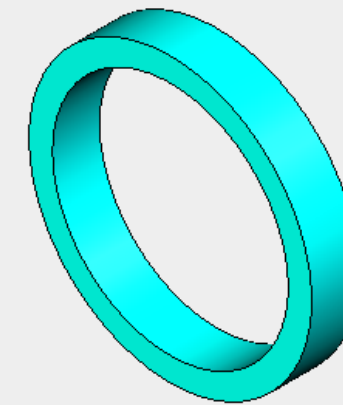
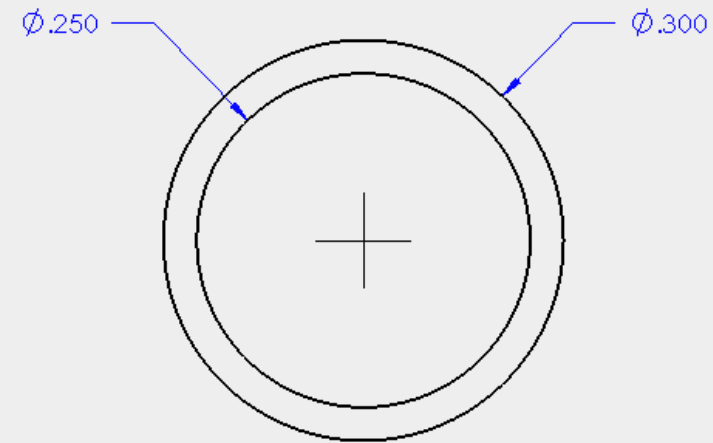

REVISIONS				
ZONE	REV	DESCRIPTION	DATE	APPROVED

NOTES:

??

X	-15	SPACER, IDLER THIN					
ITEM	PART NO.	DESCRIPTION	MATERIAL	SPECIFICATION	WT.		
<p>PROPRIETARY AND CONFIDENTIAL</p> <p>© UNIVERSITY CORPORATION FOR ATMOSPHERIC RESEARCH (UCAR) AND THE CALTECH/JPL 2006-2008. GOVERNMENT SPONSORSHIP ACKNOWLEDGED. ALL RIGHTS RESERVED. THE INFORMATION CONTAINED IN THIS DRAWING IS THE SOLE PROPERTY OF UCAR AND THE CALTECH/JPL. ANY REPRODUCTION IN PART OR AS A WHOLE WITHOUT THE WRITTEN PERMISSION OF UCAR AND THE CALTECH/JPL IS PROHIBITED.</p>		UNLESS OTHERWISE SPECIFIED DIMENSIONS ARE IN INCHES. TOLERANCES ARE:		<p>HIAPER</p> <p>NATIONAL CENTER FOR ATMOSPHERIC RESEARCH 1850 TABLE MESA DRIVE BOULDER, CO 80305</p>			
		DECIMALS: X = ±.03 XX = ±.01 XXX = ±.004		ANGULAR: FORMED = ±2° MACHINED = ±.5°		APPROVALS DR. CAB 022409 ENG. JFOX 010807 CHK. APPD.	
		DO NOT SCALE DRAWING NEXT ASSEMBLY		EFFECTIVITY		SPACER, IDLER THIN MTP-H	
		SIZE	CAGE CODE	DWG NO.	REV.		
B	0SEF6	67708MTP-15	NC				
SCALE	8:1	DESIGN & FABRICATION SERVICES, EARTH OBSERVING LABORATORY	SHEET	1 of 1			

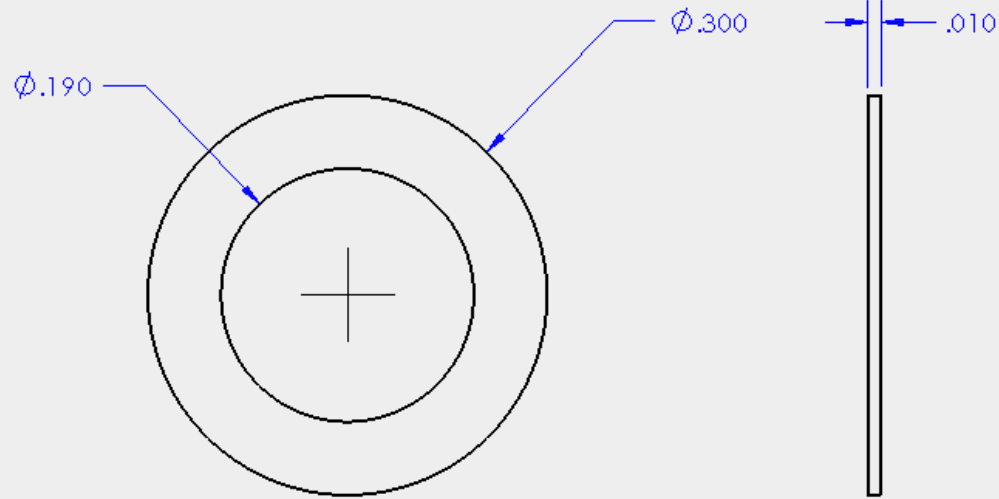

REVISIONS				
ZONE	REV	DESCRIPTION	DATE	APPROVED

NOTES:

??

	-16	SPACER, IDLER THIN SMALL HOLE				
ITEM	PART NO.	DESCRIPTION	MATERIAL	SPECIFICATION	WT.	
<p>PROPRIETARY AND CONFIDENTIAL</p> <p>© UNIVERSITY CORPORATION FOR ATMOSPHERIC RESEARCH (UCAR) AND THE CALTECH/JPL 2006-2008. GOVERNMENT SPONSORSHIP ACKNOWLEDGED. ALL RIGHTS RESERVED. THE INFORMATION CONTAINED IN THIS DRAWING IS THE SOLE PROPERTY OF UCAR AND THE CALTECH/JPL. ANY REPRODUCTION IN PART OR AS A WHOLE WITHOUT THE WRITTEN PERMISSION OF UCAR AND THE CALTECH/JPL IS PROHIBITED.</p>	UNLESS OTHERWISE SPECIFIED DIMENSIONS ARE IN INCHES. TOLERANCES ARE: DECIMALS: X = ±.03, XX = ±.01, XXX = ±.004 ANGULAR: FORMED = ±2°, MACHINED = ±.5°		APPROVALS DR. CAB 022409 ENG. JFOX 010807 CHK. APPD. APPD. EFFECTIVITY	DATE 022409 010807	 NATIONAL CENTER FOR ATMOSPHERIC RESEARCH 1850 TABLE MESA DRIVE BOULDER, CO 80305	
	DO NOT SCALE DRAWING		SPACER, IDLER THIN SMALL HOLE MTP-H			
	NEXT ASSEMBLY	SIZE B	CAGE CODE 0SEF6	DWG NO. 67708MTP-16	REV. NC	
		SCALE 8:1	DESIGN & FABRICATION SERVICES, EARTH OBSERVING LABORATORY		SHEET 1 of 1	

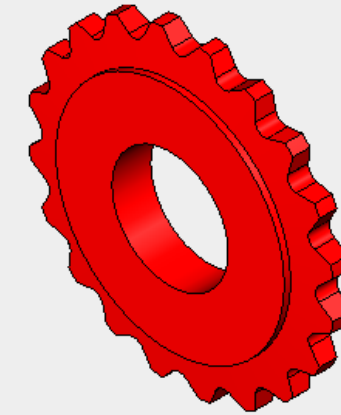
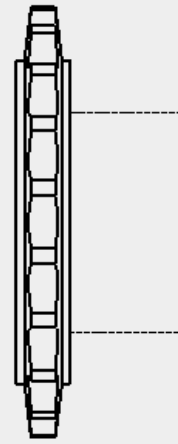
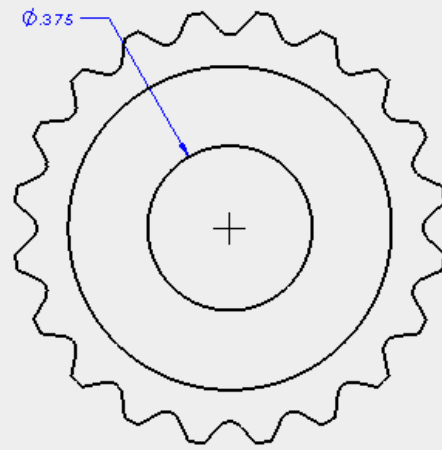

NOTE:

PRECISION INDUSTRIAL COMPONENTS CORPORATION (PIC-DESIGN) PART NUMBER EM5-20 MODIFIED AS SHOWN.

ITEM	PART NO.	DESCRIPTION	MATERIAL	SPECIFICATION	WT.
	-17	SPROCKET, MODIFIED EM5-20 IDLER			

PROPRIETARY AND CONFIDENTIAL © UNIVERSITY CORPORATION FOR ATMOSPHERIC RESEARCH (UCAR) AND THE CALTECH/JPL 2006-2008. GOVERNMENT SPONSORSHIP ACKNOWLEDGED. ALL RIGHTS RESERVED. THE INFORMATION CONTAINED IN THIS DRAWING IS THE SOLE PROPERTY OF UCAR AND THE CALTECH/JPL. ANY REPRODUCTION IN PART OR AS A WHOLE WITHOUT THE WRITTEN PERMISSION OF UCAR AND THE CALTECH/JPL IS PROHIBITED.	UNLESS OTHERWISE SPECIFIED DIMENSIONS ARE IN INCHES. TOLERANCES ARE: DECIMALS: X = ±.03 XX = ±.01 XXX = ±.005 ANGULAR: FORMED ±2° MACHINED ±.5° DO NOT SCALE DRAWING NEXT ASSEMBLY	APPROVALS DR. CAB 022409 ENG. JFOX 111006 CHK. APPD. APPD.	DATE 022409 111006	NATIONAL CENTER FOR ATMOSPHERIC RESEARCH 1850 TABLE MESA DRIVE BOULDER, CO 80305	
	SPROCKET, MODIFIED EM5-20 IDLER MTP-H		SIZE C CAGE CODE 0SEF6 SCALE 4:1		DWG NO. 67708MTP-17 SHEET 1 of 1
	EFFECTIVITY		REV. B		PART NUMBER: 67708MTP-17
	DO NOT SCALE DRAWING		DATE: 022409		DRAWN BY: JFOX
	NEXT ASSEMBLY		CHECKED BY:		APPROVED BY:

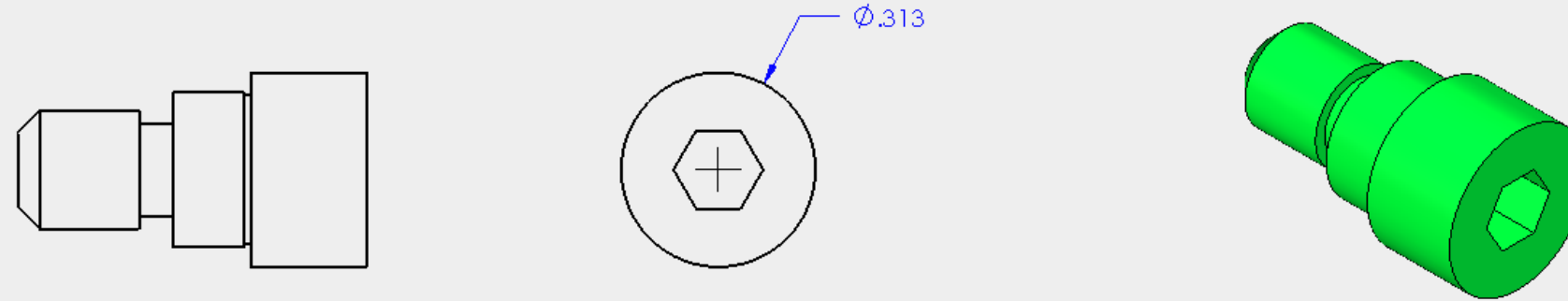

REVISIONS				
ZONE	REV	DESCRIPTION	DATE	APPROVED

NOTE:

PRECISION INDUSTRIAL COMPONENTS CORPORATION
 (PIC-DESIGN) PART NUMBER 4426 MODIFIED AS SHOWN

X	-18	SCREW, MODIFIED .25 x .125 SHOULDER	303 STAINLESS STEEL		
ITEM	PART NO.	DESCRIPTION	MATERIAL	SPECIFICATION	WT.

PROPRIETARY AND CONFIDENTIAL
 © UNIVERSITY CORPORATION FOR
 ATMOSPHERIC RESEARCH (UCAR) AND
 THE CALTECH/JPL 2006-2008. GOVERNMENT
 SPONSORSHIP ACKNOWLEDGED.
 ALL RIGHTS RESERVED. THE INFORMATION
 CONTAINED IN THIS DRAWING IS THE SOLE
 PROPERTY OF UCAR AND THE CALTECH/JPL.
 ANY REPRODUCTION IN PART OR AS A WHOLE
 WITHOUT THE WRITTEN PERMISSION OF UCAR
 AND THE CALTECH/JPL IS PROHIBITED.

UNLESS OTHERWISE SPECIFIED
 DIMENSIONS ARE IN INCHES.
 TOLERANCES ARE:
 DECIMALS: .X = ±.03
 .XX = ±.01
 .XXX = ±.004
 ANGULAR: FORMED = ±2°
 MACHINED = ±.5°
 DO NOT
 SCALE DRAWING
 NEXT ASSEMBLY

APPROVALS		DATE
DR.	CAB	022409
ENG.	JFOX	120406
CHK.		
APPD.		
APPD.		
EFFECTIVITY		

HIAPER		NATIONAL CENTER FOR ATMOSPHERIC RESEARCH 1850 TABLE MESA DRIVE BOULDER, CO 80305	
SCREW, MODIFIED .25 x .125 SHOULDER MTP-H			
SIZE	CAGE CODE	DWG NO.	REV.
B	0SEF6	67708MTP-18	NC
SCALE	DESIGN & FABRICATION SERVICES, EARTH OBSERVING LABORATORY		SHEET 1 of 1
4:1			

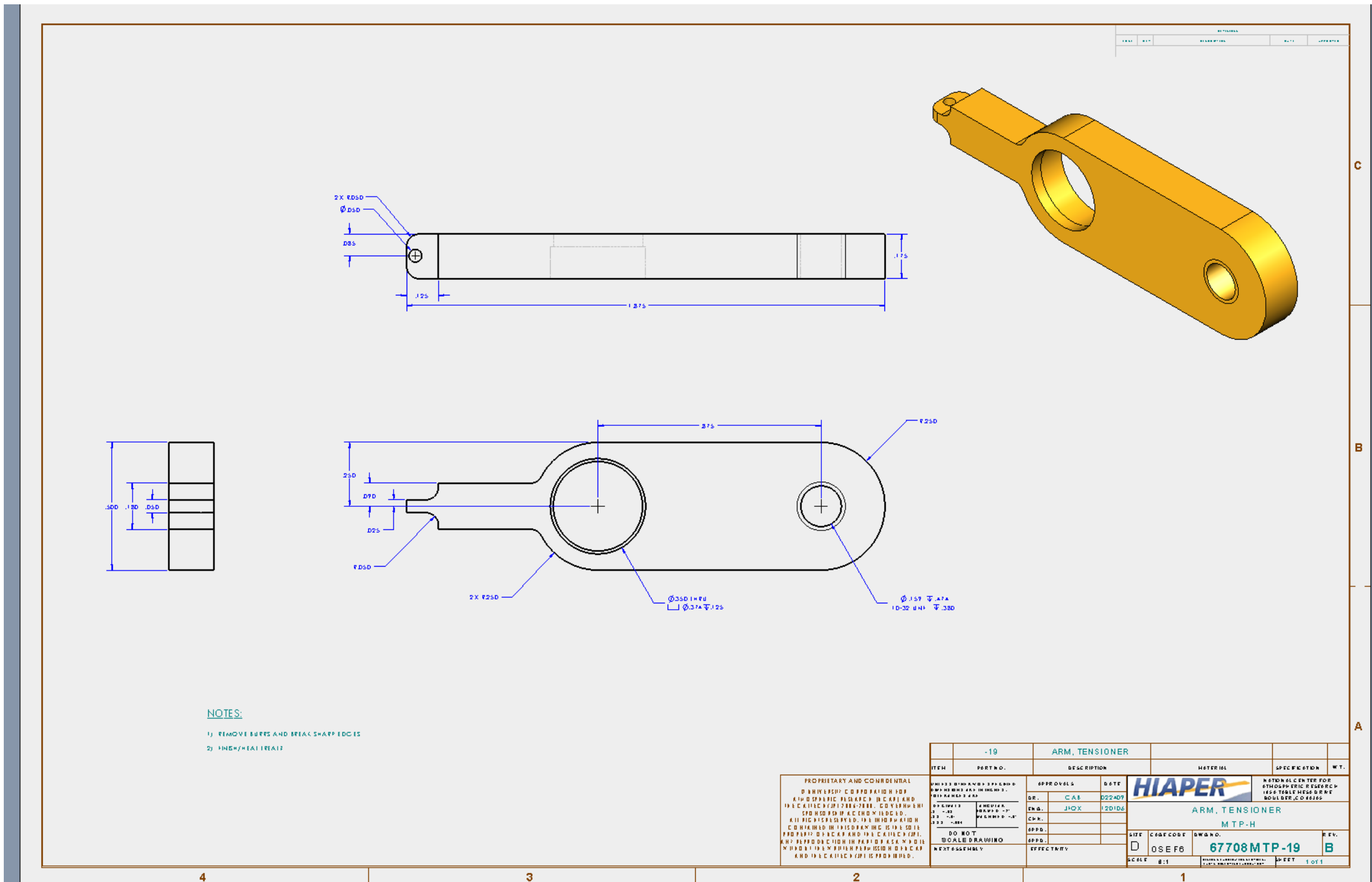

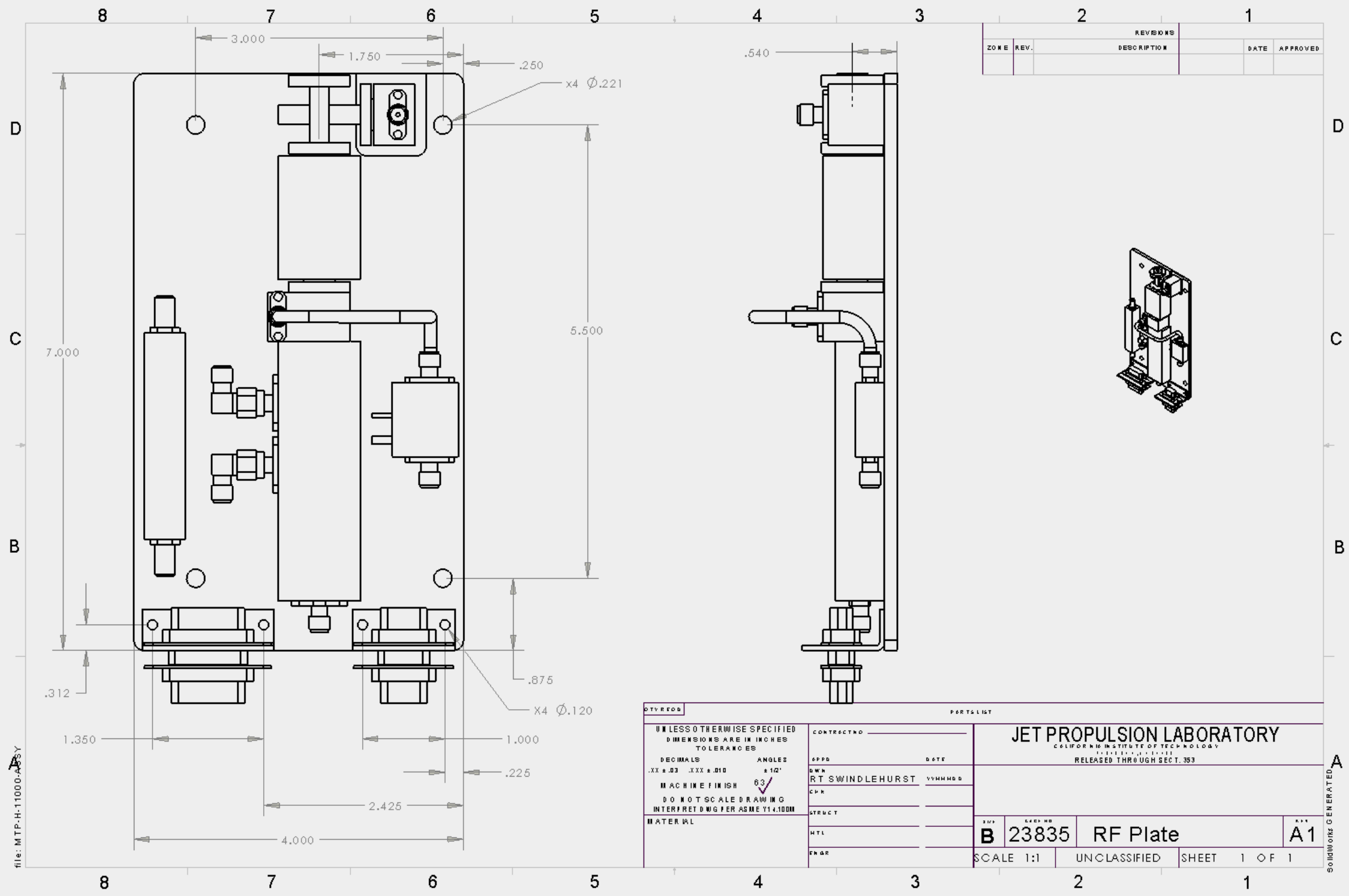

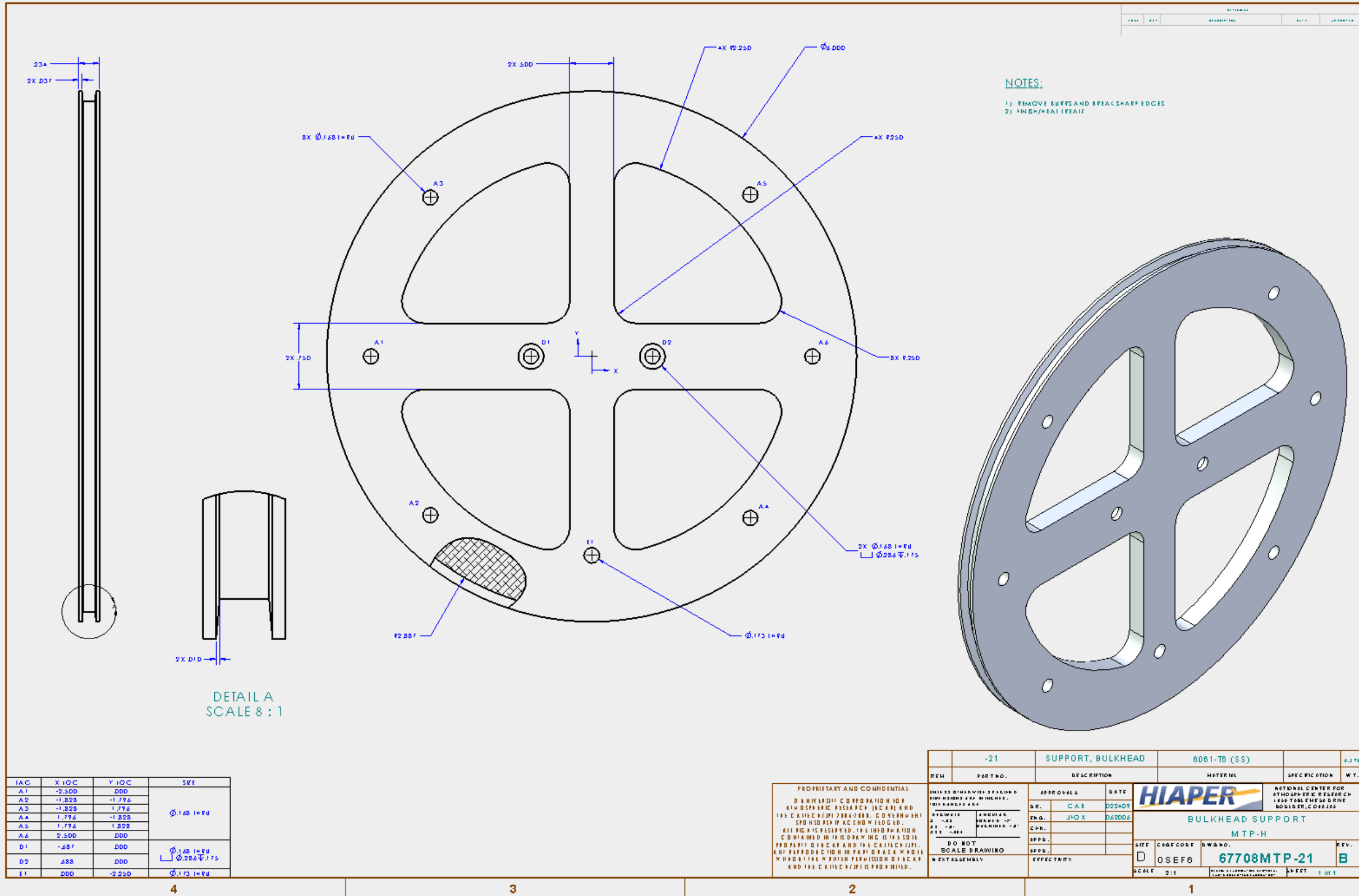

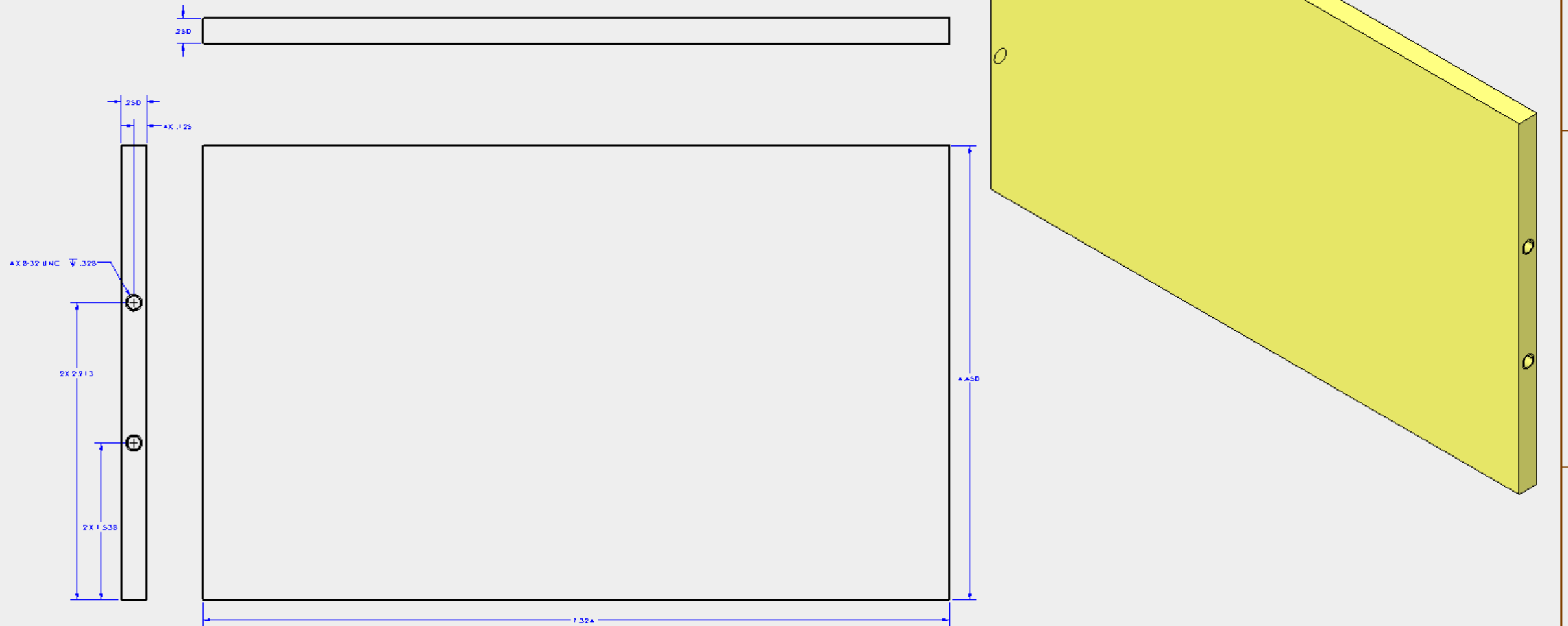

NOTES:

- 1) REMOVE BURRS AND BREAK SHARP EDGES
- 2) FINISH/HEAT TREAT



PROPRIETARY AND CONFIDENTIAL
 THIS DRAWING IS THE PROPERTY OF CALTECH AND JPL. IT IS TO BE USED ONLY FOR THE PURPOSES SPECIFIED IN THE DRAWING. IT IS NOT TO BE REPRODUCED, COPIED, OR TRANSMITTED IN ANY FORM OR BY ANY MEANS, ELECTRONIC OR MECHANICAL, INCLUDING PHOTOCOPYING, RECORDING, OR BY ANY INFORMATION STORAGE AND RETRIEVAL SYSTEM. ANY UNAUTHORIZED REPRODUCTION OR USE OF THIS DRAWING IS PROHIBITED. CALTECH AND JPL ACCEPT NO LIABILITY FOR ANY DAMAGES, INCLUDING CONSEQUENTIAL DAMAGES, ARISING FROM THE USE OF THIS DRAWING.

ITEM	PART NO.	DESCRIPTION	MATERIAL	SPECIFICATION	WT.
		PLATE, CONNECTING			
APPROVALS		DATE			
DR.	CAH	022409	NATIONAL CENTER FOR OPTO-ELECTRONIC RESEARCH 1850 TABLE MOUNTAIN BOULDER, CO 80508		
ENR.	JHX	111606	CONNECTING PLATE		
CHK.			MTP-H		
APPD.			SIT	CASE CODE	DWG NO.
EFFECTIVE			D	0SEF6	67708MTP-22
DO NOT SCALE DRAWING			SCALE	2:1	
NEXT ASSEMBLY					SHEET 1 of 1

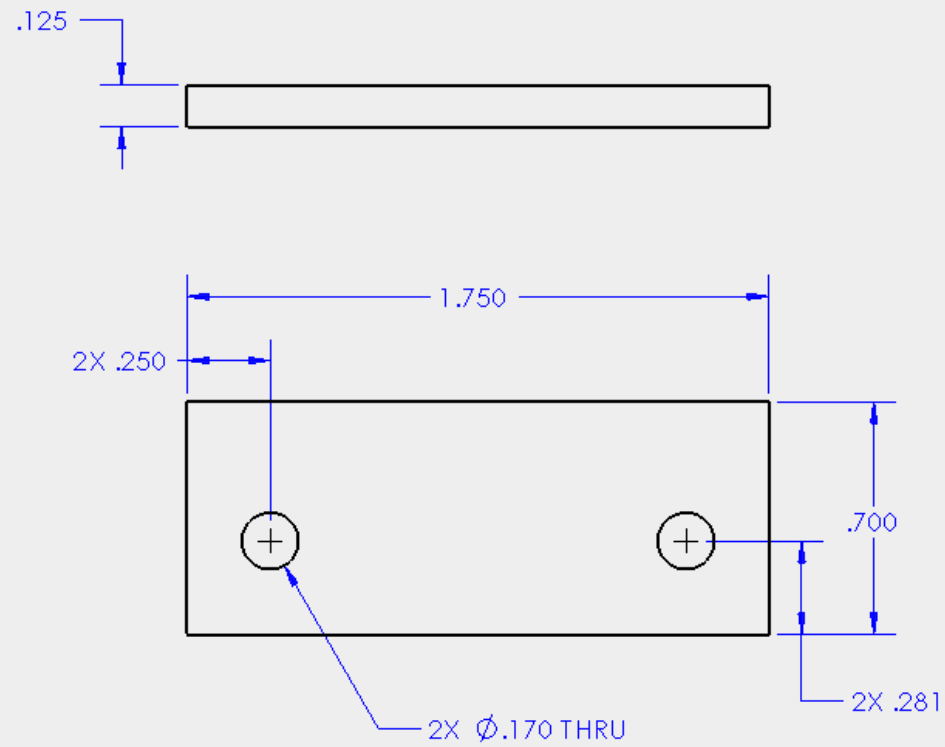

REVISIONS				
ZONE	REV	DESCRIPTION	DATE	APPROVED

NOTES:

- 1) REMOVE BURRS AND BREAK SHARP EDGES
- 2) FINISH/ HEAT TREAT?

	-23	INSULATOR, ELECTRONICS BOX			
ITEM	PART NO.	DESCRIPTION	MATERIAL	SPECIFICATION	WT.
<p>PROPRIETARY AND CONFIDENTIAL</p> <p>© UNIVERSITY CORPORATION FOR ATMOSPHERIC RESEARCH (UCAR) AND THE CALTECH/JPL 2006-2008. GOVERNMENT SPONSORSHIP ACKNOWLEDGED. ALL RIGHTS RESERVED. THE INFORMATION CONTAINED IN THIS DRAWING IS THE SOLE PROPERTY OF UCAR AND THE CALTECH/JPL. ANY REPRODUCTION IN PART OR AS A WHOLE WITHOUT THE WRITTEN PERMISSION OF UCAR AND THE CALTECH/JPL IS PROHIBITED.</p>	UNLESS OTHERWISE SPECIFIED DIMENSIONS ARE IN INCHES. TOLERANCES ARE: DECIMALS: X = ±.03, XX = ±.01, XXX = ±.004 ANGULAR: FORMED = ±2°, MACHINED = ±.5°		APPROVALS DR. CAB 022409 ENG. JFOX 080307 CHK. APPD. APPD.		DATE 022409 080307
	DO NOT SCALE DRAWING		EFFECTIVITY		NATIONAL CENTER FOR ATMOSPHERIC RESEARCH 1850 TABLE MESA DRIVE BOULDER, CO 80305
	NEXT ASSEMBLY		HIAPER ELECTRONICS BOX INSULATOR MTP-H		SIZE B CAGE CODE 0SEF6 DWG NO. 67708MTP-23 SCALE 2:1
					REV. NC DESIGN & FABRICATION SERVICES, EARTH OBSERVING LABORATORY SHEET 1 of 1

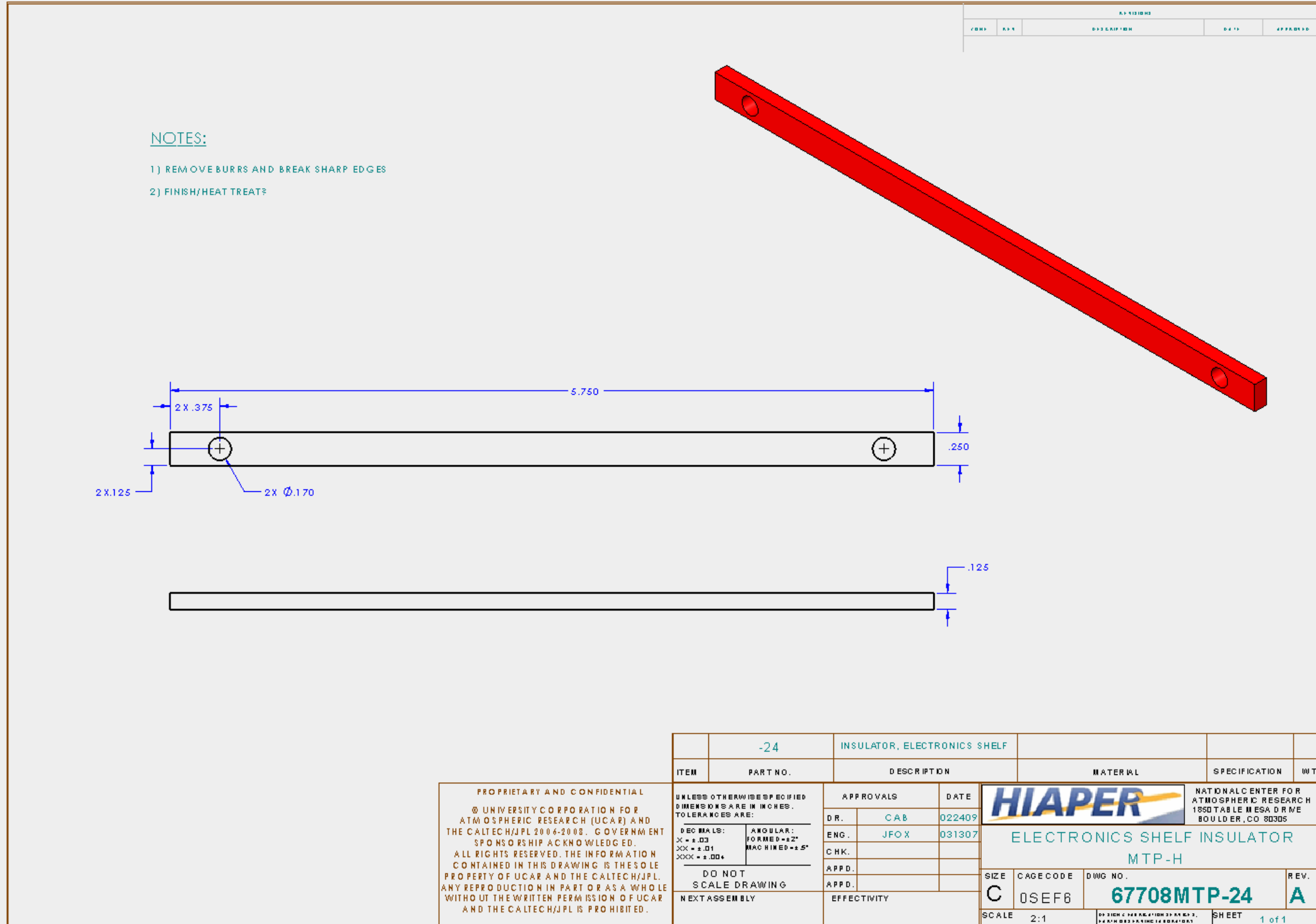

	REV	DATE	DESCRIPTION	BY	APP

15.875

ϕ .375

2X TAP FOR #8-32 HELICOIL INSERT = 1.0" DIA.

NOTES:

- 1) REMOVE BURRS AND BREAK SHARP EDGES
- 2) FINISH/HEAT TREAT

	-25	STANDOFF, FORWARD COMPARTMENT																							
ITEM	PART NO.	DESCRIPTION	MATERIAL	SPECIFICATION	WT.																				
<p>PROPRIETARY AND CONFIDENTIAL</p> <p>© UNIVERSITY CORPORATION FOR ATMOSPHERIC RESEARCH (UCAR) AND THE CALTECH/JPL 2006-2008. GOVERNMENT SPONSORSHIP ACKNOWLEDGED. ALL RIGHTS RESERVED. THE INFORMATION CONTAINED IN THIS DRAWING IS THE SOLE PROPERTY OF UCAR AND THE CALTECH/JPL. ANY REPRODUCTION IN PART OR AS A WHOLE WITHOUT THE WRITTEN PERMISSION OF UCAR AND THE CALTECH/JPL IS PROHIBITED.</p> <p>UNLESS OTHERWISE SPECIFIED DIMENSIONS ARE IN INCHES. TOLERANCES ARE:</p> <table style="font-size: small;"> <tr> <td>DECIMALS:</td> <td>ANGULAR:</td> </tr> <tr> <td>X = ±.03</td> <td>FORMED ±2°</td> </tr> <tr> <td>XX = ±.01</td> <td>MACHINED ±.5°</td> </tr> <tr> <td>XXX = ±.005</td> <td></td> </tr> </table> <p>DO NOT SCALE DRAWING</p> <p>NEXT ASSEMBLY</p>						DECIMALS:	ANGULAR:	X = ±.03	FORMED ±2°	XX = ±.01	MACHINED ±.5°	XXX = ±.005													
DECIMALS:	ANGULAR:																								
X = ±.03	FORMED ±2°																								
XX = ±.01	MACHINED ±.5°																								
XXX = ±.005																									
		<p>APPROVALS</p> <table style="font-size: small;"> <tr> <td>DR.</td> <td>CAB</td> <td>DATE</td> <td>022409</td> </tr> <tr> <td>ENG.</td> <td>JFOX</td> <td>DATE</td> <td>012907</td> </tr> <tr> <td>CHK.</td> <td></td> <td></td> <td></td> </tr> <tr> <td>APPD.</td> <td></td> <td></td> <td></td> </tr> <tr> <td>APPD.</td> <td></td> <td></td> <td></td> </tr> </table>	DR.	CAB	DATE	022409	ENG.	JFOX	DATE	012907	CHK.				APPD.				APPD.				<p>FORWARD COMPARTMENT STANDOFF</p> <p>MTP-H</p>		
DR.	CAB	DATE	022409																						
ENG.	JFOX	DATE	012907																						
CHK.																									
APPD.																									
APPD.																									
SIZE	CAGE CODE	DWG NO.	REV.																						
C	0SEF6	67708MTP-25	A																						
SCALE	1:1	DESIGN & FABRICATION BY PART NUMBER	SHEET	1 of 1																					

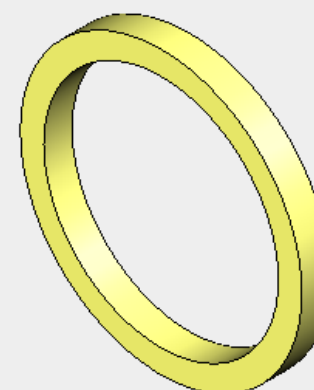
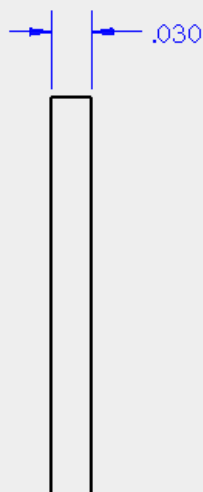
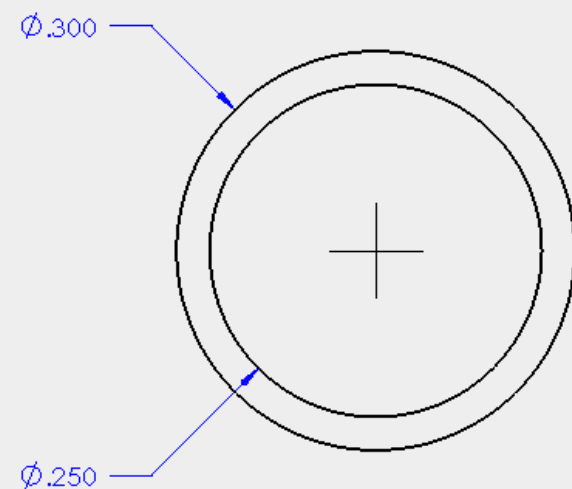

REVISIONS				
ZONE	REV	DESCRIPTION	DATE	APPROVED

NOTES:

??

	-26	SPACER, UPPER IDLER			
ITEM	PART NO.	DESCRIPTION	MATERIAL	SPECIFICATION	WT.

PROPRIETARY AND CONFIDENTIAL
 © UNIVERSITY CORPORATION FOR ATMOSPHERIC RESEARCH (UCAR) AND THE CALTECH/JPL 2006-2008. GOVERNMENT SPONSORSHIP ACKNOWLEDGED. ALL RIGHTS RESERVED. THE INFORMATION CONTAINED IN THIS DRAWING IS THE SOLE PROPERTY OF UCAR AND THE CALTECH/JPL. ANY REPRODUCTION IN PART OR AS A WHOLE WITHOUT THE WRITTEN PERMISSION OF UCAR AND THE CALTECH/JPL IS PROHIBITED.

UNLESS OTHERWISE SPECIFIED DIMENSIONS ARE IN INCHES. TOLERANCES ARE:
 DECIMALS: .X = ±.03
 .XX = ±.01
 .XXX = ±.004
 ANGULAR: FORMED = ±2°
 MACHINED = ±.5°
 DO NOT SCALE DRAWING
 NEXT ASSEMBLY

APPROVALS		DATE
DR.	CAB	022409
ENG.	JFOX	010807
CHK.		
APPD.		
APPD.		
EFFECTIVITY		

		NATIONAL CENTER FOR ATMOSPHERIC RESEARCH 1850 TABLE MESA DRIVE BOULDER, CO 80305	
IDLER SPACER, UPPER MTP-H			
SIZE	CAGE CODE	DWG NO.	REV.
B	0SEF6	67708MTP-26	NC
SCALE	8:1	DESIGN & FABRICATION SERVICES, EARTH OBSERVING LABORATORY	SHEET 1 of 1

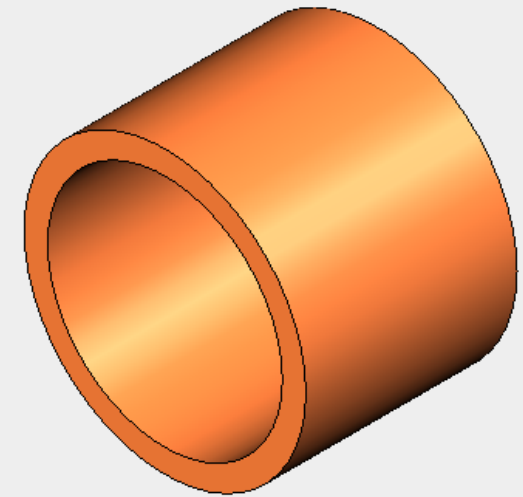
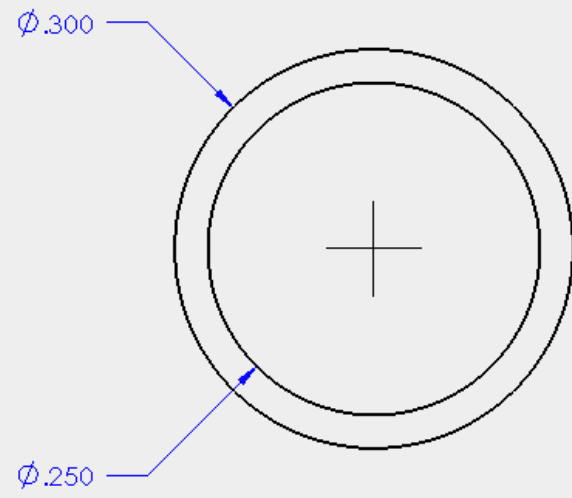

REVISIONS				
ZONE	REV	DESCRIPTION	DATE	APPROVED

NOTES:

??

	-27	SPACER, IDLER			
ITEM	PART NO.	DESCRIPTION	MATERIAL	SPECIFICATION	WT.

PROPRIETARY AND CONFIDENTIAL
 © UNIVERSITY CORPORATION FOR ATMOSPHERIC RESEARCH (UCAR) AND THE CALTECH/JPL 2006-2008. GOVERNMENT SPONSORSHIP ACKNOWLEDGED. ALL RIGHTS RESERVED. THE INFORMATION CONTAINED IN THIS DRAWING IS THE SOLE PROPERTY OF UCAR AND THE CALTECH/JPL. ANY REPRODUCTION IN PART OR AS A WHOLE WITHOUT THE WRITTEN PERMISSION OF UCAR AND THE CALTECH/JPL IS PROHIBITED.

UNLESS OTHERWISE SPECIFIED DIMENSIONS ARE IN INCHES. TOLERANCES ARE:
 DECIMALS: .X = ±.03
 .XX = ±.01
 .XXX = ±.004
 ANGULAR: FORMED = ±2°
 MACHINED = ±.5°
 DO NOT SCALE DRAWING
 NEXT ASSEMBLY

APPROVALS		DATE
DR.	CAB	022409
ENG.	JFOX	010807
CHK.		
APPD.		
APPD.		



NATIONAL CENTER FOR ATMOSPHERIC RESEARCH
 1850 TABLE MESA DRIVE
 BOULDER, CO 80305

IDLER, SPACER MTP-H			
SIZE	CAGE CODE	DWG NO.	REV.
B	0SEF6	67708MTP-27	NC
SCALE	8:1	DESIGN & FABRICATION SERVICES, EARTH OBSERVING LABORATORY	SHEET 1 of 1

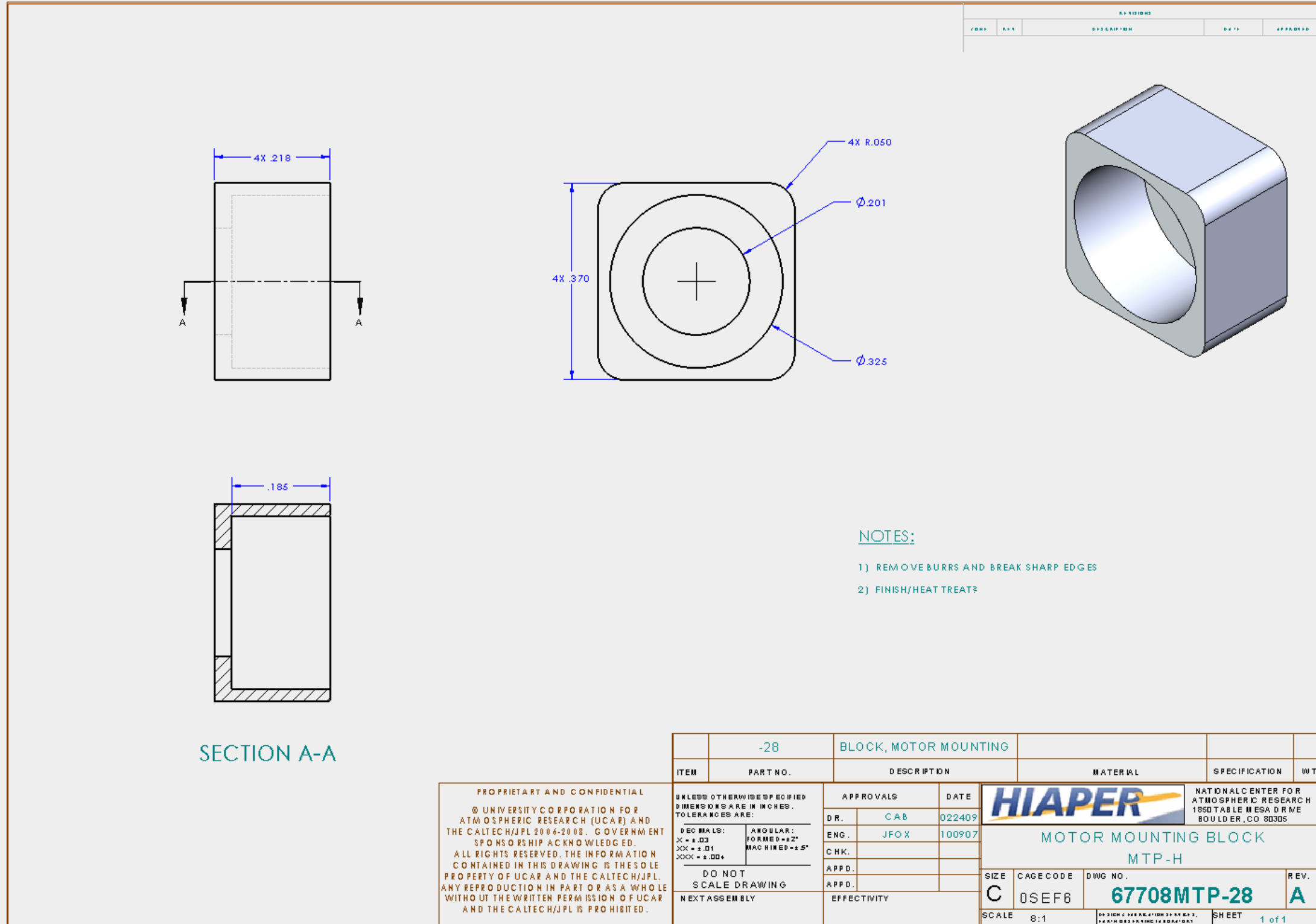

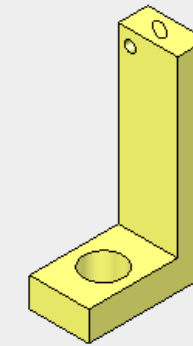
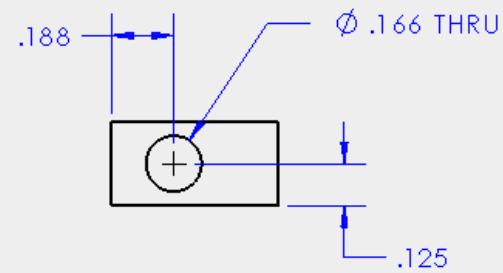
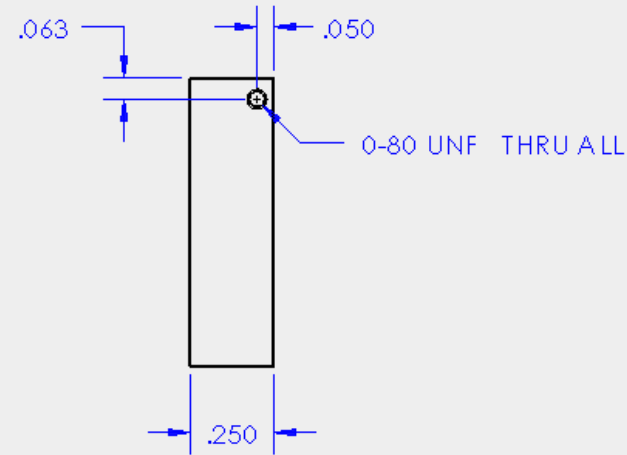
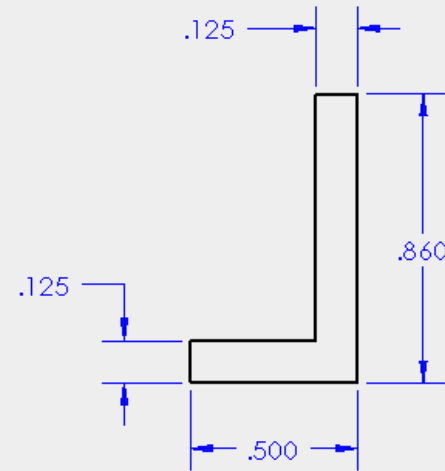



REVISIONS				
ZONE	REV	DESCRIPTION	DATE	APPROVED

NOTES:

- 1) REMOVE BURRS AND SHARP EDGES
- 2) FINISH/HEAT TREAT?

	-29	BRACKET, POSITION SENSOR																								
ITEM	PART NO.	DESCRIPTION	MATERIAL	SPECIFICATION	WT.																					
<p>PROPRIETARY AND CONFIDENTIAL</p> <p>© UNIVERSITY CORPORATION FOR ATMOSPHERIC RESEARCH (UCAR) AND THE CALTECH/JPL 2006-2008. GOVERNMENT SPONSORSHIP ACKNOWLEDGED. ALL RIGHTS RESERVED. THE INFORMATION CONTAINED IN THIS DRAWING IS THE SOLE PROPERTY OF UCAR AND THE CALTECH/JPL. ANY REPRODUCTION IN PART OR AS A WHOLE WITHOUT THE WRITTEN PERMISSION OF UCAR AND THE CALTECH/JPL IS PROHIBITED.</p>		<p>UNLESS OTHERWISE SPECIFIED DIMENSIONS ARE IN INCHES. TOLERANCES ARE:</p> <table border="1"> <tr> <td>DECIMALS: .X = ±.03 .XX = ±.01 .XXX = ±.004</td> <td>ANGULAR: FORMED=±2° MACHINED=±.5°</td> </tr> </table> <p>DO NOT SCALE DRAWING NEXT ASSEMBLY</p>	DECIMALS: .X = ±.03 .XX = ±.01 .XXX = ±.004	ANGULAR: FORMED=±2° MACHINED=±.5°	<table border="1"> <tr> <th colspan="2">APPROVALS</th> <th>DATE</th> </tr> <tr> <td>DR.</td> <td>CAB</td> <td>022409</td> </tr> <tr> <td>ENG.</td> <td>JFOX</td> <td>111006</td> </tr> <tr> <td>CHK.</td> <td></td> <td></td> </tr> <tr> <td>APPD.</td> <td></td> <td></td> </tr> <tr> <td>APPD.</td> <td></td> <td></td> </tr> </table>	APPROVALS		DATE	DR.	CAB	022409	ENG.	JFOX	111006	CHK.			APPD.			APPD.			 <p>NATIONAL CENTER FOR ATMOSPHERIC RESEARCH 1850 TABLE MESA DRIVE BOULDER, CO 80305</p>	<p>POSITION SENSOR BRACKET MTP-H</p>	
DECIMALS: .X = ±.03 .XX = ±.01 .XXX = ±.004	ANGULAR: FORMED=±2° MACHINED=±.5°																									
APPROVALS		DATE																								
DR.	CAB	022409																								
ENG.	JFOX	111006																								
CHK.																										
APPD.																										
APPD.																										
SIZE	CAGE CODE	DWG NO.	REV.																							
B	0SEF6	67708MTP-29	NC																							
SCALE	2:1	DESIGN & FABRICATION SERVICES, EARTH OBSERVING LABORATORY	SHEET	1 of 1																						

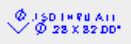
HALO MTP Design Package
 JPL/Caltech PROPRIETARY —Not for Public Release or Redistribution

IAC	X IOC	Y IOC	SIZE
A1	7.100	.650	
A2	7.100	2.250	
A3	3.900	.650	
A4	3.900	2.250	
A5	3.350	.650	
A6	3.350	2.250	
A7	.150	.650	
A8	.150	2.250	
B1	6.150	.250	
B2	6.150	2.250	
B3	1.100	.250	
B4	1.100	2.250	

NOTES:

- 1) REMOVE BURRS AND BREAK SHARP EDGES
- 2) HNER/REAL TREAT

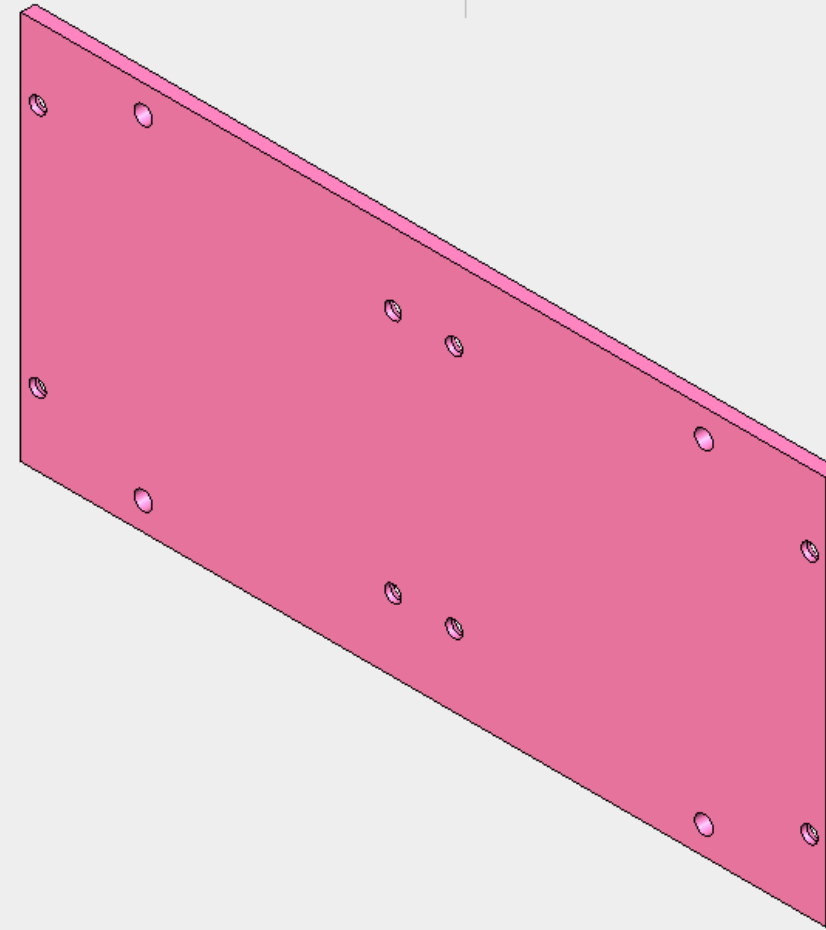
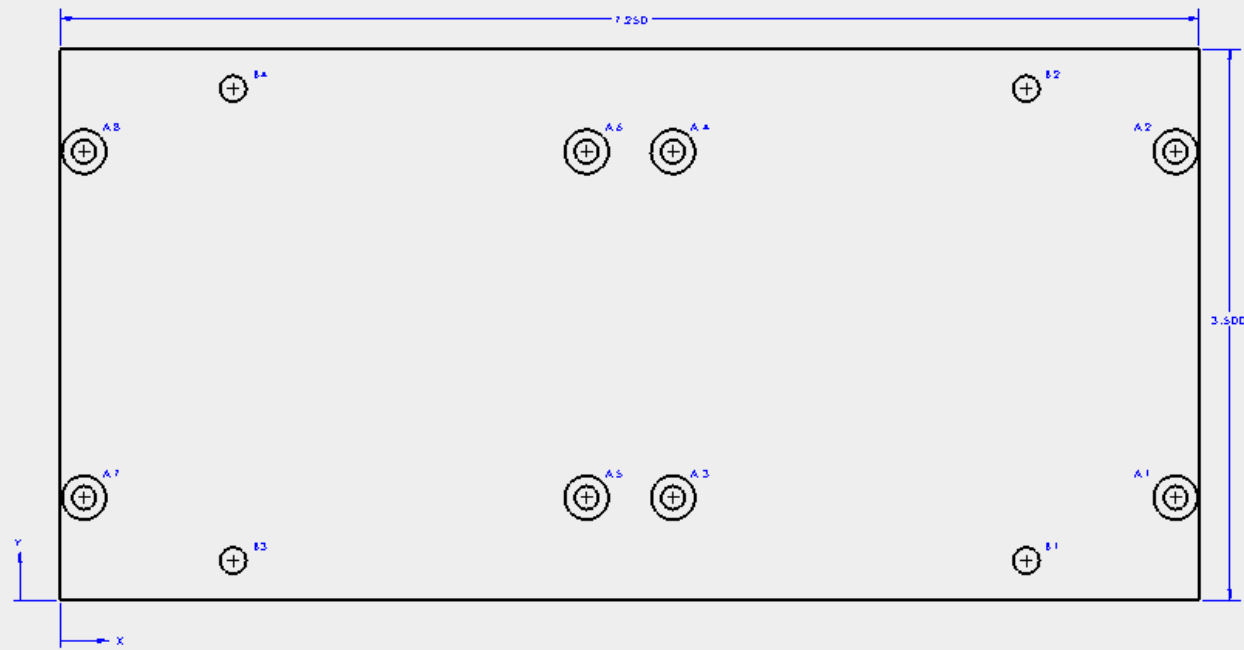

ITEM	PART NO.	DESCRIPTION	MATERIAL	SPECIFICATION	WT.
	-30	SUB-PLATE, POWER SUPPLY			
PROPRIETARY AND CONFIDENTIAL THIS DRAWING IS THE PROPERTY OF CALTECH AND JPL. IT IS TO BE USED ONLY FOR THE PURPOSES SPECIFIED HEREIN. NO PART OF THIS DRAWING IS TO BE REPRODUCED OR TRANSMITTED IN ANY FORM OR BY ANY MEANS, ELECTRONIC OR MECHANICAL, INCLUDING PHOTOCOPYING, RECORDING, OR BY ANY INFORMATION STORAGE AND RETRIEVAL SYSTEM, WITHOUT THE EXPRESS WRITTEN PERMISSION OF CALTECH AND JPL.		APPROVALS DR. CAE 022409 ENR. JHX 032901 CWR. APPD. EFFECTIVE	 POWER SUPPLY, SUBPLATE MTP-H	NATIONAL CENTER FOR OPTICALLY ASSISTED RESEARCH 1850 TABLE MOUNTAIN BOULDER, CO 80508	
DO NOT SCALE DRAWING NEXT ASSEMBLY	SHEET 1 OF 1 CASE CODE 0SEF6 DWG NO. 67708MTP-30	REV. A			

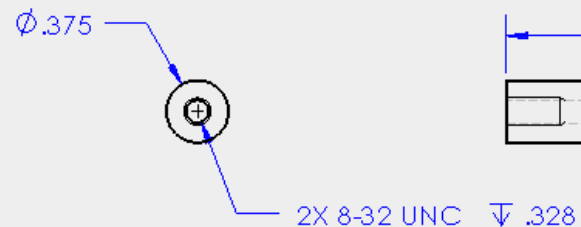

NOTES:

??

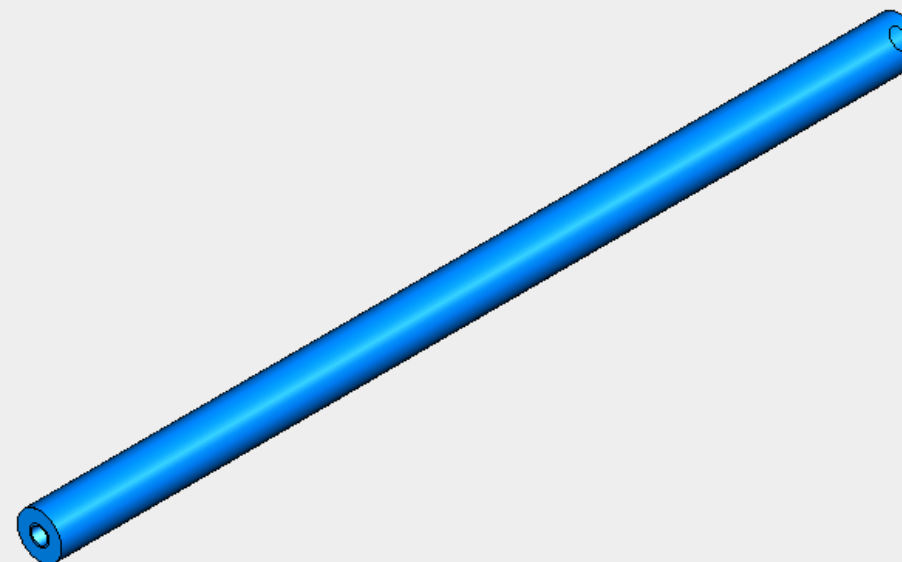

REVISIONS				
ZONE	REV	DESCRIPTION	DATE	APPROVED

	-31	ROD, REAR COMPARTMENT																																								
ITEM	PART NO.	DESCRIPTION	MATERIAL	SPECIFICATION	WT.																																					
<p>PROPRIETARY AND CONFIDENTIAL</p> <p>© UNIVERSITY CORPORATION FOR ATMOSPHERIC RESEARCH (UCAR) AND THE CALTECH/JPL 2006-2008. GOVERNMENT SPONSORSHIP ACKNOWLEDGED. ALL RIGHTS RESERVED. THE INFORMATION CONTAINED IN THIS DRAWING IS THE SOLE PROPERTY OF UCAR AND THE CALTECH/JPL. ANY REPRODUCTION IN PART OR AS A WHOLE WITHOUT THE WRITTEN PERMISSION OF UCAR AND THE CALTECH/JPL IS PROHIBITED.</p>		<p>UNLESS OTHERWISE SPECIFIED DIMENSIONS ARE IN INCHES. TOLERANCES ARE:</p> <table border="1"> <tr> <td>DECIMALS:</td> <td>ANGULAR:</td> </tr> <tr> <td>.X = ±.03</td> <td>FORMED = ±2°</td> </tr> <tr> <td>.XX = ±.01</td> <td>MACHINED = ±.5°</td> </tr> <tr> <td>.XXX = ±.004</td> <td></td> </tr> </table> <p>DO NOT SCALE DRAWING</p> <p>NEXT ASSEMBLY</p>	DECIMALS:	ANGULAR:	.X = ±.03	FORMED = ±2°	.XX = ±.01	MACHINED = ±.5°	.XXX = ±.004		<table border="1"> <tr> <th colspan="2">APPROVALS</th> <th>DATE</th> </tr> <tr> <td>DR.</td> <td>CAB</td> <td>022409</td> </tr> <tr> <td>ENG.</td> <td>JFOX</td> <td>011207</td> </tr> <tr> <td>CHK.</td> <td></td> <td></td> </tr> <tr> <td>APPD.</td> <td></td> <td></td> </tr> <tr> <td>APPD.</td> <td></td> <td></td> </tr> <tr> <td colspan="3">EFFECTIVITY</td> </tr> </table>	APPROVALS		DATE	DR.	CAB	022409	ENG.	JFOX	011207	CHK.			APPD.			APPD.			EFFECTIVITY			 <p>NATIONAL CENTER FOR ATMOSPHERIC RESEARCH 1850 TABLE MESA DRIVE BOULDER, CO 80305</p> <p>REAR COMPARTMENT ROD MTP-H</p>	<table border="1"> <tr> <td>SIZE</td> <td>CAGE CODE</td> <td>DWG NO.</td> <td>REV.</td> </tr> <tr> <td>B</td> <td>0SEF6</td> <td>67708MTP-31</td> <td>NC</td> </tr> </table>	SIZE	CAGE CODE	DWG NO.	REV.	B	0SEF6	67708MTP-31	NC
DECIMALS:	ANGULAR:																																									
.X = ±.03	FORMED = ±2°																																									
.XX = ±.01	MACHINED = ±.5°																																									
.XXX = ±.004																																										
APPROVALS		DATE																																								
DR.	CAB	022409																																								
ENG.	JFOX	011207																																								
CHK.																																										
APPD.																																										
APPD.																																										
EFFECTIVITY																																										
SIZE	CAGE CODE	DWG NO.	REV.																																							
B	0SEF6	67708MTP-31	NC																																							
		SCALE 1:1	DESIGN & FABRICATION SERVICES, EARTH OBSERVING LABORATORY	SHEET 1 of 1																																						

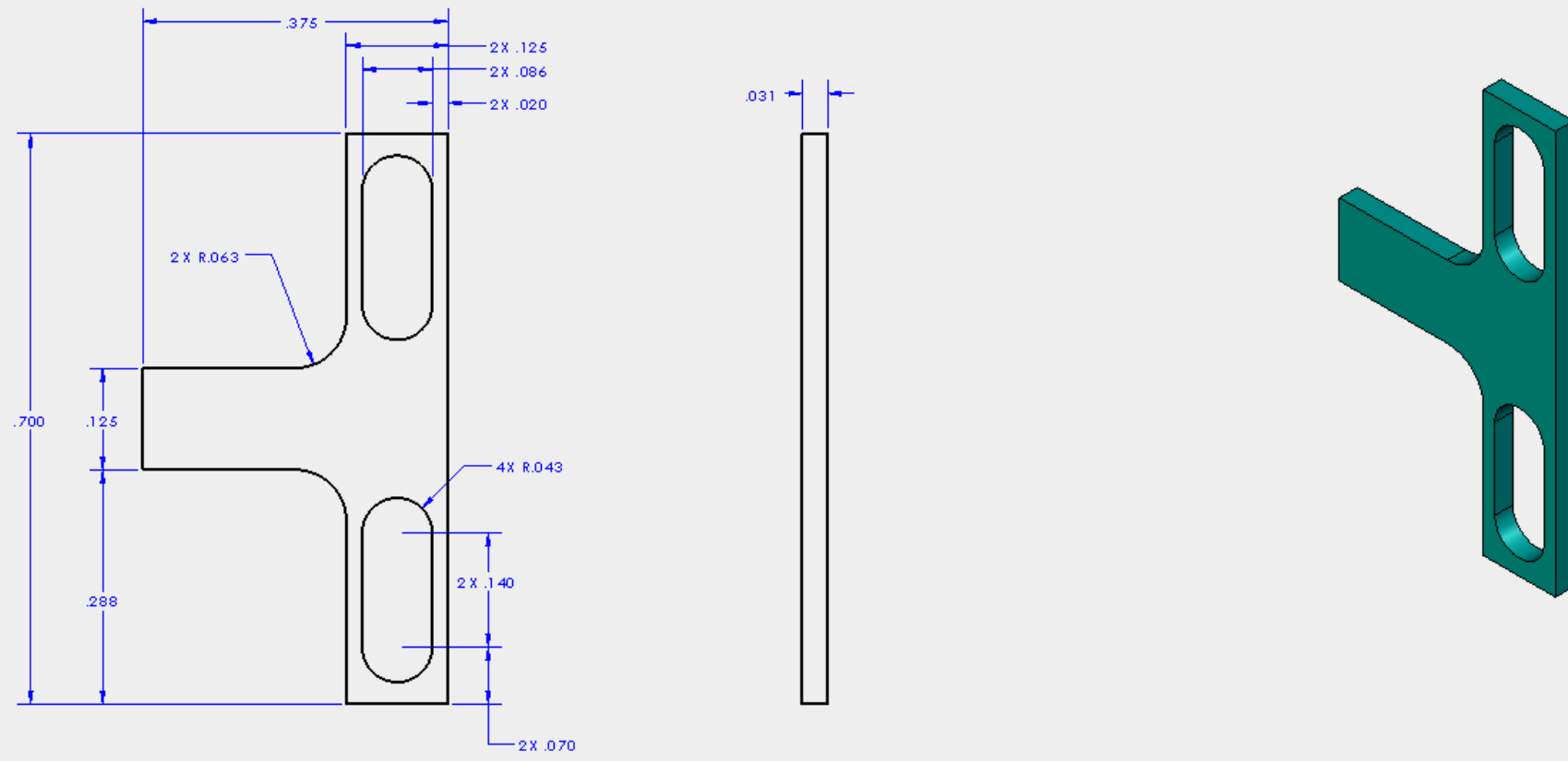

NOTES:

- 1) REMOVE BURRS AND SHARP EDGES
- 2) FINISH/HEAT TREAT?

PROPRIETARY AND CONFIDENTIAL
 © UNIVERSITY CORPORATION FOR
 ATMOSPHERIC RESEARCH (UCAR) AND
 THE CALTECH/JPL 2006-2008. GOVERNMENT
 SPONSORSHIP ACKNOWLEDGED.
 ALL RIGHTS RESERVED. THE INFORMATION
 CONTAINED IN THIS DRAWING IS THE SOLE
 PROPERTY OF UCAR AND THE CALTECH/JPL.
 ANY REPRODUCTION IN PART OR AS A WHOLE
 WITHOUT THE WRITTEN PERMISSION OF UCAR
 AND THE CALTECH/JPL IS PROHIBITED.

ITEM	PART NO.	DESCRIPTION	MATERIAL	SPECIFICATION	WT.
	-32	FLAG, SENSOR			

UNLESS OTHERWISE SPECIFIED DIMENSIONS ARE IN INCHES. TOLERANCES ARE:		APPROVALS	DATE	 NATIONAL CENTER FOR ATMOSPHERIC RESEARCH 1850 TABLE MESA DRIVE BOULDER, CO 80305
DECIMALS: X = ±.03 XX = ±.01 XXX = ±.004	ANGULAR: FORMED ±2° MACHINED ±.5°	DR. CAB	022409	
DO NOT SCALE DRAWING		ENG. JFOX	111006	
NEXT ASSEMBLY		CHK.		
		APPD.		

SIZE	CAGE CODE	DWG NO.	REV.
C	0SEF6	67708MTP-32	A
SCALE 8:1	BY JOHN C. PARSONS/JPL/JPL/UCAR FOR CALTECH/JPL/UCAR/UCAR		SHEET 1 of 1

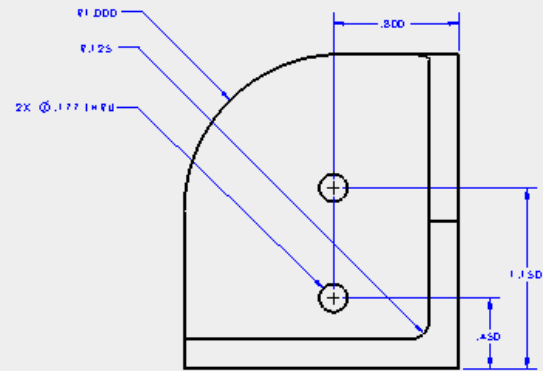
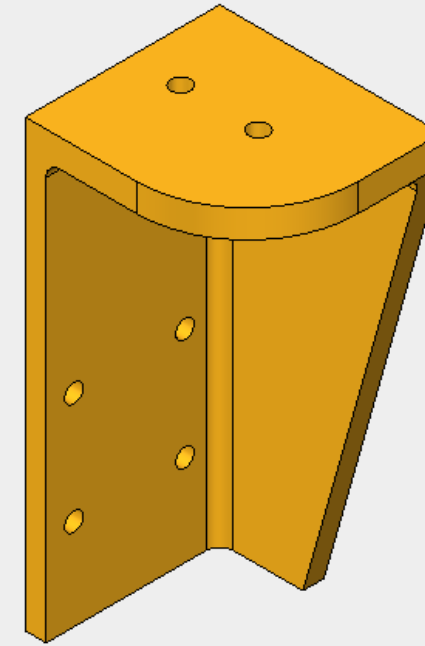
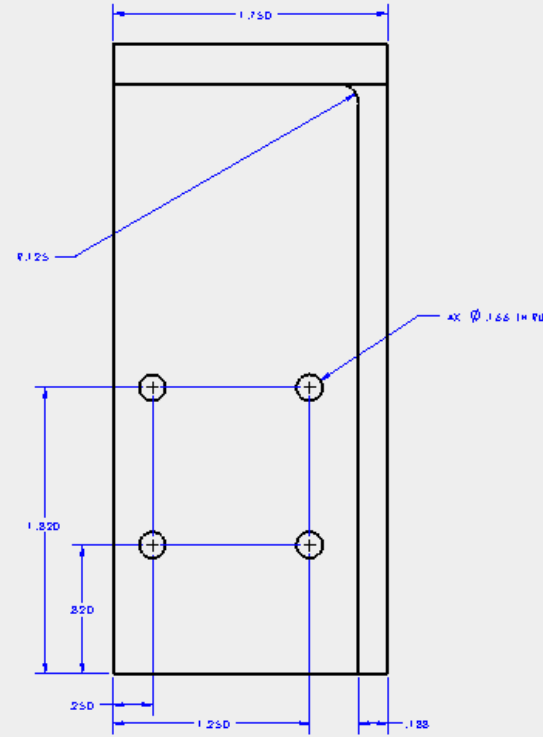
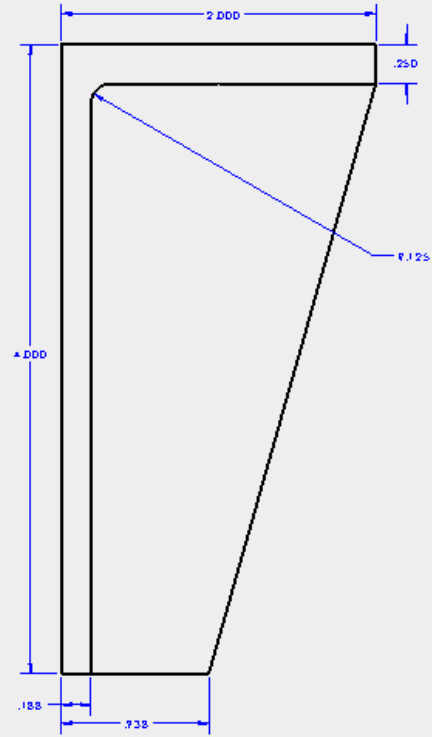

NOTES:

- 1) REMOVE BURRS AND BREAK SHARP EDGES
- 2) FINISH/HEAT TREAT

PROPRIETARY AND CONFIDENTIAL
 THIS DRAWING IS THE PROPERTY OF CALTECH AND JPL. IT IS TO BE USED ONLY FOR THE PURPOSES SPECIFIED IN THE DRAWING. NO PART OF THIS DRAWING IS TO BE REPRODUCED OR TRANSMITTED IN ANY FORM OR BY ANY MEANS, ELECTRONIC OR MECHANICAL, INCLUDING PHOTOCOPYING, RECORDING, OR BY ANY INFORMATION STORAGE AND RETRIEVAL SYSTEM. ANY REPRODUCTION OR TRANSMISSION OF THIS DRAWING WITHOUT THE EXPRESS PERMISSION OF CALTECH AND JPL IS PROHIBITED.

ITEM	PART NO.	DESCRIPTION	MATERIAL	SPECIFICATION	WT.
	-33	BRACKET, SINGLE SOURCE			
APPROVALS		DATE			
DR.	CAN	022407	JPL/Caltech Center for High Energy Laser Research 1850 TABLE MOUNTING BOULDER, CO 80506		
ENR.	JHX	110306	SOURCE BRACKET, SINGLE		
CHK.			MTP-H		
APPD.			SITF	CASE CODE	DWG NO.
EFFCTV			D	0SEF6	67708MTP-33
			SCALE	2:1	SHEET 1 of 1

4

3

2

1

HALO MTP Design Package
 JPL/Caltech PROPRIETARY —Not for Public Release or Redistribution

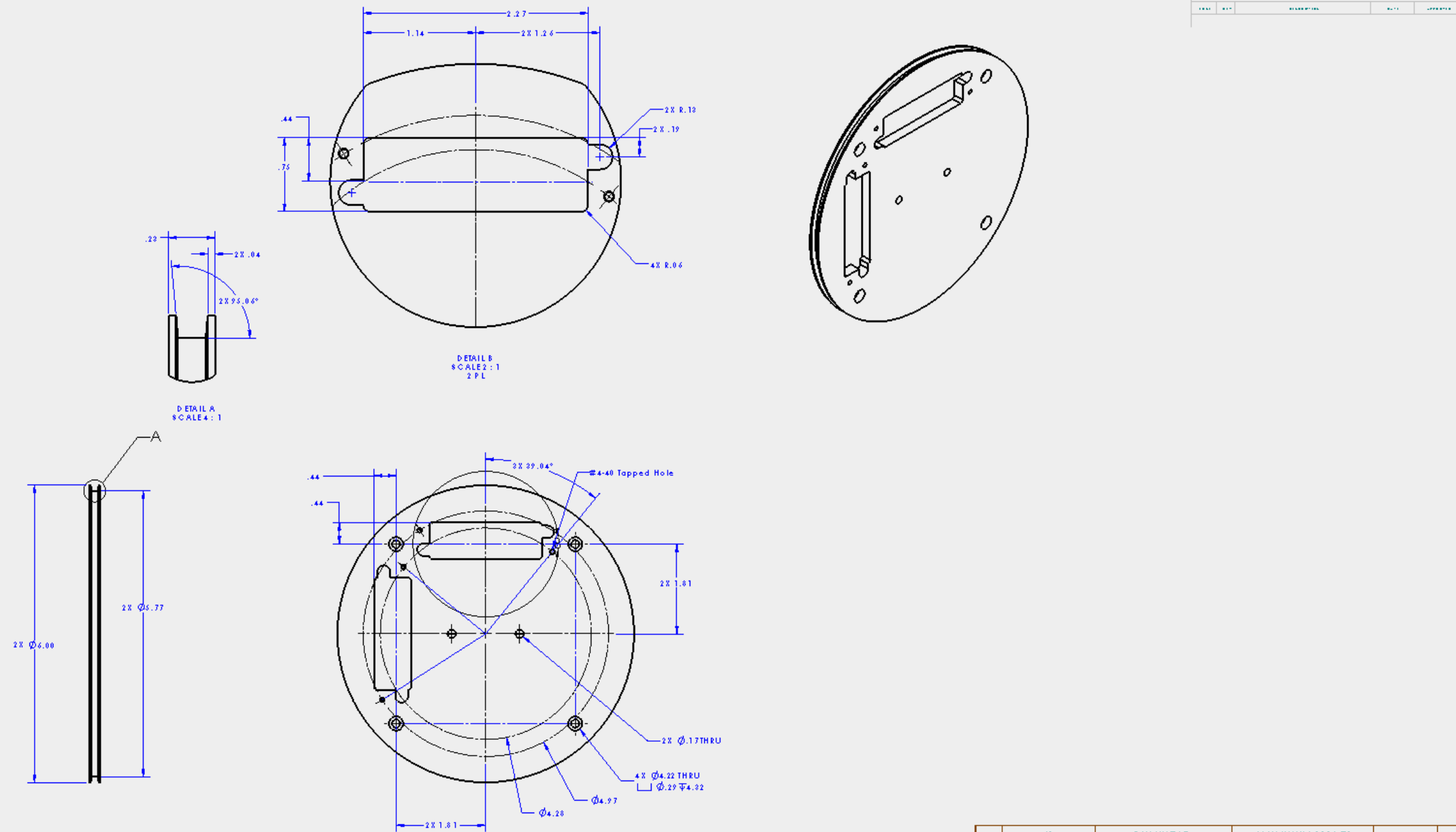

ITEM	PART NO.	DESCRIPTION	MATERIAL	SPECIFICATION	W.T.
	-40	BULKHEAD	ALUMINUM 6061-T6		

PROPRIETARY AND CONFIDENTIAL UNIVERSITY OF CALIFORNIA FOR ATMOSPHERIC RESEARCH IN CALIFORNIA 1963-1964 JPL/Caltech PROPRIETARY AND CONFIDENTIAL. ALL RIGHTS RESERVED. THIS DOCUMENT IS UNCLASSIFIED DATE 10/13/2010 BY 60322 UCRL 104601		APPROVALS DR. CAB 022409 ENR. JHOX 061106 CHK. APPD. EFFECTIVE	DATE 02/24/09 06/11/06	HIAPER PMS REAR BULKHEAD MTP-H	REVISION CENTER FOR ATMOSPHERIC RESEARCH 1525 TABLE MESA DRIVE BOULDER, CO 80506
DO NOT SCALE DRAWING NEXT ASSEMBLY	SIZE D CODE CODE 0SEF6 SCALE 1:2	DWG NO. 67708MTP-40 SHEET 1 OF 1	REV. B		

4 3 2 1

HALO MTP Design Package
 JPL/Caltech PROPRIETARY —Not for Public Release or Redistribution

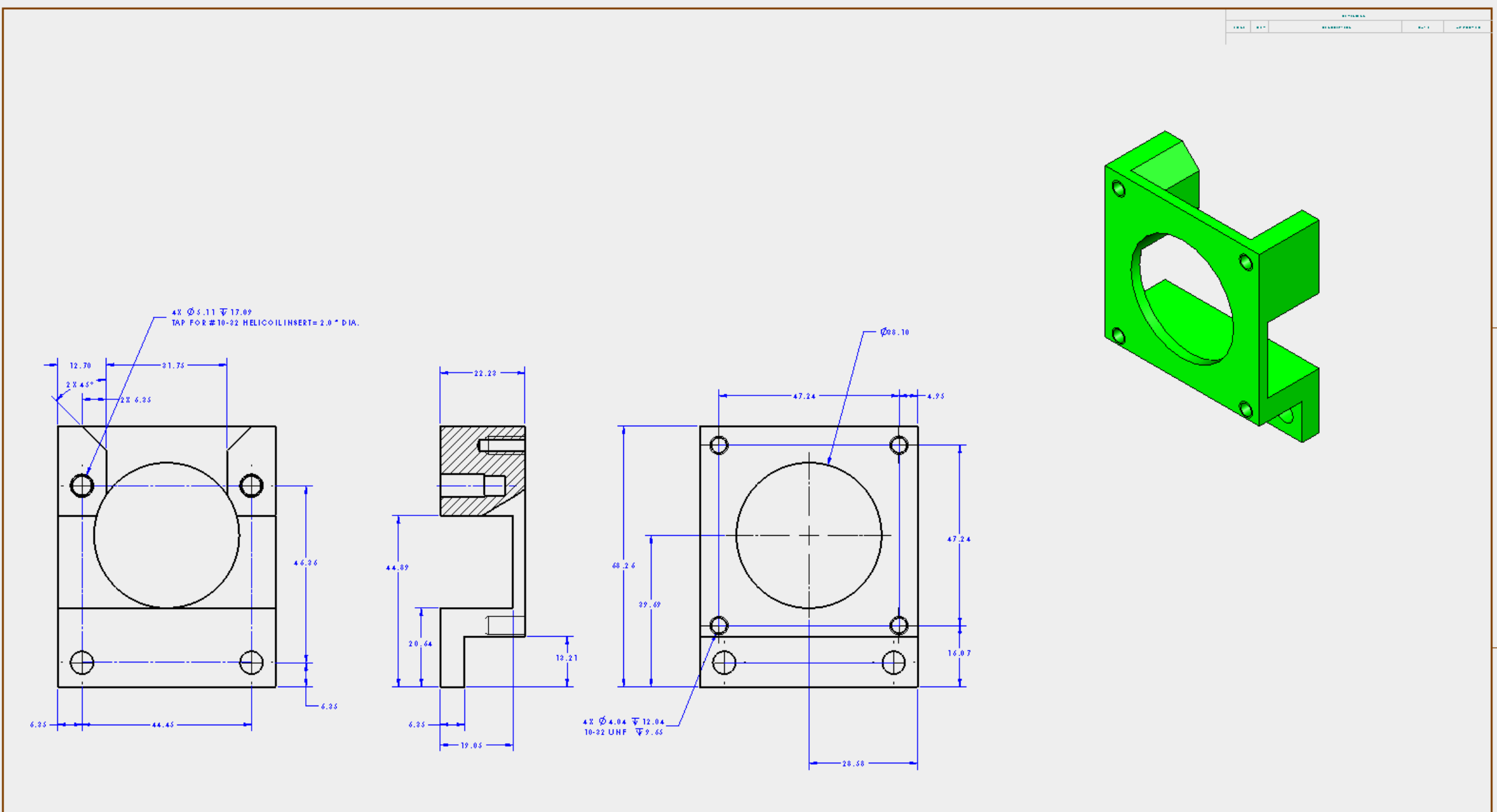

REV	PART NO.	DESCRIPTION	MATERIAL	SPECIFICATION	W.T.
	-41	BASE	ALUMINUM 6061-T6		
<p>PROPRIETARY AND CONFIDENTIAL THIS DRAWING IS THE PROPERTY OF CALTECH AND JPL. IT IS TO BE USED ONLY FOR THE PURPOSES SPECIFIED HEREIN. NO PART OF THIS DRAWING IS TO BE REPRODUCED OR TRANSMITTED IN ANY FORM OR BY ANY MEANS, ELECTRONIC OR MECHANICAL, INCLUDING PHOTOCOPYING, RECORDING, OR BY ANY INFORMATION STORAGE AND RETRIEVAL SYSTEM, WITHOUT THE EXPRESS WRITTEN PERMISSION OF CALTECH AND JPL. THIS DRAWING IS PROVIDED AS IS AND WITHOUT WARRANTY OF ANY KIND. CALTECH AND JPL MAKE NO REPRESENTATION OR WARRANTY OF ANY KIND, EXPRESS OR IMPLIED, REGARDING THE ACCURACY, COMPLETENESS, OR SUITABILITY OF THIS DRAWING FOR ANY PARTICULAR PURPOSE. THE USER ASSUMES ALL LIABILITY FOR THE USE OF THIS DRAWING.</p>					
<p>APPROVALS</p> <p>DR. CAI 022409</p> <p>ENGR. JHOX 051106</p> <p>CHK. []</p> <p>APPD. []</p> <p>EFFECTIVE</p>		<p>DATE</p> <p>022409</p> <p>051106</p>			
<p>DO NOT SCALE DRAWING</p> <p>EXT ASSEMBLY</p>			<p>SCALE 2:1</p>		
<p>STEP 0 SEF8</p>			<p>REV. A</p>		
<p>DATE 051106</p>			<p>REV. A</p>		
<p>SCALE 2:1</p>			<p>REV. A</p>		
<p>SCALE 2:1</p>			<p>REV. A</p>		

4 3 2 1

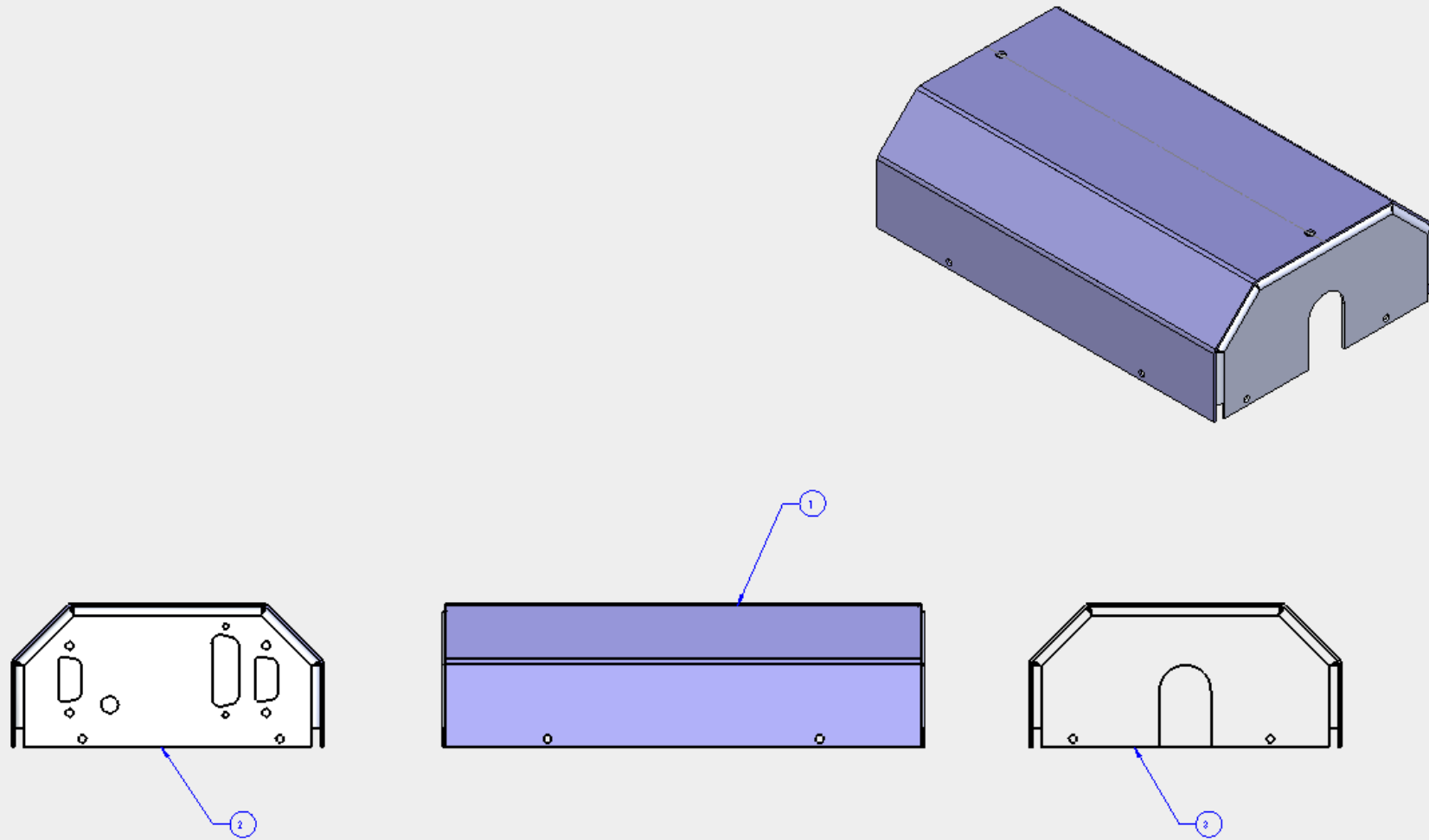

REV	PART NO.	DESCRIPTION	MATERIAL	SPECIFICATION	W.T.
4					
3	67708MTP-52	END PLATE			
2	67708MTP-51	END PLATE			
1	67708MTP-50	COVER, RF ENCLOSURE			

PROPRIETARY AND CONFIDENTIAL THIS DRAWING IS THE PROPERTY OF CALTECH AND JPL. IT IS TO BE USED ONLY FOR THE PURPOSES SPECIFIED HEREIN. ALL RIGHTS ARE RESERVED. INFORMATION CONTAINED HEREIN IS UNCLASSIFIED EXCEPT WHERE SHOWN OTHERWISE. REPRODUCTION IN WHOLE OR IN PART WITHOUT THE EXPRESS PERMISSION OF CALTECH AND JPL IS PROHIBITED.		APPROVALS DR. CAI 022409 ENGR. JHOX 061106 CDR. [blank] APPD. [blank] EFFECTIVE DATE [blank]		NATIONAL CENTER FOR ATMOSPHERIC RESEARCH 1560 TOWNSEND DRIVE BOULDER, CO 80506	
DO NOT SCALE DRAWING IN EXT ASSEMBLY		HIAPER RF ENCLOSURE ASSEMBLY MTP-H		REV. A	
SCALE 1:2		PART NO. 67708MTP-43		SHEET 1 OF 1	

4

3

2

1

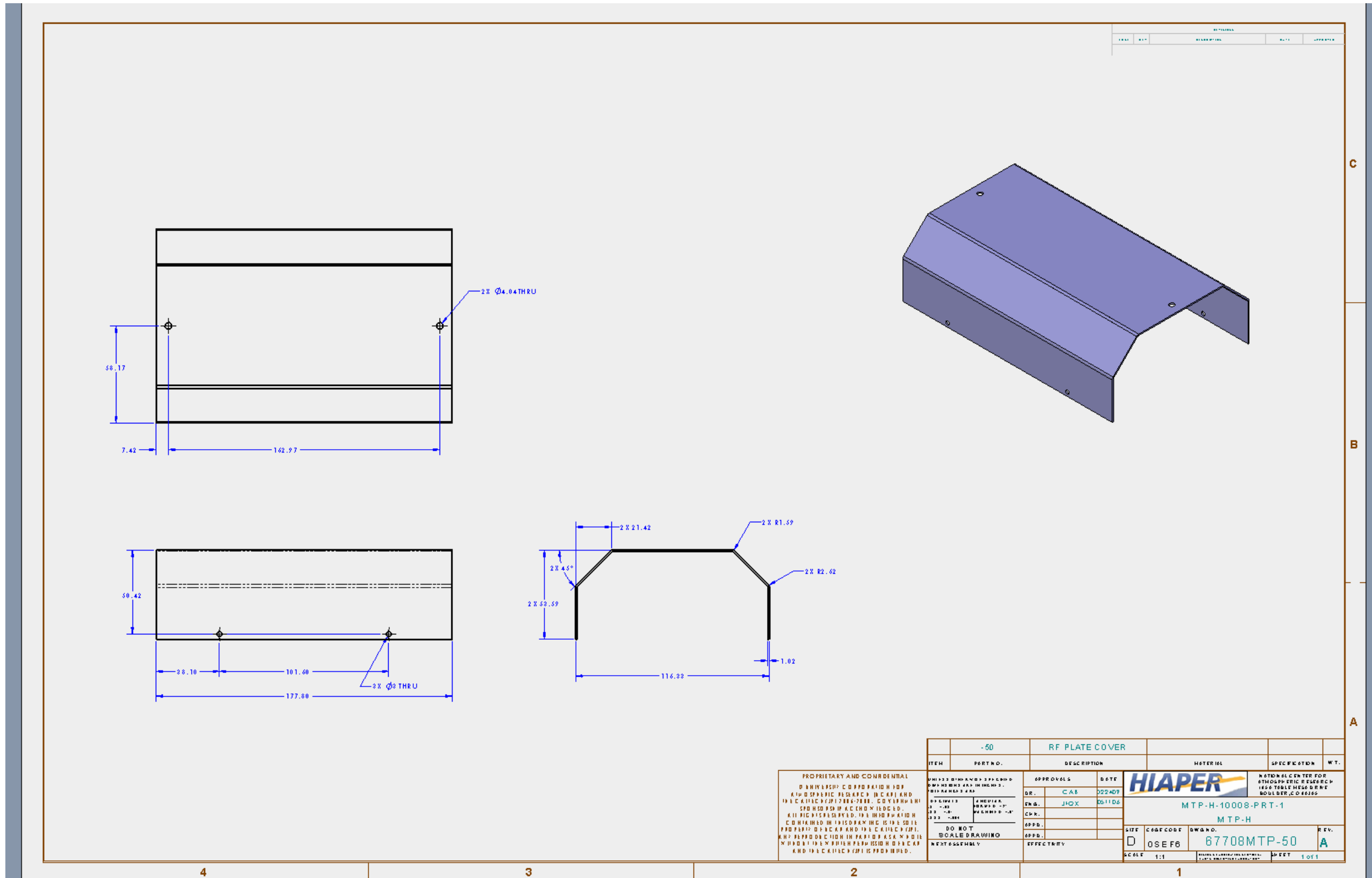

HALO MTP Design Package
 JPL/Caltech PROPRIETARY —Not for Public Release or Redistribution

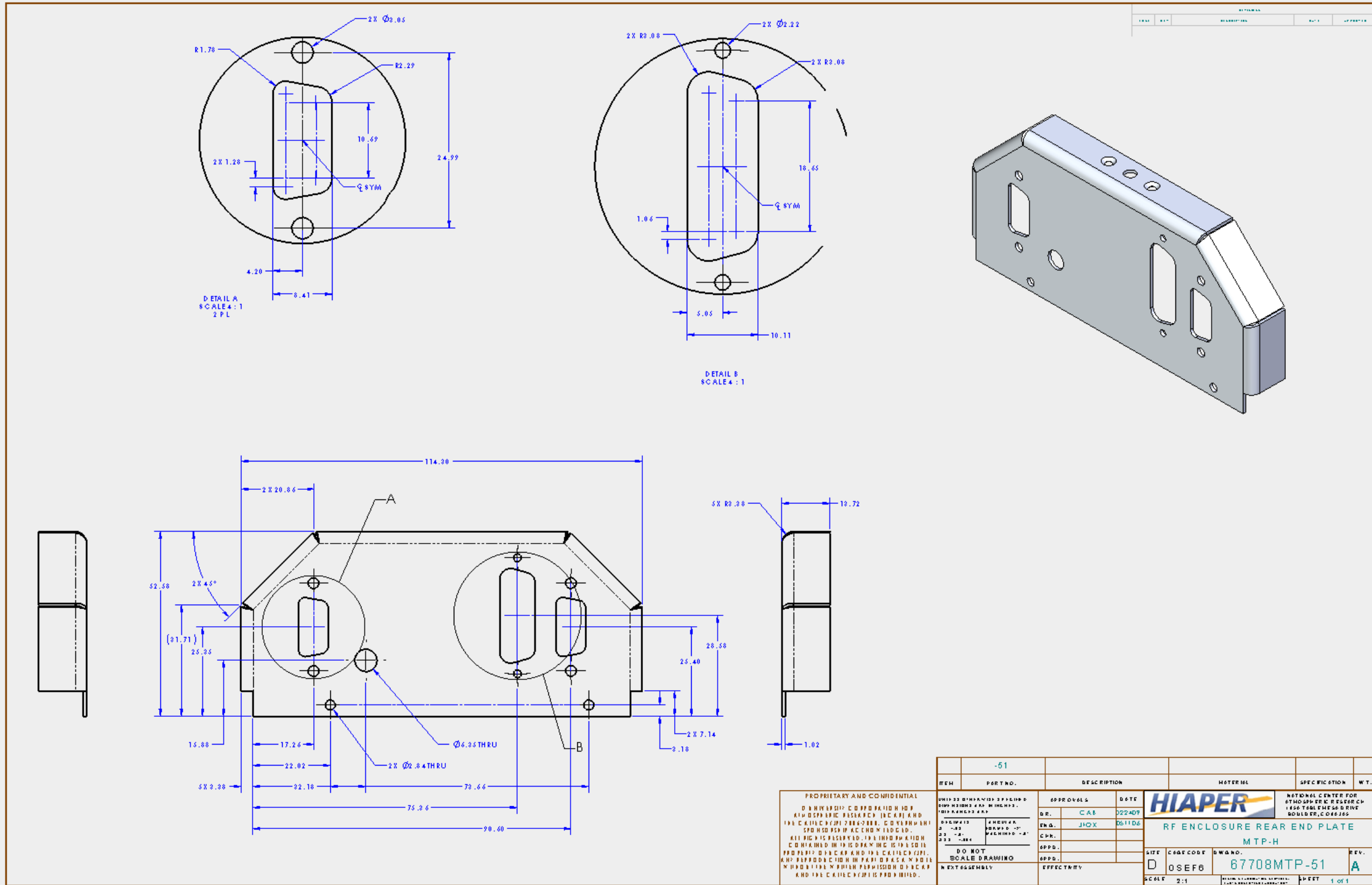

C
B
A

PROPRIETARY AND CONFIDENTIAL
 THIS DRAWING IS THE PROPERTY OF JPL/CALTECH AND IS NOT TO BE REPRODUCED OR TRANSMITTED IN ANY FORM OR BY ANY MEANS, ELECTRONIC OR MECHANICAL, INCLUDING PHOTOCOPYING, RECORDING, OR BY ANY INFORMATION STORAGE AND RETRIEVAL SYSTEM. ALL RIGHTS ARE RESERVED. INFORMATION CONTAINED HEREIN IS UNCLASSIFIED EXCEPT WHERE SHOWN OTHERWISE. THIS DRAWING IS THE PROPERTY OF JPL/CALTECH AND IS NOT TO BE REPRODUCED OR TRANSMITTED IN ANY FORM OR BY ANY MEANS, ELECTRONIC OR MECHANICAL, INCLUDING PHOTOCOPYING, RECORDING, OR BY ANY INFORMATION STORAGE AND RETRIEVAL SYSTEM.

REV	PART NO.	DESCRIPTION	MATERIAL	SPECIFICATION	W.T.
	-51				

APPROVALS	DATE
DR. CAI 022409	
ENGR. JHOX 061106	
CPR.	
APPR.	
EFFECTIVE	

SITE	CAGE CODE	DWG. NO.	REV.
D	0SEF8	67708MTP-51	A
SCALE	SHEET		1 OF 1
2:1			

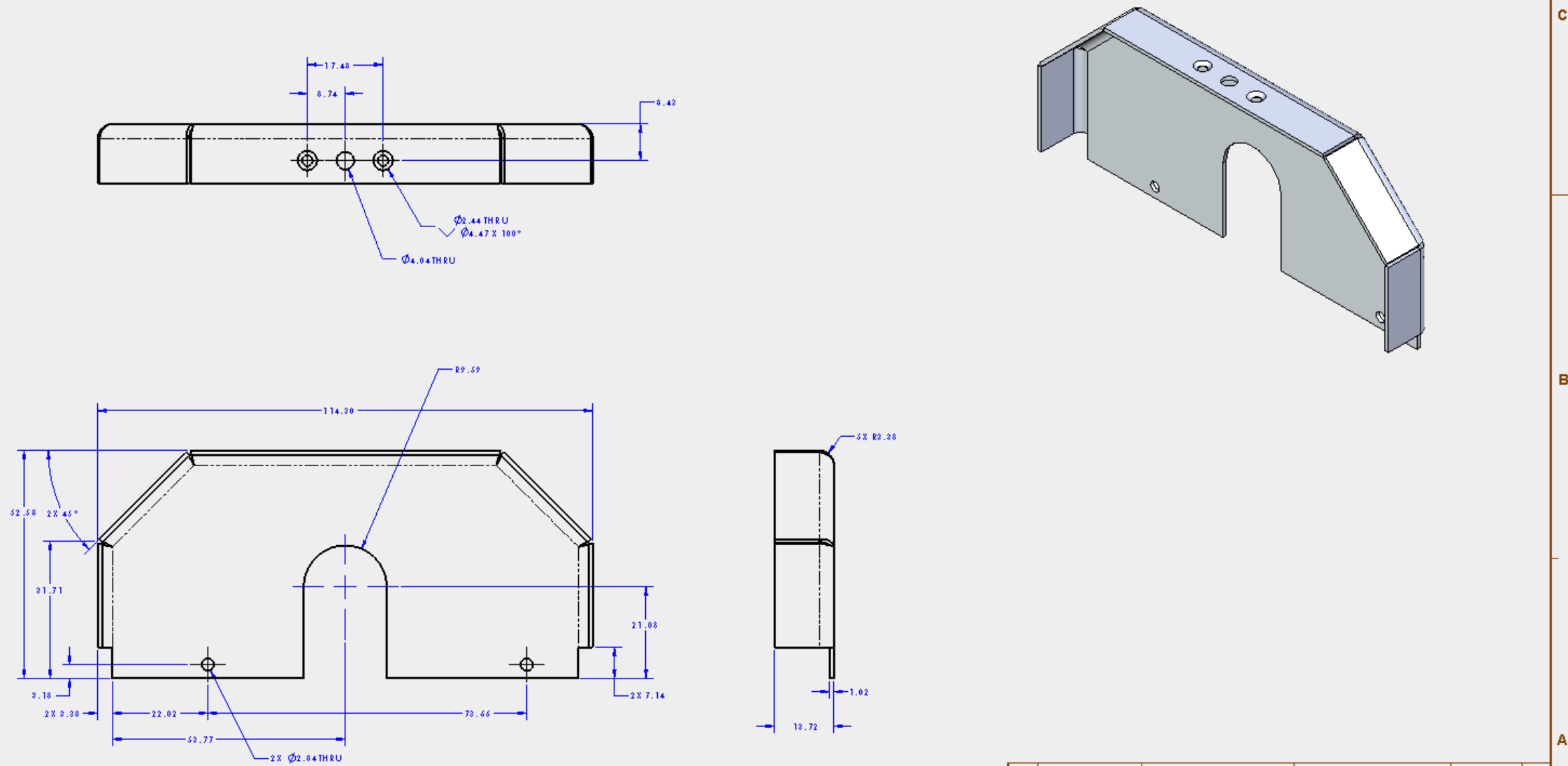

REV	PART NO.	DESCRIPTION	MATERIAL	SPECIFICATION	W.T.
	-52				
PROPRIETARY AND CONFIDENTIAL THIS DRAWING IS THE PROPERTY OF CALTECH AND JPL. IT IS TO BE USED ONLY FOR THE PURPOSES SPECIFIED HEREIN. NO PART OF THIS DRAWING IS TO BE REPRODUCED OR TRANSMITTED IN ANY FORM OR BY ANY MEANS, ELECTRONIC OR MECHANICAL, INCLUDING PHOTOCOPYING, RECORDING, OR BY ANY INFORMATION STORAGE AND RETRIEVAL SYSTEM, WITHOUT THE EXPRESS WRITTEN PERMISSION OF CALTECH AND JPL.		APPROVALS DR. CAL 022409 ENGR. JHOX 061106 CDR. [blank] APPD. [blank] EFFECTIVE	DATE 022409 061106	NATIONAL CENTER FOR ATMOSPHERIC RESEARCH 1560 TORRENS BLVD BOULDER, CO 80506	
DO NOT SCALE DRAWING IN ASSEMBLY		RF ENCLOSURE FRONT END PLATE MTP-H		REV. A	
SITE: D CASE CODE: 0SEF8		DWG NO.: 67708MTP-52		SCALE: 2:1 SHEET: 1 OF 1	

4

3

2

1

20 END OF DOCUMENT