



# HAC-UEM Ultra Low Power Data Radio Module

Version 1.0



**SHENZHEN HAC TELECOM TECHNOLOGY CO., LTD**

**Address** : 3rd Area, 19<sup>th</sup> Fl, Tower A, HaiSong Building, Tai Ran 9<sup>th</sup> Rd,  
Futian, ShenZhen, China.

**Tel** : +86-755-23981078 23981077

**Fax** : +86-755-23981007

**E-mail** : webmaster@haccomm.com

**Website** : <http://www.haccomm.com>

## **I. Features of HAC-UEM ultra Low Power Data Radio Module**

1. Ultra low power transmission with 100mW as maximal transmission power.
2. Requiring no any frequency, HAC-UEM transceivers work on ISM frequency band and carrier frequency is 433MHz.
3. High anti-interference and Low BER (Bit error Rate)  
Based on the Gaussian Frequency Shift Keying (GFSK) modulation, the high-efficiency forward error correction channel encoding technology is used to enhance data's resistance to both transient interference and random interference and the actual bit error rate of  $10^{-5} \sim 10^{-6}$  can be achieved when channel bit error rate is  $10^{-2}$ .
4. Long Transmission Distance  
Within the visible range, when the height of antenna is higher than 2m and The Bit Error Rate (BER) is  $10^{-3}$ , the reliable transmission distances respectively is 2000m @1200bps, >1200m@9600bps and >400m@38400bps.
5. Transparent data transmission  
Transparent data interface used in transceivers is for meeting many standard or nonstandard user protocols. Any false data generated in air can be filtrated automatically (What has been received is exactly what has been transmitted).
6. Multi-channels  
HAC-UEM transceivers offer Multi-channels in one ISM frequency band satisfying various configuration of communication under user's demand at the same time and avoiding the interference by other devices in the same locale. (Channels setting is set via serial port command, please see the concrete method in Page6)
7. 1 port with three connection methods  
HAC-UEM transceivers provide 1 port with three connection ports: a UART interface of TTL level, a standard RS-232 port and a RS-485 port, but they are asynchronous, so only one port available once.
8. Intelligent data control and no any complicated transmission programs required  
Even for half duplex communication, no any excessive programs required. All RF system data transmission/reception and other On-the-Fly conversion and control are performed by HAC-UEM transceivers automatically.



9. Lower power consumption & Sleep function

The receiving current is <45mA, the transmitting current is <130mA @100mW (60mA@10mW), and the sleeping current is <5uA(Sleep mode controlled by user).

10. High reliability, small and light

By using monolithic radio-frequency integrated circuit and single-chip MCU, the transceivers have little peripheral circuits, high reliability, and low failure rate.

11. More options of configurable antennas for user different applications.

## II. Applications of series HAC-UEM ultra low power data radio module

HAC-UEM Series Ultra low power data radio module is suitable for:

- \* Auto Meter Reading system.
- \* Remote control and monitoring.
- \* Data collecting in product lines.
- \* Data communication used for railway, oil field, dock and army.
- \* Medical and electric equipments control.
- \* light and home appliances intelligent control.
- \* Security alarm and monitoring control.
- \* Check attendance system and positioning in coal mine.
- \* Car burglar proof, pressure detecting of the wheel, four-wheel orientation.
- \* Wireless POS in shops.
- \* GPS system.
- \* LED display in thruway and public places.
- \* Queue-management system in bank and government.
- \* Smart wireless PDA terminal for restaurant ordering system and voting system.
- \* telemetry system.

## III. How to use HAC-UEM series ultra low power data radio module

HAC-UEM is a member of HAC series ultra low power data radio modules, which provides RS-232, RS-485 and UART/TTL level interface port for direct connection with PC, RS485 devices, monolithic processors and other UART components kind of applications. The schematic diagram is shown below:

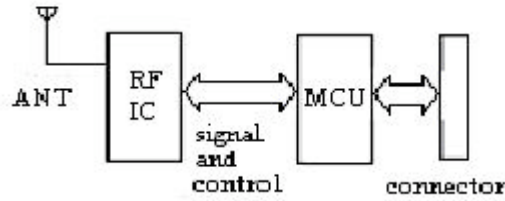

**HAC-UEN principle map**

**1. Power supply**

The factory default setting is +4.75~5.25V DC. By using better ripple factor (the ripple peak should be <10mV), HAC-UEM transceivers can also share power supply with other equipment. If possible, a voltage-stabilizing chip with 5V voltage is more recommended as the only power supply than Switch power supply. But if only switch power supply available, the jam by switch pulse to the transceivers should be avoided. In addition, the reliable grounding must be used if there is other device in the system equipment. In case of failing to connect with the ground, it can form its own grounding but must be absolutely separated from the municipal electric supply.

If the transceivers with lower power and lower consumption are required, we can lower the power supply into +3V.

**2. Connection Definition with terminal**

HAC-UEM transceivers supply one 10-pin connector (JP1), and one 2-pin positioning connector (JP2). Both two Pins of JP2 are connected with the ground. Their definitions and connection methods with terminals are shown in Table 1.

**Table 1: Pin Definitions and connection methods**

Pin	Signal Name	Function	Level	Connection with terminal	Remarks
1	GND	Ground		Ground	
2	VCC	Power supply DC	+4.75~5.25V		
3	RxD/TTL	Serial data input to the transceiver	TTL	TxD	
4	TxD/TTL	Transmitted data out of the transceiver	TTL	RxD	

5	SET_EN	Setting enable	TTL		
6	<u>RESET</u>	Reset (input)	TTL		Negative pulse reset
7	SLEEP	Sleep control (input)	TTL	Sleep signal	High level sleep
8	B(TxD)	B of RS-485 (TxD of RS-232)		B(RxD)	
9	A(RxD)	A of RS-485 (RxD of RS-232)	TTL	A(TxD)	
10	GND	Ground		Gound	

**3. The connection schematic diagram of HAC-UEM transceivers with terminal.**

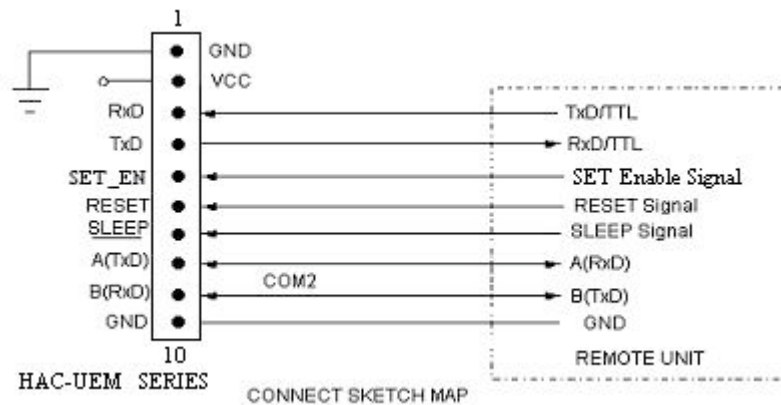

**4. The Function-indicator light**

- a. The LED indicator light glitters for 0.5S once after switched on.
- b. The LED indicator light glitters continually while receiving data from air.
- c. The LED indicator light will light on continuously when the transceiver transmits data into air after receiving from COM.
- d. The LED indicator light glitters continually but darker, when the transceiver is in setting mode.

**5. Function settings**

A simple configuration based on user's needs should be made to validate the channel frequency, interface data rate, data format, sleep function and transmission power. The UEM\_studio software and the setting board provided by HAC can be used.

Also, users can program setting software by themselves, but the control of setting enabling (SET\_EN) should be a strong consideration while programming. When being idle and SET\_EN set in low level, 1ms later HAC-UEM transceivers will be in setting mode; When SET\_EN set in high level, 100ms later the transceivers will turn into work mode.

**Timing Diagram:**

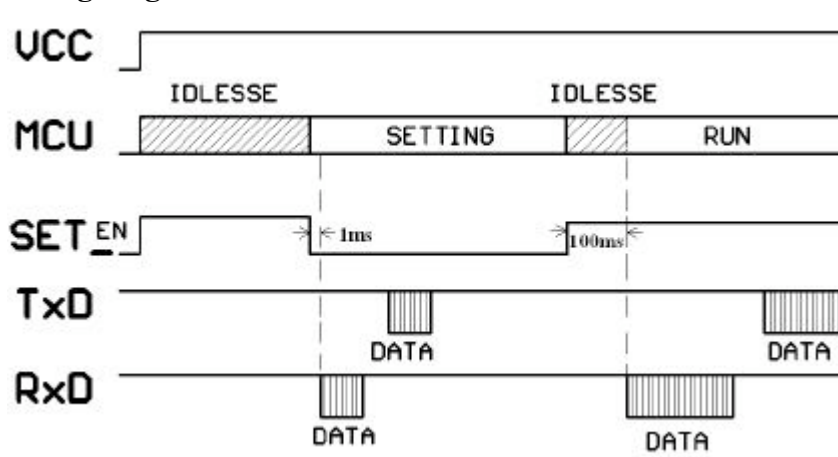

**The factory set default of HAC-UEM is as following:**

- a. Channel: NO.7
- b. The serial interface data rate equals the RF baud rate
- c. Data format: 8E1
- d. Sleep function: closed
- e. Transmission power: 100mW

**The user's other specific requirement will be set before leaving factory.**

**The concrete Setting methods are following:**

- a. Interface and data format

Via the COM port, the basic parameter can be set using ASCII code or Hex. (**Note: when getting in setting mode, the baud rate - 9600bps and the data format - 8N1 are both fixed).**

- b. Command format:

	Identifier	Read-write sign	Command word	Parameter	End code
ASCII	\$	R / W	1byte	n byte	↵ (Enter)



Hex	24	52/57	1byte	n byte	0D
-----	----	-------	-------	--------	----

- Identifier: \$- Command starts
- Read-write sign: R-read parameter, W-write parameter
- Command word: C-channel Number, V-verifying code, B-baud rate, S-sleep function
- Parameter: Refer to command paraphrase
- End code: Enter -ending sign command (0D)

There is no distinction between capitals and small letters in entire commands. If wrong input occurs, by pressing Backspace (08) the last byte can be deleted and the command can be input again.

c. Command paraphrase

- Read the current :

Input command:

ASCII	\$R↵
Hex	24 52 0D

Return:

ASCII	<p>KD (The baud rate range of A、B、C、D、E、F is 1200~38400bps)</p> <p>Channel: 0 (Channel No.: 0~7)</p> <p>Verifying: 8E1 (Parity bit: 8E1/8O1/8N1)</p> <p>Baud rate: 1200 (Baud rate: 1200~38400bps)</p> <p>Sleep: Close (Sleeping function: Close/Open)</p>
Hex	<p>4B 44 0D 0A</p> <p>20 20 43 68 61 6E 6E 65 6C 3A 20 30 37 0D 0A</p> <p>20 20 20 56 65 72 69 66 79 3A 20 38 65 31 0D 0A</p> <p>42 61 75 64 20 72 61 74 65 3A 20 31 32 30 30 20 0D 0A</p> <p>20 20 20 20 53 6C 65 65 70 3A 20 43 6C 6F 73 65 0D 0A</p>

- To write the Channel:

Input the command:

ASCII	\$WC07↵
Hex	24 57 43 30 38 0D

Return:



ASCII	Channel: 7 (Channel No.: 0~7)
Hex	20 20 43 68 61 6E 6E 65 6C 3A 20 30 37 0D 0A

**Note:** The new channel No. is 7. '\$WC' is the command for writing channels with parameter 00~07. When the channel number is less than 10, the anterior '0' cannot be omitted.

● To write the parity bit:

Input command:

ASCII	\$WVE ✓
Hex	24 57 56 45 0D

Return:

ASCII	Verify: 8E1
Hex	20 20 20 56 65 72 69 66 79 3A 20 38 65 31 0D 0A

**Note:** The parity bit set as 8E1. '\$WV' is the command for writing channels with parameter N、O、E, which respectively represent 8N1、8O1、8E1. 8 and 1 mean there are 8 efficient data bits and one start bit with one stop bit.

● To write the baud rate:

Input command:

ASCII	\$WBD ✓
Hex	24 57 42 44 0D

Return:

ASCII	Baud rate: 9600
Hex	42 61 75 64 20 72 61 74 65 3A 20 39 36 30 30 20 0D 0A

**Note:** The baud rate set as 9600bps. '\$WB' is the command for writing channels with parameter A、B、C、D、E、F, which respectively mean: 1200bps, 2400bps, 4800bps, 9600bps, 19200bps, 38400bps.

● To write the sleep parameter:

Input command:

ASCII	\$WSO ✓
Hex	24 57 42 44 0D

Return:

ASCII	Sleep: Open
-------	-------------





Hex	20 20 20 20 53 6C 65 65 70 3A <b>20 4F 70 65 6E 20</b> 0D 0A
-----	--

**Note** : Open the sleep function. '\$WS' is the command for writing channels with parameter **O,C and other characters**, which respectively represent opening the sleep function (Open) and closing the sleep function(Close).

●To write the command of error:

When any error occurs in identifier、read-write sign、command word, please press 'Backspace':

ASCII	Error!
Hex	45 72 72 6F 72 21 20 0D 0A

When nothing wrong with identifier, read-write sign, but command sign wrong, return:

ASCII	Error!
Hex	( <b>command sign:</b> ) 45 72 72 6F 72 21 20 0D 0A

**Note**: Red words are setting parameter, different setting leads to different return character.

## 6. Channel Frequency:

Channel No.	Frequency	Channel No.	Frequency
0	430.2000 MHz	4	434.6940 MHz
1	431.4288MHz	5	434.2332 MHz
2	431.7360 MHz	6	433.1580 MHz
3	430.5072 MHz	7	433.9260MHz

**Note**: Each channel frequency can be modified freely before leaving factory to meet user's needs.

## 7. Interface ports use:

Normal HAC-UEM transceivers provide UART interface port of TTL level. If RS232-port and RS485-port required, one port should be validated when making orders.

**The default of interface port is UART of the TTL level.**

The interface level can be changed by user if it is wanted and conditioned, the concrete

methods are following:

a. TTL to RS-232:

Weld U1(MAX232)、R4 (0Ω)、C1~C4(1uF)、C5 (10nF)

b. TTL to RS-485:

Weld U2(MAX485)、R4 (0Ω)、R5~R7(10K)

c. RS232/ RS485 to TTL:

Remove all components mentioned in above Term ‘a’ and ‘b’ on the rear side of the transceiver.

d. RS232 Vs RS485:

First, to implement Term ‘c’, then implement Term ‘a’ when RS232 wanted, or implement Term ‘b’ when RS485 needed.

**Modifying diagram is below:**

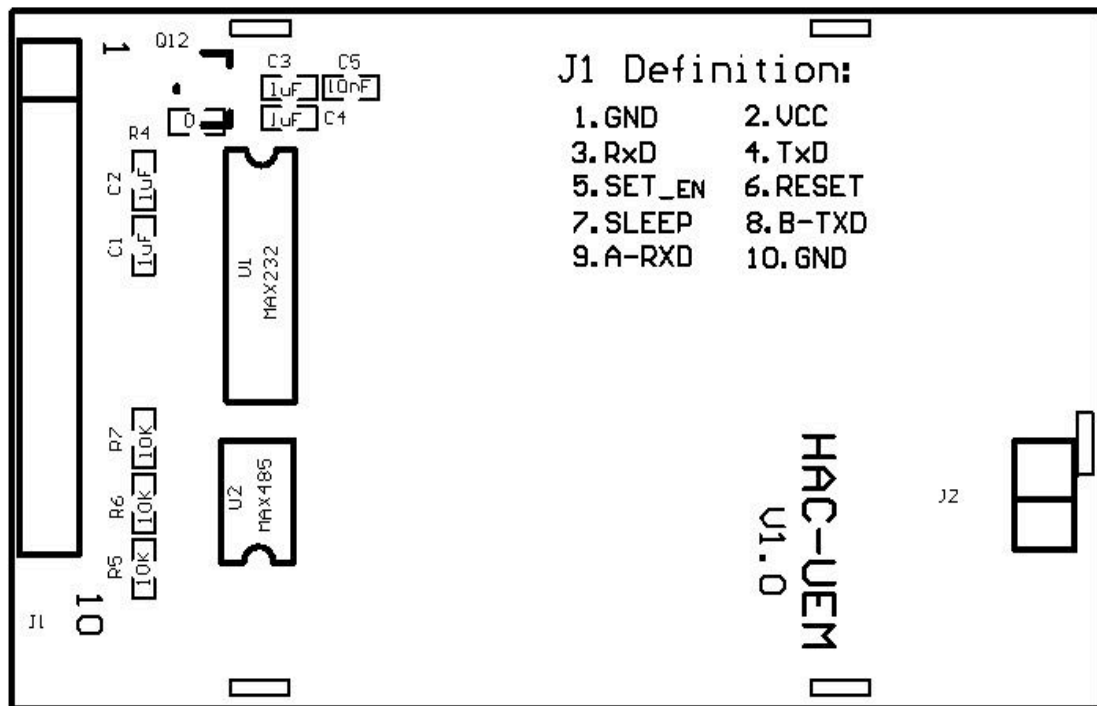

**8. Sleep function instruction:**

Due to reducing more consumption, HAC-UEM transceivers support Sleep function. In sleep mode, the current consumption is < 5uA.

The default set of sleep function is usually closed to ensure the reliability of preventing transceivers from getting in wrong sleep mode. The sleep function can be opened by HAC after informed or by user via programming them software (please see the function set detail in Article

5 in chapter 3).

a. How to use the Sleep function:

The Pin7 ‘SLP’ in JP1 is the signal of sleep control. In high power level, when the transceiver stays in sleep mode, the conversion from idle mode to sleep will be finished in 1ms. The SLP signal can convert transceiver from idle to sleep mode in 1ms after rising edge. If the Sleep signal arrives when the transceiver is transmitting data, the module will enter sleep mode after finishing transmission. From sleep mode to idle, it takes the transceiver 10ms after falling edge.

To disable the opened sleep function of HAC-UEM, the SLP (SLEEP) pin should be definitely connected with 0 or ground.

b. Attentions about use of sleep function:

When the sleep function enabled, any supply glitches, such as switch dithering, fire striking or quick switching on and off, could cause the transceiver to be switched to the wrong sleep mode. After switching on, users can avoid this error by making a compulsive restoration once after the CPU delays 100ms.

**Sleep Timing Diagram:**

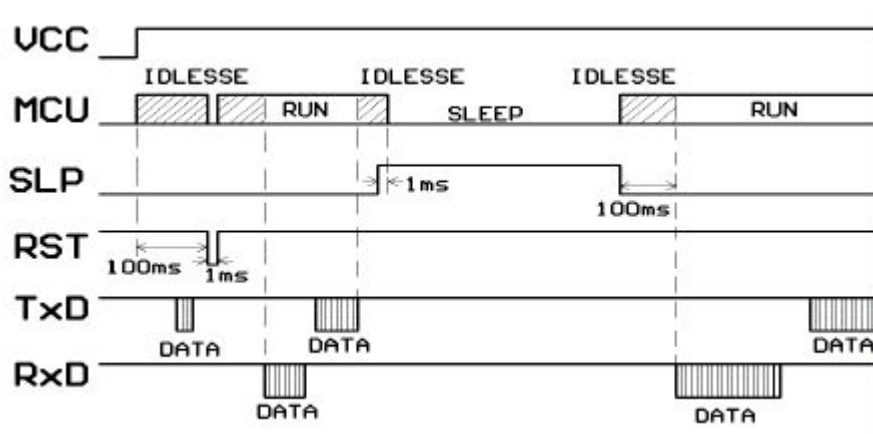

**9. The baud rate of data transmission:**

a. The relationship between the serial interface data rate and the RF data rate

To achieve the best result of communication, the RF data rate of HAC-UEM transceiver is concerned with parameters of components, and fixed after leaving factory, but the serial



interface data rate can be set by users themselves to modulate their equipment easily. So in type editing, the number after 'UEM' is the RF data rate, for example:

**Type:** HAC-UEM12 represents the RF data rate is 1200bps.

HAC-UEM192 represents the RF data rate is 19200bps

The types we currently have are following:

HAC-UEM12

HAC-UEM24

HAC-UEM48

HAC-UEM192

HAC-UEM384

The serial interface data rate in HAC-UEM transceivers ranging from 1200bps to 38400bps (user optional) is different from the RF data rate. However, the speed in actual data transmission and the distance both depend on the RF data rate. Lower the RF data rate is, farther the distance will be and slower the speed will be. Whereas, shorter the distance will be achieved and faster the speed will be. When the serial interface data rate is faster than the RF data rate, and since RAM buffer in transceivers is limited, the data will mostly overflow from buffer to be missed if users transmit a great deal of data. So under this situation, users are not recommended to send big data packages. Please see the maximal packages detail for once in table 5:

**Table 5: The maximal data packages when the serial interface data rate > the RF data rate**

TYPE	INTERFACE DATA RATE	MAXIMAL DATE PACKAGES
HAC-UEM12	2400bps	500Bytes
	4800bps	400Bytes
	9600bps	300Bytes
	19200 bps	240 Bytes
	38400 bps	240 Bytes
HAC-UEM24	4800bps	500Bytes
	9600bps	400Bytes
	19200 bps	300 Bytes
	38400 bps	240 Bytes
	9600bps	500Bytes

<b>HAC-UEM48</b>	<b>19200 bps</b>	<b>400 Bytes</b>
	<b>38400 bps</b>	<b>300 Bytes</b>
<b>HAC-UEM96</b>	<b>19200 bps</b>	<b>500 Bytes</b>
	<b>38400 bps</b>	<b>400 Bytes</b>
<b>HAC-UEM192</b>	<b>38400 bps</b>	<b>500 Bytes</b>

b. The delay time ( $t_c$ ) of conversion between transmitting and receiving is less than 1ms.

**Timing diagram:**

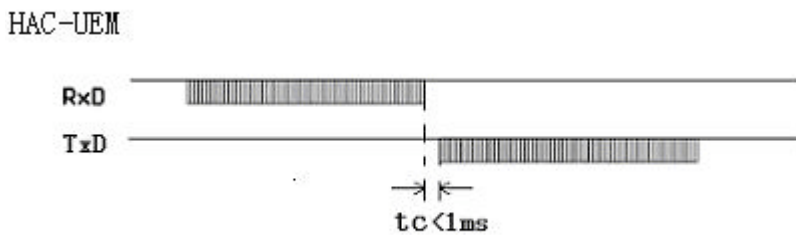

c. The delay time of transceivers between the first bit sent by Tx0 to the first bit received by Rx0.

Due to a data processing will be made on user's data by HAC-UEM transceiver using FEC (Forward Error Correction) or other correction algorithm, when Rx0 of a HAC-UEM transceiver 'A' receives the data, then transmits it, the other one transceiver 'B' will have a delay ( $t_s$ ) to receive and transmit by Tx0. Different RF data rate causes different delay time. Please see the specific delay time below:

<b>Rf</b>	<b>Date</b>	<b>Rate</b>	<b>Delay</b>	<b>RF</b>	<b>Data</b>	<b>Rate</b>	<b>Delay</b>
	<b>( bps )</b>		<b>ts ( ms )</b>		<b>( bps )</b>		<b>ts ( ms )</b>
	<b>1200</b>		<b>90</b>		<b>9600</b>		<b>12</b>
	<b>2400</b>		<b>48</b>		<b>19200</b>		<b>6</b>
	<b>4800</b>		<b>24</b>		<b>38400</b>		<b>3</b>

**Timing diagram:**



d. Error dealing procedure:

To enhance the reliability and stability of user's systems, a verify bit or a Cyclic Redundancy Check (CRC) mode is highly recommended to resent the wrong information while using HAC-UEM series modules.

e. Large-number data transmission

In theory, when the interface data rate is faster than the RF data rate, HAC-UEM transceivers can send unlimited-long data package, but any long packages more than 120B are not recommended. The length of each package should be between 60~100B. We also recommend user to resent the wrong information using Automatic Error Request Equipment (ARQ).

**The analyzing as below:**

What if the actual transmission BER (Bit Error Rate) is  $10^{-4}$ , 1 packet with 1KB data, which is about 10-thousand bits, is sent, theoretically, at least 1 bit will be received wrongly, then the 1KB information will never be received correctly.

But if we package the data into 10 packets with 100B for each, when all 10 packets are sent, there will be only 1 packet wrong according to this probability. After that, resend this wrong packet using ARQ mode. So by resending one more packet and the efficiency rate is reduced 10%, all data will be absolutely received correctly.

f. Since a redundancy code is added for automatic correction in wireless transmission process, the actual RF transmission baud rate is faster than RF efficient baud rate. So the actual RF efficient baud rate is mostly ignored.

**10. Dimension diagram (Unit: mm):**

The dimension diagram below is the factory set default of HAC-UEM transceiver. Other required smaller sizes and different shapes can also be provided.

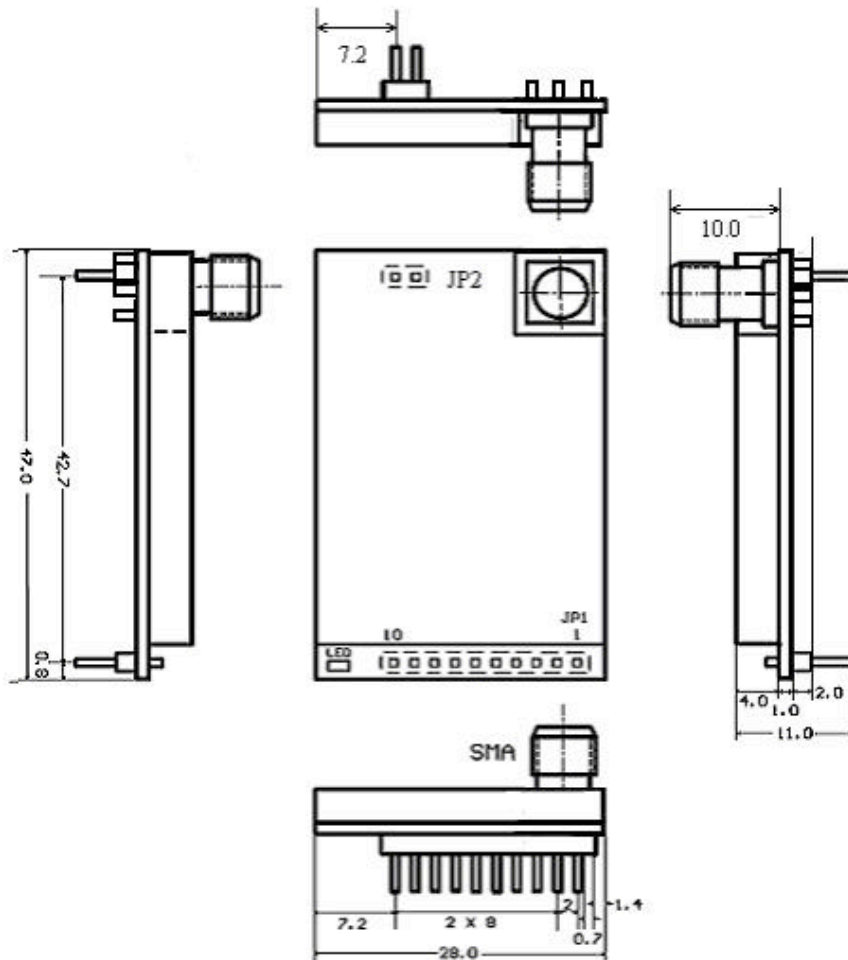

## 11. Supported protocol and Transmit capability

HAC-UEM standard transceivers offer transparent protocol to support various applications and protocols of users. If the user needs to decrease his cost or ease the workload of terminal CPU, we can add other specific functions based on the transparent protocol, such as addressing, data acquisition, command interpretation, etc.

## 12. Antenna configuration:

Many appropriate antennas for ultra low power RF modules are selected for meeting different user antenna configurations. Please ask our Sales office for further information about the antenna's dimension and performance. The main options of antennas are exterior flagelliform rubber antenna with helical SMA joint, magnetic car antenna, PCB antenna and spring antenna. If the user has special demands on antennas, we can design and produce for them specially.

- a. Helical SMA antennas: the type is HAC-LX433-10-SMA



- b. Magnetic vehicle antenna: the type is HAC-XP433S-300Y-SMA



- c. PCB antenna: the type is HAC-WD433-3



- d. Spring antenna: the type is HAC-TH433-B



#### **IV. Application of HAC-UEM series networking**

The communication channel of HAC-UEM is half duplex, which is mostly suitable for the

FAX:+86-755-23981007 TEL: +86-755-23981079 E-MAIL: [webmaster@haccom.com](mailto:webmaster@haccom.com) <http://www.haccom.com>





communication mode of point to multi-point. Under this mode, one master station must be set, and all of the rest are slave stations with a unique address. The coordination of communication is controlled by master station that uses data frames containing address code to transmit data or command. All of slave stations will receive the data and command and compare the received address code with local address code. If they are different, the data will be dismissed with no response. If they are same, it means the data is sent to the local. Slave station will make different responses according to the transmitted data or command and send the data back as response. All these jobs must be performed by upper level protocol, which will assure that there is only one transmitter-receiver in transmission mode in the communication network at any transient moment so as to avoid the cross-interference.

HAC-UEM transceivers can also be used for point-to-point communication with easier operation. For the programming of serial port, all you have to do is to remember that its communication mode is half duplex and always to observe the time sequence of come-and-go for receiving and transmitting.

## V. Technical index of HAC-UEM

Modulation mode	: GFSK(Gaussian Frequency Shift Keying)
Working frequency	: 429~438MHz(402~470MHz available for customization)
Interface data format	: 8E1/8N1/8O1
Transmission power	: 100mW or 20dBm (10mW~100mW available for special request)
Receiving sensitivity	: -122dBm@UEM12 -118dBm@UEM96 -102dBm@UEM384
RF data rate	: 1200/2400/4800/9600/19200/38400bps(must be validated before leaving factory)
Interface baud rate	: 1200/2400/4800/9600/19200/38400bps(optional)
Humidity	: 10%~90% relative humidity without condensation
Temperature	: -10°C~60°C (commercial, which is factory set default, 'C' should be added in type. ) -35°C~75°C( Industrial, 'I' should be added in type),
Power supply	: +4.75 ~ 5.25VDC( 3V optional)
Transmitting current	: ≤130mA @100mW, ≤60mA@10mW(optional)



- Receiving current :  $\leq 45\text{mA}$
- Sleeping current :  $\leq 5\mu\text{A}$
- Channel bandwidth : 12.5KHz@ UEM12  
25KHz @ UEM24  
50KHz@ UEM48  
50KHz@ UEM96  
100KHz@ UEM192  
200KHz@ UEM384
- Adjacent Channel Inhibition Ratio :  $\geq 65\text{dB}$
- Mirror Inhibition Ratio :  $\geq 80\text{dB}$
- Obstructed :  $\geq 80\text{dB}$
- Dimension : 47.0mm×28.0mm×7.0mm (without antenna base)
- Weight : 25g (without antenna base)

## VI. Explanation of type Name

- ‘HAC’ - Shenzhen HAC Telecom Technology Co., Ltd
- ‘UEM’ - The name of type, ‘U’ - Ultra power, ‘E’ - Enhanced type of ‘UM’, UEM has better performance, nicer power, sensitivity, spectra and approval CE.
- ‘96’ - The RF data rate of 9600bps; ‘12’-1200bps, etc.
- ‘I’ - Industrial. The factory set default of HAC-UEM transceiver is Commercial degree
- ‘R’ - Approval RoHS (non lead product), only available for volume orders
- ‘433’ - The frequency range 429~438MHz
- ‘T’ -TTL/UART port as the default setting; ‘2’ - RS232, ‘4’- RS485 (Chip MAX232 or MAX485 need to be added if port RS232 or RS485 required)

