

0.1 GOES / GMS Transmitter

SE110 Version Serial Connector Wiring

Note: EVE serial port “tyCo/3” is normally used for the GOES/GMS transmitter. This can be changed in the EVE configuration via the “GOES” command. Refer to the EVE Manual for more information about the command’s syntax.:

RJ-45 Connector:

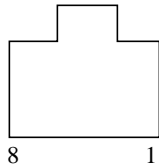

Front View of Female Socket

EVE RJ-45	Signal	GOES/GMS	Color	Alt.-Color
1	RI		Blue	Brown
2	DCD		Orange	Blue
3	DTR		Black	Yellow
4	Gnd	J	Red	Green
5	Rx ←	A	Green	Red
6	Tx →	C	Yellow	Black
7	CTS	H	Brown	Orange
8	RTS	B	Gray	White

Wiring for connecting the cable to a PC:

EVE RJ-45	Signal	GOES/GMS	DB25	DE9
1	RI			
2	DCD			
3	DTR			
4	Gnd	J	7	5
5	Rx ←	A	3	2
6	Tx →	C	2	3
7	CTS	H	5	8
8	RTS	B	4	7

SE120 Version Wiring (New Transmitter Version 2001)

Color?	Signal	EVE RJ-45	GOES/GMS 14-Pin Ribbon	Color?
-----	-----	-----	-----	-----
Blue	RI	1		
Or.	DCD	2		
Blk	DTR	3		
Red	Gnd	4	←→ 2,4,6	Wht/Brn/Or
Grn	Rx	5	← 14	Brown
Yel	Tx	6	→ 13	Black
Brn	CTS	7	← 12	White
Gray	RTS	8	→ 11	Gray
	NC		1,3,5	Gray,Blk,Red
	Reserved		7,8	Yel,Grn
	Reserved		9,10	Blue,violet

Power Wiring

The GOES power connector needs up to 3.5 amps at 12V.

The connector should go to plug “J22” on the electronics box front panel. The other power plugs near J22 are fused and could blow during a transmission unless care is taken to select a sufficiently rated fuse. Note, pin 1 on J22 is +12VDC provided by the battery and pin 2 is return.

Connector (SE120/1200): Amp/Tyco p/n 1-480318-0 Available through Digikey

RF Output Connections.

The GOES RF output is fed through a bulk-head “N” connector. From there a short length of “RG8” cable is used to connect to the antenna. *The transmitter should not be programmed to send a message or raw carrier signal through the RF output unless either an antenna or a dummy load element on a watt-meter or else some other 50-ohm load termination is provided.*

GMS Transmitter Connections

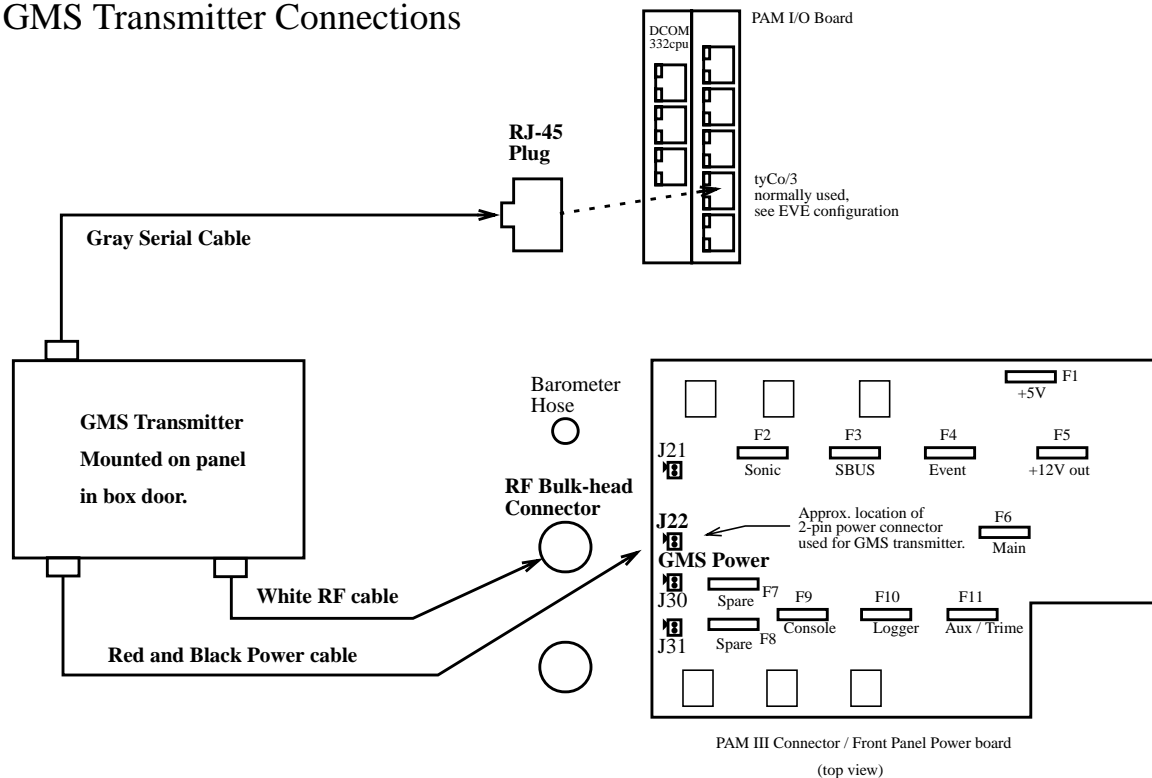

Supply Voltage Comparitor Fail-safe Circuit

The SE110 GOES/GMS transmitter includes an output power feedback circuit which is used to stabilize the output to within the specified limits. Upon initiation of a transmission, the transmitter measures the supply input voltage in order to make sure that the control voltages do not drift too far out and cause RF to go out of specification limits. If the control voltages are outside of their limits, the transmitter automatically shuts down the transmission. This will happen in a situation where the remote station’s battery is excessively drained and cannot supply enough power for the transmission to take place.

Under normal circumstances, the comparator circuit should never need to be checked and the transmitter should never be opened, however, if the station is experiencing an abnormal, early shutdown of transmissions, or is failing to send a message, a qualified technician can verify the comparator circuit. The circuit location is:

Near the TCXO...IC 'U7' a Max707

Pin 4 is input from a resistor divider from the supply side. These resistors are: R5 and R6 on the reverse side of the board. They should be 90.9K and 681K 1% tolerance values respectively. Pin 5 is the comparator output (0,+5) that goes to the microprocessor which controls transmission. The Trigger level should be about 10.7-11.0 VDC on the supply. This trigger is always powered up so you won't need to actually transmit to check where it fires off. The SE110 software samples for the comparator trigger level after initial power up. *Self Test Alternative for checking the voltage set point:* status bit #2 of byte number 1 reported by the self test indicates whether the low-voltage signal has toggled. This can be used on the bench to determine if the trigger has fired incorrectly.