

## 0.3 NCAR BandPass Hygrothermometer (BPH)

### *Sections Include:*

- Section 0.3.1, "Description:," on page 1*
- Section 0.3.2, "50Y Probe:," on page 1*
- Section 0.3.3, "Cable Interface:," on page 2*
- Section 0.3.4, "Housing:," on page 4*
- Section 0.3.5, "Ventilation Fan:," on page 5*
- Section 0.3.6, "Installation:," on page 5*
- Section 0.3.7, "Calibration:," on page 5*
- Section 0.3.8, "Maintenance:," on page 6*
- Section 0.3.9, "Troubleshooting:," on page 6*
- Section 0.3.10, "Sensor/Fan replacement:," on page 7*

### **0.3.1 Description:**

The PAM III Bandpass Hygrothermometer, BPH, is used to compute moisture flux in conjunction with a sonic anemometer by using Tom Horst's Bandpass Covariance technique for estimating high-frequency fluxes based on co-spectral similarity with the slow-response data provided by the BPH. The technique and instrument is no longer being used by NCAR/SSSF due to availability of reliable high-frequency response hygrometers.

The BPH instrument is built around the Vaisala 50Y temperature/humidity probe housed in a dual tube radiation shield with forced ventilation. The output signals of the instrument are provided as analog signals ranging from 0 to 1 volt. The analog output signals are connected to 2 A/D channels on the PAM III data acquisition system, and converted to a digital format.

### **0.3.2 50Y Probe:**

The BPH uses a Vaisala 50Y humitter probe to measure temperature and humidity. The probe includes a temperature and humidity transducer with signal conditioning electronics. The temperature transducer is a thin film platinum resistance device. Humidity is measured using a solid-state capacitance device. The sensing elements are protected from dust, direct moisture, and other contaminants by a membrane filter which will allow moisture vapor penetration.

The humitter provides an output voltage signal for each transducer. A simple linear transfer function can be applied to the output signal to convert to engineering units.

$$RH = V_{output} \times 100$$

$$T = V_{output} \times 100 - 40$$

Where  $V_{output}$  is over the range of 0.0 to 1.0 volts dc. The table below shows the range and accuracy specifications from the manufacturer. At NCAR, individual calibrations are done on each sensor to improve the overall accuracy. Refer to the section on calibration for additional information.

### 50Y Specifications

parameter	range	accuracy
temperature	-10° to 60° C	±0.8° C
humidity	10% to 90%	±3 %

### 0.3.3 Cable Interface:

More than one type of cable has been used to interface the BPH. The original NCAR version included a 6-pin Lemo connector mounted on the BPH housing but that implementation was discarded. The newer GAME program versions include a 9-pin Amp connector on the BPH housing and a 10 meter cable used to interface the sensor to the PAMIII electronics box analog input port AD1 using a short 'PigTail' adaptor. GAME has also interfaced BPH sensors directly to a Gill R3 SUI. Typically this has utilized the existing 9-pin Amp connector on the BPH housing, however this connector can be eliminated by wiring directly from the SIU to the 50Y/Fan as noted below. In all cases, power and output signals are provided through the same cable. Shielding is used around the signal lines to reduce noise from the power lines.

### Standard BandPass Hygrometer Cabling Using EVE A/D Board

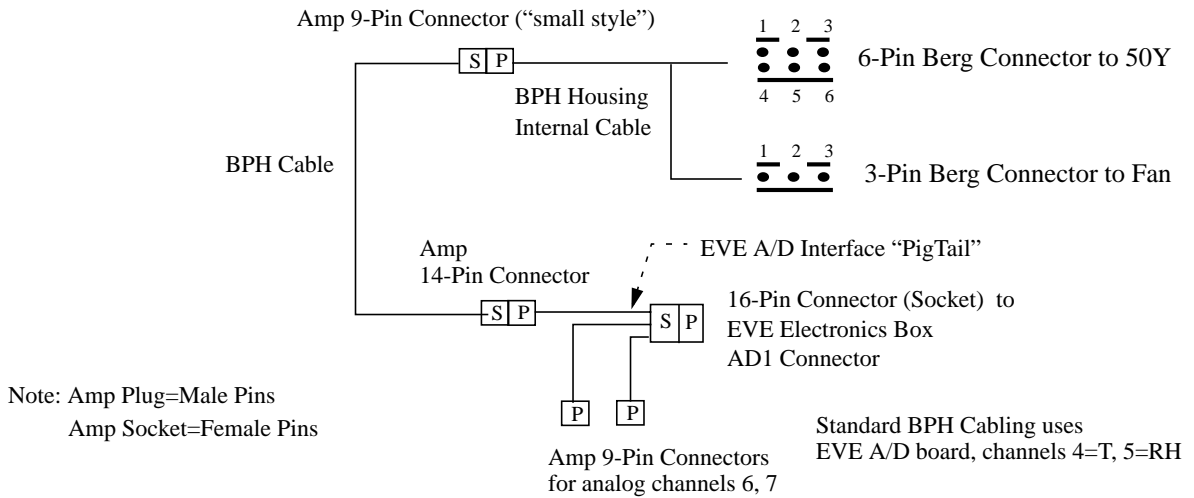

50Y	Berg 6-Pin Inside Housing to 50Y	AMP 9 pin on BPH Housing (Plug) / Cable (Socket)	AMP 14 pin cable to EVE AD Interface "PigTail"
Temp	4	1	1
GND	2	2	2
shield		3	3
RH	6	4	4
GND		5	5
shield		3	6
GND		7	9
+12 Vdc	3	8	8
shield		3	7
	Berg 3-Pin to Fan		
+12 Vdc (fan)	2	9	10
GND (fan)	1	6	11
shield			12
n/c			13
n/c			14

NOTE: (1) A common shield at the sensor is routed down the individual shields for each transducer response and power. The shields are attached at the sensor to ground. The shields SHOULD NOT be connected at the EVE electronics.

(2) The shield for the fan is not attached at the sensor; therefore, it can be attached at EVE.

### **EVE A/D Interface “PigTail” for BPH**

BPH SENSOR	BPH - AMP 14	A/D - Amp 16 pin
Temperature +	1	1
Temperature -	2	2
shield	3	
RH +	4	4
RH -	5	5
shield	6	
+12 Vdc	8	13
GND	9	14
shield	7	
FAN +12 Vdc	10	13
FAN GND	11	14
shield	12	
SPARE A/D Ch 6	AMP 9	
input +	1	7
input -	2	8
shield	3	9
+12 Vdc	8	15
GND	7	16
SPARE A/D Ch 7	AMP 9	
input +	1	10
input -	2	11
shield	3	12
+12 Vdc	8	15
GND	7	16

## GAME BandPass Hygrometer Cabling 50Y / Fan - Gill SIU

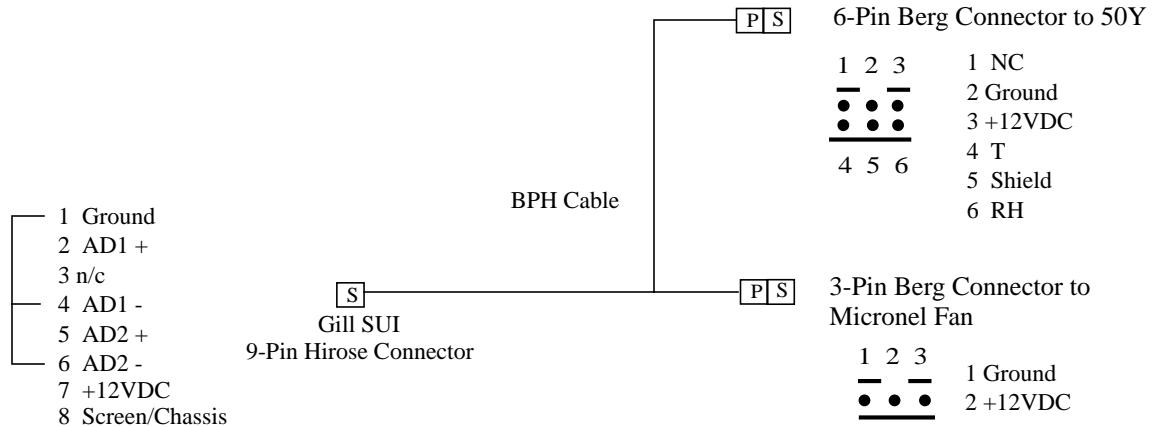

### 0.3.4 Housing:

The housing for the BPH is made up of 3 sections; the inlet tube, the fan housing, and the exhaust tube. The BPH housing provides an air sample to the transducers which is representative of the ambient air in close proximity of the sonic sensor. In order to accomplish this the sources of radiation must be accounted for and if possible eliminated. The first step toward this is all external pieces are white to reduce radiation absorption.

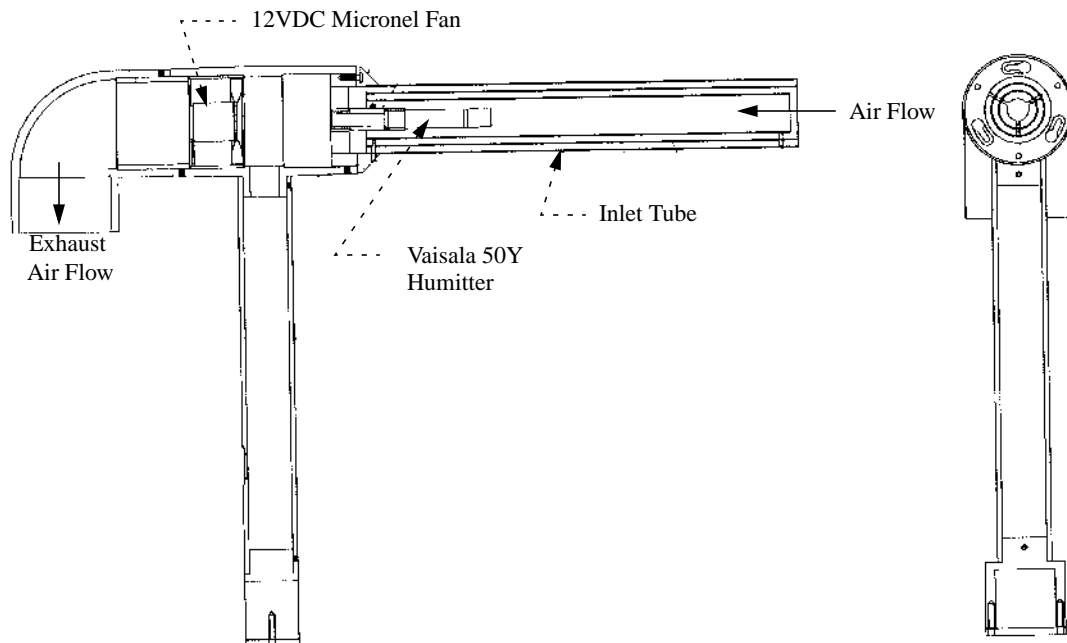

The inlet tube is modeled after the standard Assman design consisting of 2 concentric tubes with the transducers centered in the inner tube. The function of the outer tube is to reduce the effects of direct solar radiation and conductive heat transfre on the transducers. The reduction in direct radiative heating is obtain by painting the inlet white and having the outer tube surrounding the inner tube. In most circumstances this has been very successful. However, in order to obtain a repre-

sentative air sample near the sonic head the instrument is mounted along a horizontal plane. There is the potential for direct and/or reflective radiation getting to the transducers when the sun is at a low angle. Any absorption which conducts to the inner wall of the outer tube is reduced by the fan venting air through the space between the tubes. The inlet tube can be removed without disturbing the 50Y probe.

The fan housing consists of 3 parts: the 50Y mount, the fan mount, and the boom arm attachment. The 50Y mount is located at the front of the fan housing where the inlet tube is attached. The 50Y probe is mounted axially and extends out into the center of the inner inlet tube. The boom arm attachment is located in the center of the fan housing. The attachment has a cavity where the probe and the fan cables are interfaced. The end of the boom arm support has a “U” channel piece which is used to mount the BPH unit to a 1.5” rectangular boom. The fan is mounted at the end of the housing in front of the exhaust tube.

The purpose of the exhaust tube is to provide a minimum resistance path for the air flow, reduce radiation, and prevent any contaminants from flowing back into the fan housing. This is accomplished with a tube having a 90° bend and the same inner diameter as the fan. The advantage of the 90° bend is the outlet of the tube is in a static pressure mode with respect to the horizontal winds, reducing flow resistance and contaminants. A second feature of the exhaust tube is it can be rotated so that the outlet is always pointing toward the ground preventing any sky radiation from entering.

### ***0.3.5 Ventilation Fan:***

The BPH is ventilated with a MICRONEL D589L 12 VDC fan drawing approximately 35ma. Flowrate through the inlet tube has been measured at ~5 m/sec at 0 pressure. The fan is mounted down stream of the sensor so that no heat generated by the fan affects the measurements.

### ***0.3.6 Installation:***

The Bandpass Hygromometer is mounted on the boom arm of the sonic. The intake should be pointing toward the head of the sonic. The user has the freedom to choose how close to the sonic head the intake is mounted. In addition, they can choose to mount the instrument in 4 possible positions going around the boom axis. The normal position is to mount above the boom.

The cable from the instrument should be secured to the boom so no stress is put on the connector. It is recommended to have a “U” shape in the cable going from the instrument to the boom if the instrument is mounted below the boom. This will prevent water flowing from the cable into the connector. The other end of the cable attaches to a special EVE- A/D cable which plugs into the electronics box. Refer to the appendix for cable details.

### ***0.3.7 Calibration:***

The 50Y probe comes from the factory calibrated with a linear fit (refer to section on 50Y probe above). However, with the proper facilities the sensor can be calibrated if one wishes to obtain better accuracies. This is what is done at the NCAR/SSSF sensor calibration lab where individual calibration coefficients can be computed. The appendix contains a sample of a calibration report for a 50Y probe.

**NOTE: The equations presented below are for the user's information. They should be used with caution.**

The transfer function of a platinum resistance device is well documented.

$$T = A_0 + A_1 \times V_{out} + A_2 \times V_{out}^2$$

At SSSF, temperature calibrations take place either in an oil bath using a Standard Platinum Resistance Thermometer, SPRT, probe as a reference or in an environmental chamber using a secondary transfer standard which has been calibrated in the oil bath. Experience has shown an improvement in accuracy to better than  $\pm 0.1^\circ$  C by applying the transfer function above.

The response of a solid-state capacitance transducer, like the 50Y humidity sensor, is not as well documented as a platinum resistance device. Therefore, the user is left to their own on determining a transfer function to convert raw data to calibrated units. Our experience has shown one can improve the overall accuracy of the humidity measurement by a factor of 2 by applying a 1st order polynomial function to the raw data. We have also found a secondary affect due to temperature which adds a cross-product term to the polynomial.

$$RH = B_0 + B_1 \times V_{out} + C_0 \times T \times V_{out}$$

The need for individual calibrations should be determined by the user and always complete a calibration with a spot check test to insure the coefficients are correct!

### **0.3.8 Maintenance:**

The Bandpass Hygrothermometer requires little maintenance. The user may need to clean the capacitance humidity sensor once and awhile depending on the operational environment. This can be done with distilled water and a Q-tip swab. Allow the transducer to dry before operating again.

Dust and debris can degrade the performance and possibly stop the fan. If this happens the inlet and the exhaust tubes can be removed giving access to the fan for replacement.

### **0.3.9 Troubleshooting:**

Monitoring the performance of the BPH is the best way to check for any potential problems. This can be done by doing a side-by-side comparison with a second temperature/humidity system such as a Assman psychrometer or another BPH sensor. Data should be collected for at least 15 minutes, one point every 30 seconds, to insure a good statistical average. There are two sources which may cause bad data, the sensor probe or the fan/ventilation system.

The fan can easily be checked out. Look for potential debris in and around the fan blades and remove. Also look for any debris that may be lodged in the inlet tubes. If the fan has totally stopped running then it must be replaced. Refer to section below on how to replace the fan.

The filter protecting the transducers should be checked. Replace the filter or clean it with distilled water if there is excessive dirt deposited on it. If the temperature data is bad then the 50Y probe must be replaced. The user has the option to replace the humidity transducer without removing the 50Y probe.

**WARNING: If new calibration coefficients are not known for the new transducer or probe then calibrated data may be in error. It is recommended to use the basic linear fit coefficients,  $A_0 = 0$  and  $A_1 = 100$ , if new coefficients do not exist.**

### ***0.3.10 Sensor/Fan replacement:***

The sensor and/or the fan can be replaced. It is recommended the BPH be removed from the station and taken to an indoor environment.

The first step is to remove the exhaust and inlet tubes. The exhaust tube can be removed by loosening the 3 set screws holding the tube to the fan housing. Do not remove the screws since they are small and easy to lose. The inlet tube can be removed by loosening the 3 mounting screws and rotating the tube  $\sim 30^\circ$ . The inner tube is attached to the outer tube so you do not need to remove any screws holding it in place.

The fan can slide out after the exhaust tube is removed. A tool to grab between the fan blades can be used if the fan is stuck. Once out you can unplug the fan from the interface cable.

Once the fan is out you can unplug the 50Y interface cable. The sensor, along with its mo-collar, can be unscrewed.

**NOTE: The mount structure for the 50Y probe consists of 2 pieces, the collar holding the probe and the support mount that the collar screws into. The collar piece must be unscrewed from the support mount. The connector for the 50Y is too large to pass through the hole in the collar piece. If the replacement 50Y probe does not have a collar then you must remove the pins from the connector to remove the probe from the collar.**

Follow the reverse order to re-assemble the Bandpass unit.