

## MICRO DIAPHRAGM GAS PUMPS NMP 830 and NMP 850

Preliminary Sect. 20.42

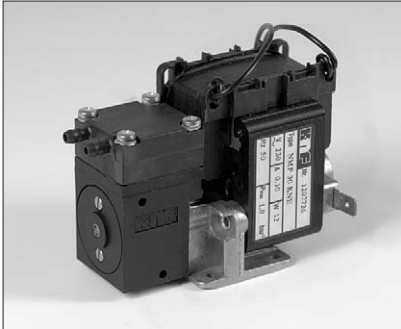

NMP 830 KNI



NMP 830 KNDC B



NMP 850 KNDC

### Concept

The Micro Diaphragm Gas Pumps from KNF are based on a simple principal - an elastic diaphragm, fixed on its edge, moves up and down its central point by means of an eccentric. In this way the gas is transferred using automatic valves.

The new range of KNF Micro Pumps is for the first time equipped with the stress-optimised diaphragm, resulting in a high pneumatic performance, a durable product and compact size. In addition special valves ensure the minimum resistance to flow.

Thanks to the KNF modular system, the parts used to transfer the gases can be made from materials with varying degrees of compatability. The pumps can be driven by either AC motor, DC motors or brushless DC motor for long durability.

### Features

#### Uncontaminated flow

No contamination of the media due to oil-free operation

#### Maintenance-free

#### Compact size

#### High pneumatic performance

#### High level of gas tightness

thanks to the closed diaphragm surface and special sealing system

#### Low aerodynamic loss

by means of a new valve system

#### Long product life

#### Ready for assembly

#### Can operate in any installed position

#### For the version with brushless motor the following also apply:

- safe and reliable constant use
- particularly long durability

### Areas of use

KNF Micro Diaphragm Pumps are used frequently in the fields of analysis and medicine.

For instance as pumps for gas measurement, for example for sampling environmental conditions in the workplace, or for exhaust gas and smoke analysis or built into machines for measuring blood pressure.

The AC models are suited for use in machinery which is permanent or mains-operated. Micro Diaphragm Pumps for portable and stand-alone equipment require DC power supplies.

## PERFORMANCE DATA

Type	Delivery (l/min)	Vacuum (mbar absolute)	atm. Press.	Pressure (bar g)	Weight (g)
NMP 830 KNI	1,8	250		1	590
NMP 830 KNDC B	2,5	240		1,4	270
NMP 830 KNDC	3,1	250		1	195
NMP 850 KNDC B	4,2	230		1,5	360
NMP 850 KNDC	4,5	230		1,5	210

# NMP 830 \_ \_ I

## PERFORMANCE DATA

Type and Order No. <sup>3)</sup>	Delivery at atm. pressure (l/min) <sup>1)</sup>	Max. operating pressure (bar g) <sup>2)</sup>	Ultimate vacuum (mbar abs.)
NMP 830 KNI	1,8	1	250
NMP 830 KVI	1,8	1	250
NMP 830 KTI	1,6	1	310

<sup>1)</sup> Litre at STP <sup>2)</sup> Continuous running

## MOTOR DATA

Protection class	IP 00		
Voltage/Frequencies (V/Hz)	115/60		
Power P <sub>1</sub> (W)	25		

## MODEL CODES AND MATERIALS

Type and Order No. <sup>3)</sup>	Pump head	Diaphragm	Valves
NMP 830 KNI	Ryton <sup>4)</sup> (PPS)	EPDM	Neoprene (CR)
NMP 830 KVI	Ryton <sup>4)</sup> (PPS)	Viton (FPM)	Viton (FPM)
Chemically resistant version			
NMP 830 KTI	Ryton <sup>4)</sup> (PPS)	PTFE coated	FFPM

<sup>3)</sup> See also „MODEL CODES FOR EASY ORDERING“

## Dimensions <sup>5)</sup> (mm)

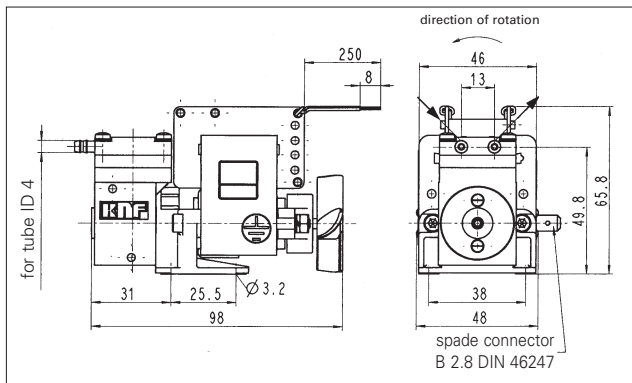

### NMP 830 KNI/NMP 830 KVI

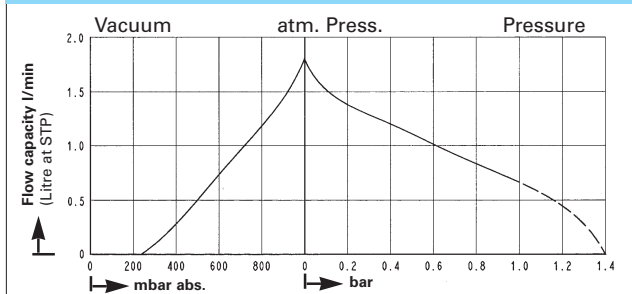

### NMP 830 KTI

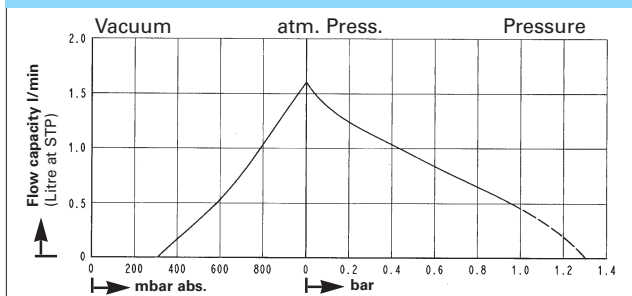

# NMP 830 \_ \_ DC

## PERFORMANCE DATA

Type and Order No. <sup>3)</sup>	DC motor (V)	Delivery at atm. pressure (l/min) <sup>1)</sup>	Max. Operating pressure (bar g) <sup>2)</sup>	Ultimate vacuum (mbar abs.)
NMP 830 KNDC	6	3,1	1	250
NMP 830 KVDC	6	2,7	1	250
NMP 830 KTDC	6	2,6	1	350
NMP 830 KNDC	12	3,1	1	250
NMP 830 KVDC	12	2,7	1	250
NMP 830 KTDC	12	2,6	1	350
NMP 830 KNDC	24	3,1	1	250
NMP 830 KVDC	24	2,7	1	250
NMP 830 KTDC	24	2,6	1	350

<sup>1)</sup> Litre at STP <sup>2)</sup> Continuous running

## MODEL CODES AND MATERIALS

Type and Order No. <sup>3)</sup>	Pump head	Diaphragm	Valves
NMP 830 KNDC	Ryton <sup>4)</sup> (PPS)	EPDM	Neoprene (CR)
NMP 830 KVDC	Ryton <sup>4)</sup> (PPS)	Viton (FPM)	Viton (FPM)
Chemically resistant version			
NMP 830 KTDC	Ryton <sup>4)</sup> (PPS)	PTFE coated	FFPM

<sup>4)</sup> Phillips Petroleum registered trade mark

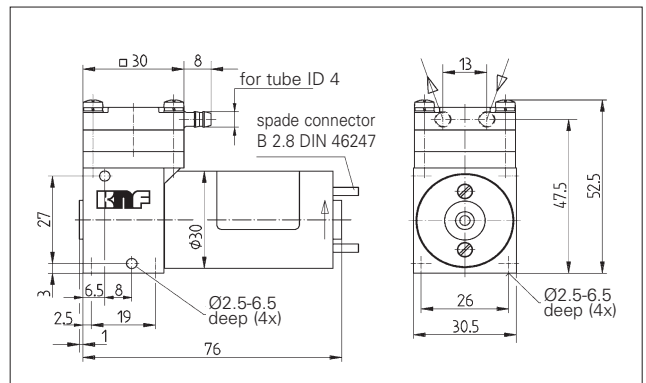

### NMP 830 KNDC

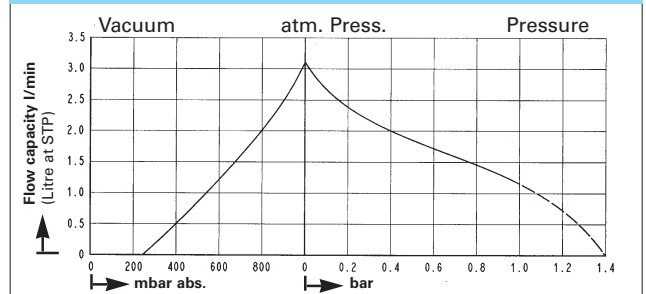

### NMP 830 KVDC

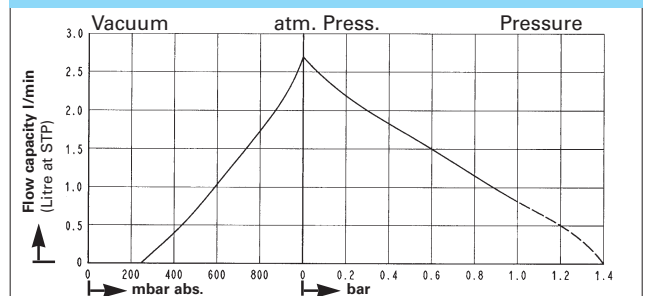

### NMP 830 KTDC

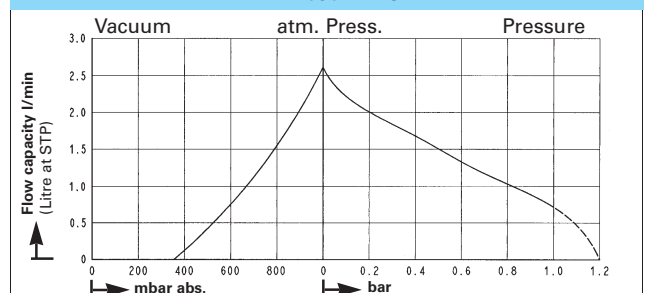

----- for short periods only

<sup>5)</sup> All dimensional tolerances conform to DIN ISO 2768-1, Tolerance Class V

# NMP 830 \_\_ DC B

Version with brushless KNF dc motor

## PERFORMANCE DATA

Type and Order No. <sup>3)</sup>	Brushless dc motor (V)	Delivery at atm. pressure (l/min) <sup>1)</sup>	Max. operating pressure (bar g) <sup>2)</sup>	Ultimate vacuum (mbar abs.)
NMP 830 KNDC B	12	2,5	1,4	240
NMP 830 KVDC B	12	2,1	1,4	240
NMP 830 KTDC B	12	2,1	1,3	330
NMP 830 KNDC B	24	2,5	1,4	240
NMP 830 KVDC B	24	2,1	1,4	240
NMP 830 KTDC B	24	2,1	1,3	330

<sup>1)</sup> Litre at STP <sup>2)</sup> Continuous running

To comply with CE standards (EMC guidelines to EN 55014-1), attention must be paid to the specifications in the operating instruction.

## MODEL CODES AND MATERIALS

Type and Order No. <sup>3)</sup>	Pump head	Diaphragm	Valves
NMP 830 KNDC B	Ryton <sup>4)</sup> (PPS)	EPDM	Neoprene (CR)
NMP 830 KVDC B	Ryton <sup>4)</sup> (PPS)	Viton (FPM)	Viton (FPM)
Chemically resistant version			
NMP 830 KTDC B	Ryton <sup>4)</sup> (PPS)	PTFE coated	FFPM

<sup>4)</sup> Phillips Petroleum registered trade mark

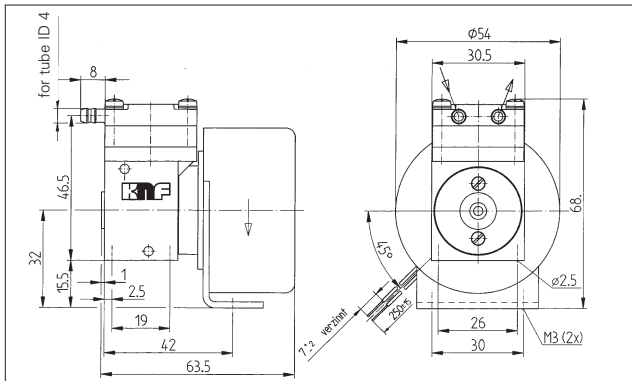

NMP 830 KNDC B

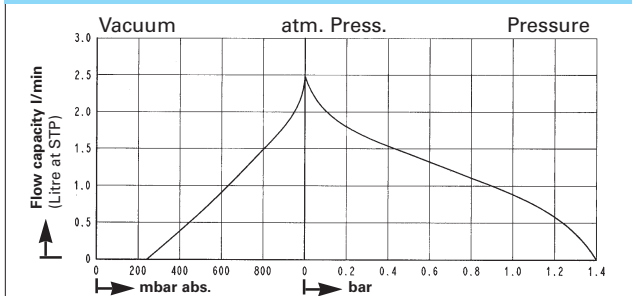

NMP 830 KVDC B

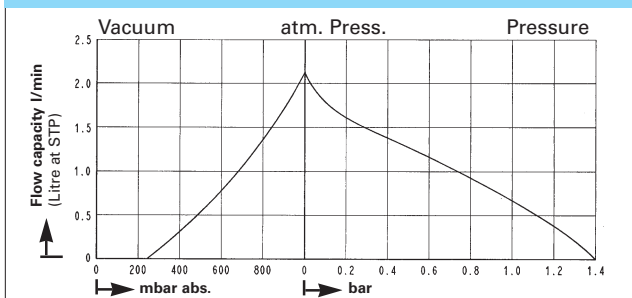

NMP 830 KTDC B

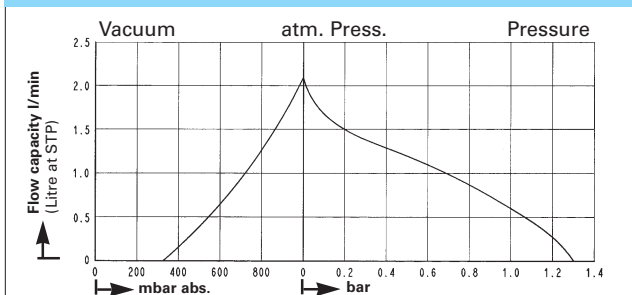

# NMP 850 \_\_ DC

## PERFORMANCE DATA

Type and Order No. <sup>3)</sup>	Brushless dc motor (V)	Delivery at atm. pressure (l/min) <sup>1)</sup>	Max. operating pressure (bar g) <sup>2)</sup>	Ultimate vacuum (mbar abs.)
NMP 850 KNDC	12	4,5	1,5	230
NMP 850 KTDC	12	3,9	1,5	300
NMP 850 KNDC	24	4,5	1,5	230
NMP 850 KTDC	24	3,9	1,5	300

<sup>1)</sup> Litre at STP <sup>2)</sup> Continuous running

## MODEL CODES AND MATERIALS

Type and Order No. <sup>3)</sup>	Pump head	Diaphragm	Valves
NMP 850 KNDC B	Ryton <sup>4)</sup> (PPS)	EPDM	EPDM
Chemically resistant version			
NMP 850 KTDC B	Ryton <sup>4)</sup> (PPS)	PTFE coated	FFPM

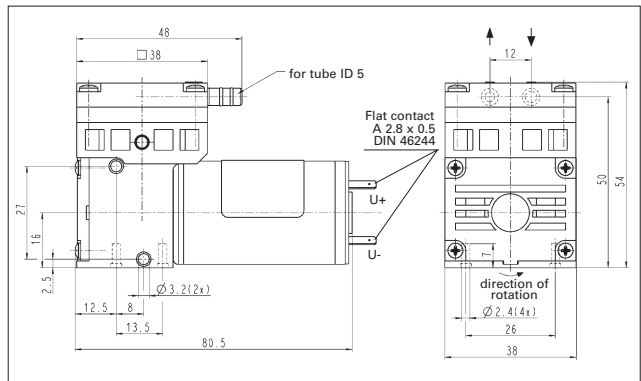

NMP 850 KNDC

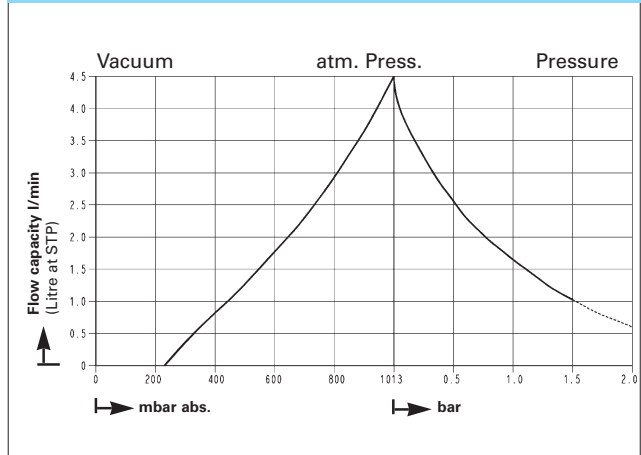

NMP 850 KTDC

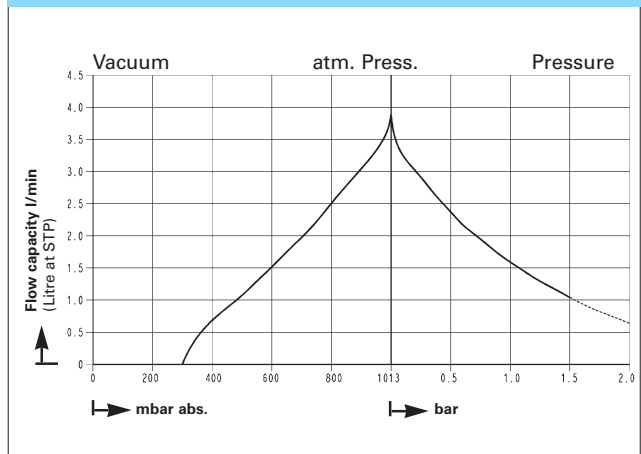

# NMP 850 \_ \_ DC B

Version with brushless KNF dc motor

## PERFORMANCE DATA

Type and Order No. <sup>3)</sup>	Brushless dc motor (V)	Delivery at atm. pressure (l/min) <sup>1)</sup>	Max. operating pressure (bar g) <sup>2)</sup>	Ultimate vacuum (mbar abs.)
NMP 850 KNDC B	12	4,2	1,5	230
NMP 850 KTDC B	12	3,5	1,5	300
NMP 850 KNDC B	24	4,2	1,5	230
NMP 850 KTDC B	24	3,5	1,5	300

<sup>1)</sup> Litre at STP <sup>2)</sup> Continuous running

To comply with CE standards (EMC guidelines to EN 55014-1), attention must be paid to the specifications in the operating instruction.

## MODEL CODES AND MATERIALS

Type and Order No. <sup>3)</sup>	Pump head	Diaphragm	Valves
NMP 850 KNDC B	Ryton <sup>4)</sup> (PPS)	EPDM	EPDM
Chemically resistant version			
NMP 850 KTDC B	Ryton <sup>4)</sup> (PPS)	PTFE coated	FFPM

<sup>4)</sup> Phillips Petroleum registered trade mark

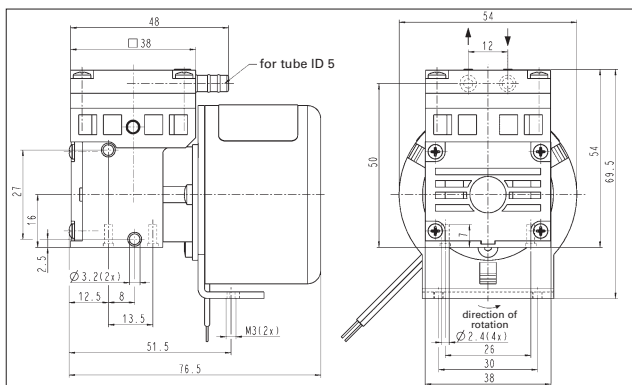

### NMP 850 KNDC B

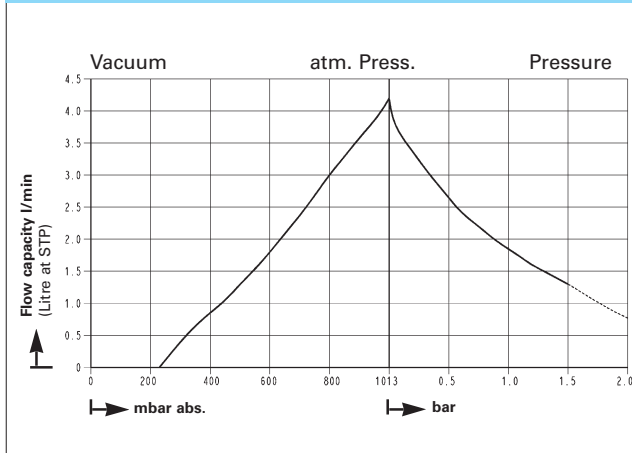

### NMP 850 KTDC B

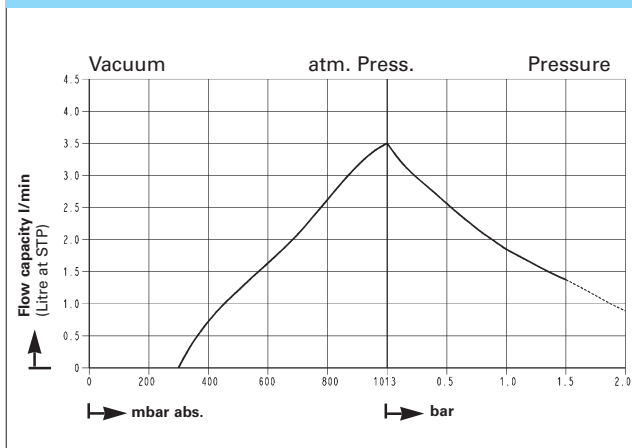

## HINTS ON FUNCTION, INSTALLATION AND SERVICE

### FUNCTION OF KNF DIAPHRAGM VACUUM PUMPS AND COMPRESSORS

An elastic diaphragm is moved up and down by an eccentric (see illustration). On the down-stroke it draws the air or gas being handled through the inlet valve. On the up-stroke the diaphragm forces the medium through the exhaust valve and out of the head. The compression chamber is hermetically separated from the drive mechanism by the diaphragm. The pumps transfer, evacuate and compress completely oil-free.

#### Diaphragm pump

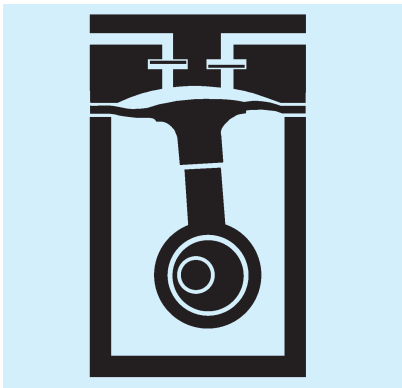

### HINTS ON INSTALLATION AND OPERATION

- Range of use: Transferring air and gases at temperatures between +5°C and +40°C
- Use chemically resistant version for aggressive gases and vapours
- Permissible ambient temperature: between +5°C and +40°C
- The standard pumps are not suitable for use in areas where there is a risk of explosion. In these cases there are other products in the KNF program - please ask us for details
- The pumps are not designed to start against pressure or vacuum; when a pump is switched on the pressure in the suction and pressure lines must be atmospheric. Pumps that start against pressure or vacuum are available on request
- To prevent the maximum operating pressure being exceeded, restriction or regulation of the air flow should only be carried out in the suction line

- Components connected to the pump must be designed to withstand the pneumatic performance of the pump
- Install the pump so that the fan can draw in sufficient cooling air
- Fit the pump at the highest point in the system, so that condensate cannot collect in the head of the pump - that prolongs working-life.

### TECHNICAL DETAILS

Motors with other voltages and frequencies on request.

### HINTS ON SERVICE

The diaphragm and valve plates are the only parts of the KNF diaphragm pumps subject to wear. They are easy to change, as no special tools are needed.

If you have any questions, please call our application engineers (see below for contact telephone number).

### MODEL CODE FOR EASY ORDERING

The model code is identical to the order number. It is made up as follows, (sample):

<b>N 830</b>	<b>KN</b>	<b>I or DC</b>	<b>120 V/60 Hz, IP 00 or 12 V</b>
--------------	-----------	----------------	-----------------------------------

- Base model
- Head materials
- OEM Version with ac (I) or dc motor (DC)
- Other motor data eg.:

In addition the motor data must be given in the purchase order (voltage, frequency, and protection class). In our extensive program you are sure to find the pump you need for your particular application.

## ACCESSORIES

Description	Details	Order No.
Filter/silencer	for NMP 830	024805

### KNF Neuberger, Inc.

2 Black Forest Road  
Trenton, NJ 08691-1810  
Tel. 609-890-8600  
Fax 609-890-8323  
[www.knf.com/usa.htm](http://www.knf.com/usa.htm)